

600 SERIES LATERAL AND SHELF FILE LABEL HOLDER

INSTALLATION INSTRUCTIONS

Illustration 1

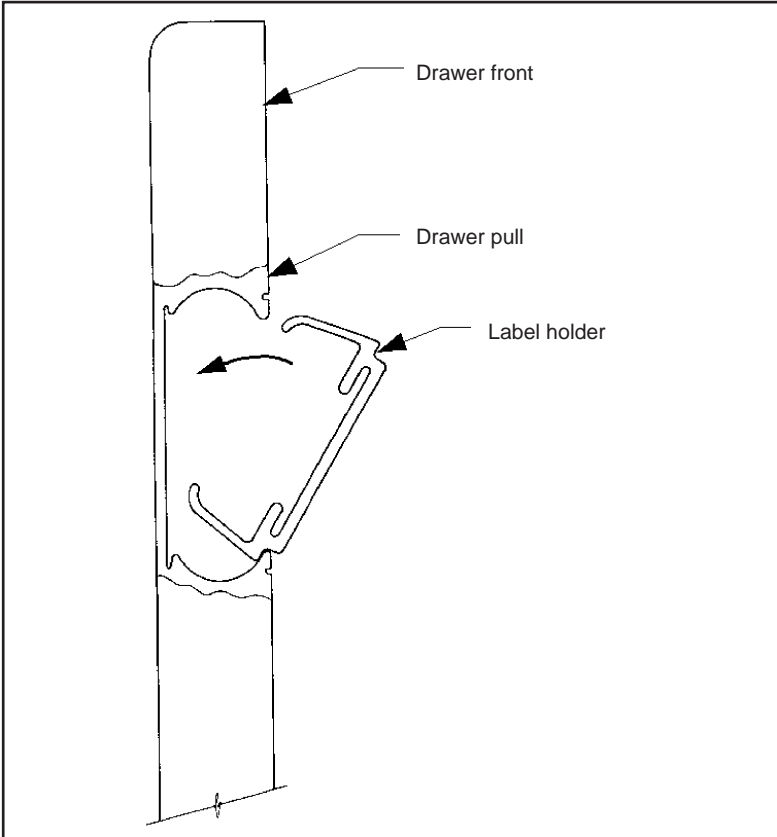

Read all instructions and review illustrations before installing.

Tools required for assembly:
None

This assembly includes:
Label holder
Label

Installation:

1. Refer to Illustration 1. Place bottom lip of label holder onto bottom edge of drawer pull.
2. Refer to Illustration 1. While applying downward pressure to top of label holder, push inward until label holder snaps into place.

NOTE

To allow access to the drawer pull, the label holder must be positioned to either side of drawer pull.

3. Slide label holder either to the left or right side of drawer pull.
4. Refer to Illustration 2. Insert label into label holder by sliding label into label holder grooves.

Illustration 2

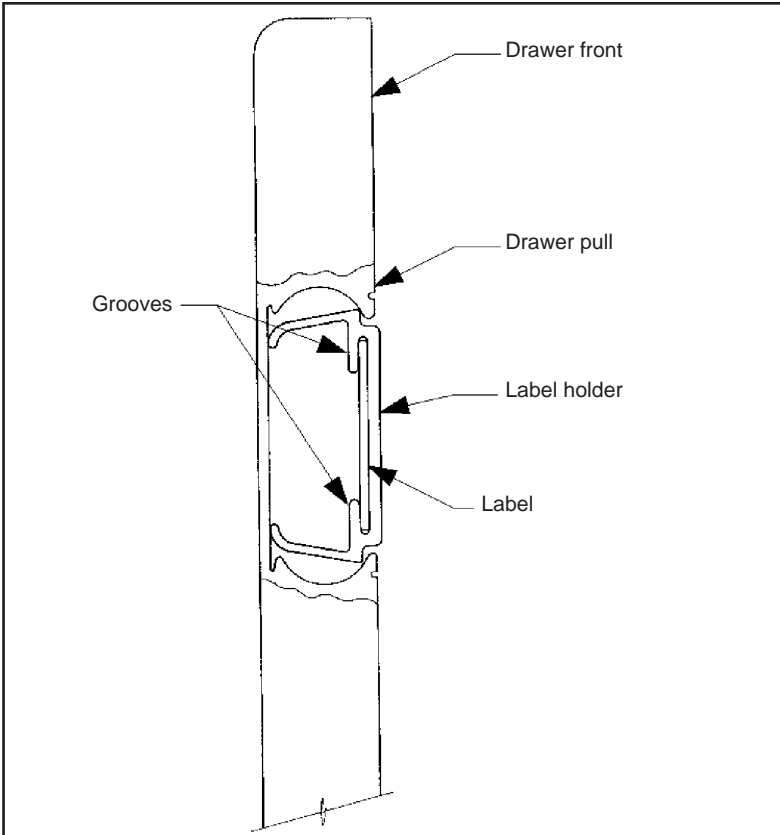

INSTALLATION AND USE MANUAL FOR SHELF FILES

Please retain this manual for later use.

! WARNING

AN IMPROPERLY INSTALLED SHELF FILE CAN BECOME UNSTABLE OR TIP OVER, CAUSING SERIOUS INJURY. FOLLOW ALL INSTRUCTIONS IN THIS MANUAL FOR CORRECT INSTALLATION, USE, AND MAINTENANCE.

These files are for storing and filing noncombustible materials that do not require special protection. Do not use this cabinet to store combustible or hazardous materials.

LEVELING

Tools required for leveling file:

- | | |
|---------------------------------------|---------------------------------------|
| 1/4" Drive socket wrench | 24" long level |
| 1/4" Drive extension | Straight blade screwdriver (optional) |
| 1/4" Six-point socket with 1/4" drive | |

Four leveling glides are provided. Glide adjustment is critical for cabinet stability and proper operation.

1. Be sure cabinet is empty.
2. Position cabinet into desired location.
3. If cabinet has optional adjustable shelves, remove bottom shelf. Level cabinet by using a 1/4" socket or straight blade screwdriver.
4. Turn glides clockwise to raise cabinet. Turn counterclockwise to lower cabinet.
5. On carpeted floors, extend all four glides until the weight of the cabinet is supported by the glides (not by the cabinet bottom).
6. Level cabinet side-to-side.
7. On carpet, adjust glides so the front of the cabinet is 1/4" higher than the rear. On uncarpeted floors, the front should be 1/8" higher than the rear.

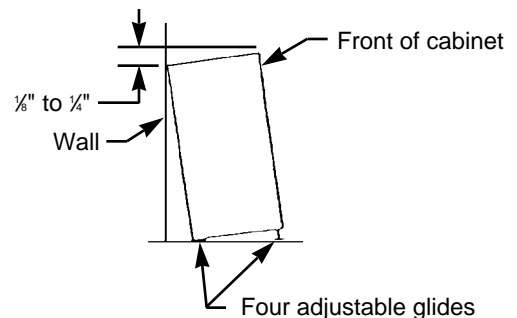
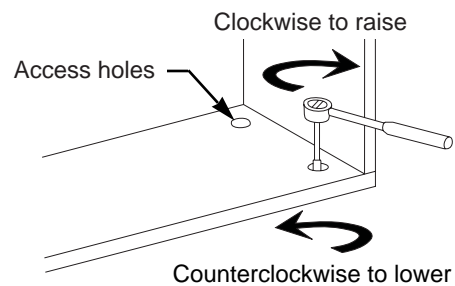

INSTALLATION AND ANCHORING

To increase stability and avoid tipover, cabinets should be bolted together or anchored to a wall whenever possible.

1. Level all units to be connected or anchored.
2. Remove knockout(s).
3. Use the hardware provided in the coin envelope to bolt cabinets together.
4. Use wall anchoring devices when securing a cabinet to a wall. Be sure to use the right devices for the type of wall you have.

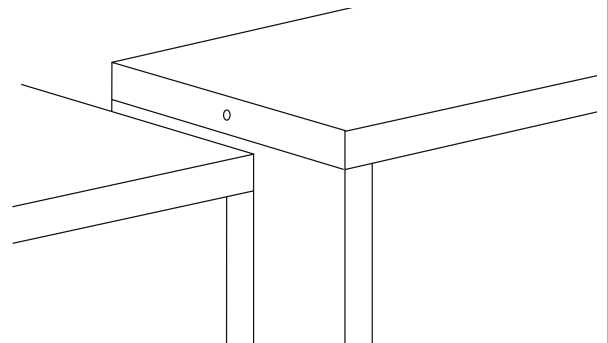

LOADING AND UNLOADING

WARNING

An improperly loaded or unloaded file cabinet can become unstable or tip over, causing serious injury.

Loading:

1. Check cabinet for proper leveling and stability.
2. Load bottom drawer first to increase stability.
3. Distribute contents and weight evenly among remaining shelves.
4. Check to see if cabinet is stable after loading is complete. If necessary, empty cabinet completely, then readjust glides.

Unloading:

1. Remove contents from top shelf first.
2. Remove contents from bottom shelf last.

RELOCATING

WARNING

If not properly secured when moving, this shelf file can become unstable or tip over, causing serious injury.

Before moving cabinet:

1. Unload contents. (Unload from the top. See loading and unloading above.)
2. Secure the unit:
 - Use furniture straps and appropriate moving equipment.
3. After positioning cabinet in new location, follow instructions for leveling and installing.

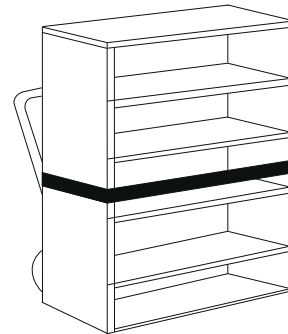

DIVIDER OPERATION

1. Squeeze sides of divider and align bottom ends (U-shaped flanges) of divider with cut outs in shelf.
2. Insert U-shaped flanges into cut-outs in shelf.
3. Slide divider toward side wall of cabinet, inserting edge of shelf cut-outs into divider U-shaped flanges.
4. Release tension on sides of divider to lock divider in place.
5. Reverse procedure to remove divider.

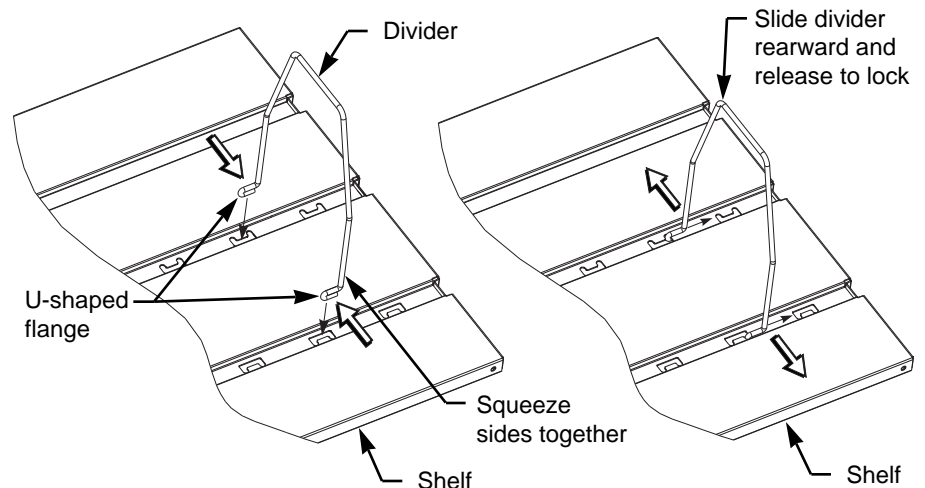

OPTIONAL ADJUSTABLE SHELF INSTALLATION

1. Place shelf brackets at desired height location and inset lance tabs into holes provided in each case side member.
2. Ensure shelf brackets installed across from each other are installed at the same height.
3. Slide shelf into cabinet until slot on bottom edge of shelf side lowers onto tabs of each shelf bracket.

