

INSTALLATION AND USE MANUAL FOR LATERAL FILES

Please return this manual to the orange storage pocket in the bottom drawer.

WARNING

AN IMPROPERLY INSTALLED FILE CABINET CAN BECOME UNSTABLE OR TIP OVER, CAUSING SERIOUS INJURY. FOLLOW ALL INSTRUCTIONS IN THIS MANUAL FOR CORRECT INSTALLATION, USE, AND MAINTENANCE.

These files are for storing and filing non-combustible materials that do not require special protection. Do not use this cabinet to store combustible or hazardous materials.

REQUIRED ADJUSTMENT

Tools required for adjusting file:

24" long level

Four leveling glides are provided. Glide adjustment is critical for cabinet stability and proper operation of lock and interlock.

1. Be sure cabinet is empty.
2. Position cabinet into desired location.
3. To access glides, have an assistant tip cabinet backward slightly and hold. Adjust cabinet by turning glides with your hand.
4. Turn glides counter-clockwise to raise cabinet. Turn clockwise to lower cabinet.
5. On carpeted floors, extend glides until the weight of the cabinet is supported by the glides (not by the cabinet bottom).
6. Level cabinet side-to-side.
7. On carpet, adjust glides so the front of the cabinet is $\frac{1}{4}$ " higher than the rear. On uncarpeted floors, the front should be $\frac{1}{8}$ " higher than the rear.
8. Check cabinet for proper operation. Drawers and doors should open and close smoothly and be evenly aligned with the frame.

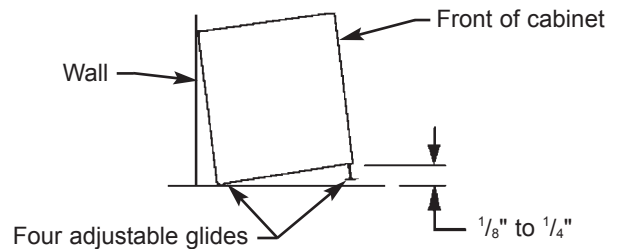
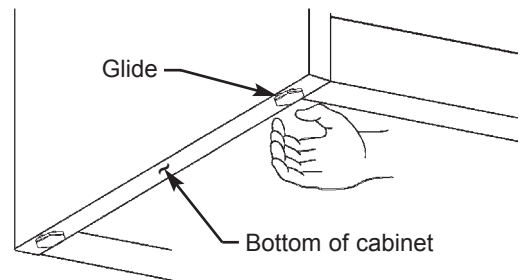

LOADING AND UNLOADING

WARNING

An improperly loaded or unloaded file cabinet can become unstable or tip over, causing serious injury.

Loading:

1. Check cabinet for proper adjustment and stability.
2. Load bottom drawer first to increase stability.
3. Distribute contents and weight evenly among remaining drawers.
4. Check to see if cabinet is stable after loading is complete. If necessary, empty cabinet completely, then readjust glides.

Unloading:

1. Remove contents from top drawer first.
2. Remove contents from bottom drawer last.

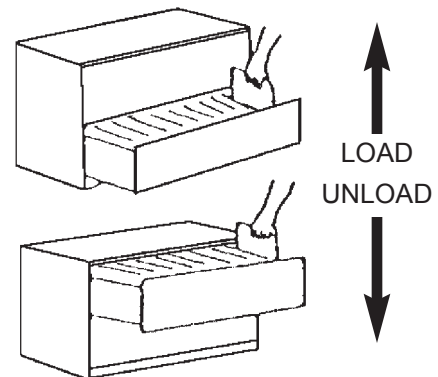

OPERATING



WARNING

If misused, this file cabinet can become unstable or tip over, causing serious injury. To help prevent accidents, follow the instructions below.

- Do not stand or lean on an open drawer.
- Do not put materials on an open drawer. Use a separate table to sort or collate.
- If this cabinet ever seems unstable, do not use it. Have it checked for proper adjustment and loading. Have any problems corrected immediately.
- This cabinet has an interlock to prevent opening more than one drawer at a time. Do not try to defeat this interlock.
- These files are for storing and filing non-combustible materials that do not require special protection. Do not use this cabinet to store combustible or hazardous materials.

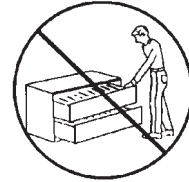

RELOCATING



WARNING

If not properly secured when moving, this file cabinet can become unstable or tip over causing serious injury.

Before moving cabinet:

1. Unload contents. (Unload from the top. See loading and unloading.)
2. Secure the unit:
 - Close and lock the cabinet.
 - Use furniture straps and appropriate moving equipment.
3. After positioning cabinet in new location, follow instructions for adjustment.

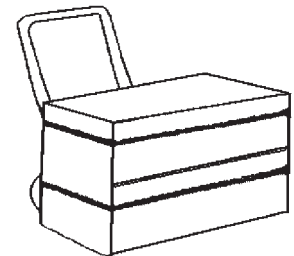

HANGRAILS

1. Install front-to-rear hangrails onto top of drawer sides.
2. Locate and snap a hangrail clip onto each hangrail directly behind drawer front.
3. Insert a hanging folder support into front clips with angled leg toward drawer front.
4. Determine folder width and assemble rear hangrail clips at the desired location.
5. Insert a hanging folder support into rear clips with angled leg toward drawer back.
6. If front-to-back filing is desired, (not applicable on model 11638) place the crossfile sliding hangrails over the hanging folder supports.

