

# 105720RD RECEPTION STATION

# INSTALLATION INSTRUCTIONS

Illustration 1

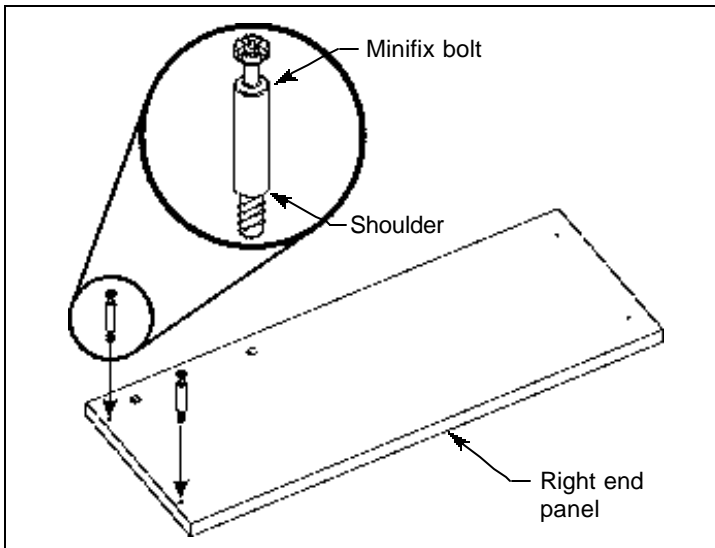

Illustration 2

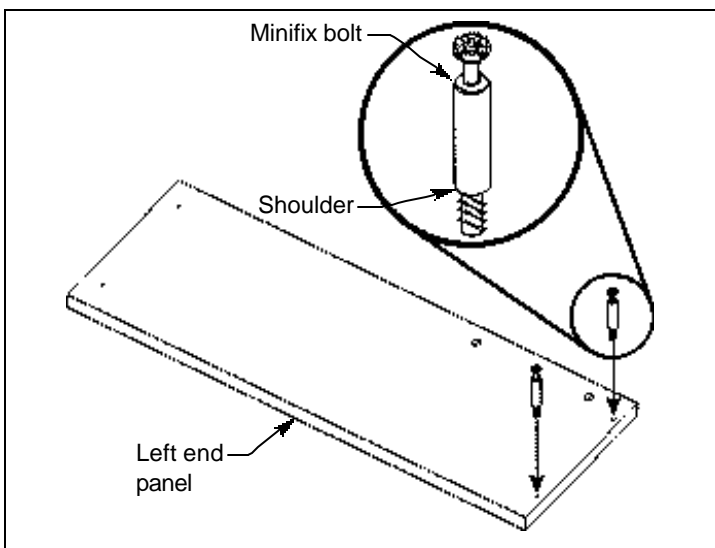
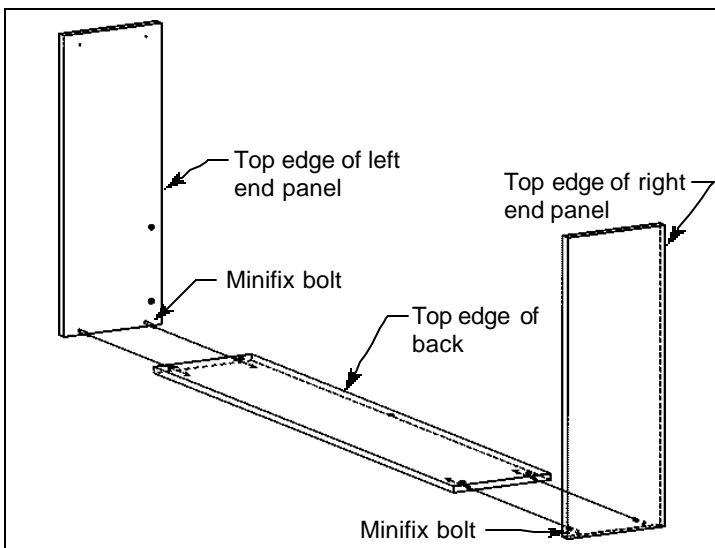

Illustration 3



Read all instructions and review illustrations before installing.

Tools required for assembly:  
Phillips screwdriver                      Rubber mallet  
Scissors

This assembly includes:  
(1) Top    (9) Minifix bolt  
(1) Right end panel                          (9) Minifix cam  
(1) Left end panel                            (4) Dowel  
(1) Back    (2) Reveal  
(-) Mounting tape

## WARNING

Wood products are heavier than they appear and may be hard to control when moving. Use two or more people when moving wood products or severe personal injury may result. Heavy panels can pinch or crush fingers. Do not place fingers between or under panels during assembly.

### Assembly:

1. Refer to Illustration 1. Lay right end panel, with holes up, on cardboard or a carpeted surface. Use the Phillips screwdriver to install two minifix bolts (from hardware pack) onto right end panel. Tighten each minifix bolt until minifix bolt shoulder is flat against surface of right end panel.
2. Refer to Illustration 2. Lay left end panel, with holes up, on cardboard or a carpeted surface. Use the Phillips screwdriver to install two minifix bolts (from hardware pack) onto left end panel. Tighten each minifix bolt until minifix bolt shoulder is flat against surface of left end panel.
3. Refer to Illustration 3. Attach end panels to back by inserting minifix bolts, attached to end panels, into holes drilled into sides of back. Ensure holes in top edge of end panels and back are facing up.

# 105720RD RECEPTION STATION

Illustration 4

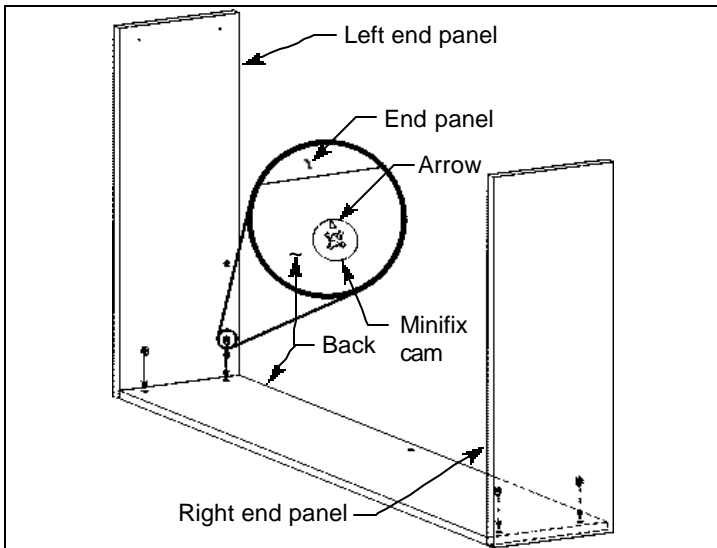

4. Refer to Illustration 4. With arrows facing end panels, install four minifix cams (from hardware pack) into holes along sides of back.

Use the Phillips screwdriver to tighten minifix cams. Turn minifix cams clockwise to tighten.

Illustration 5

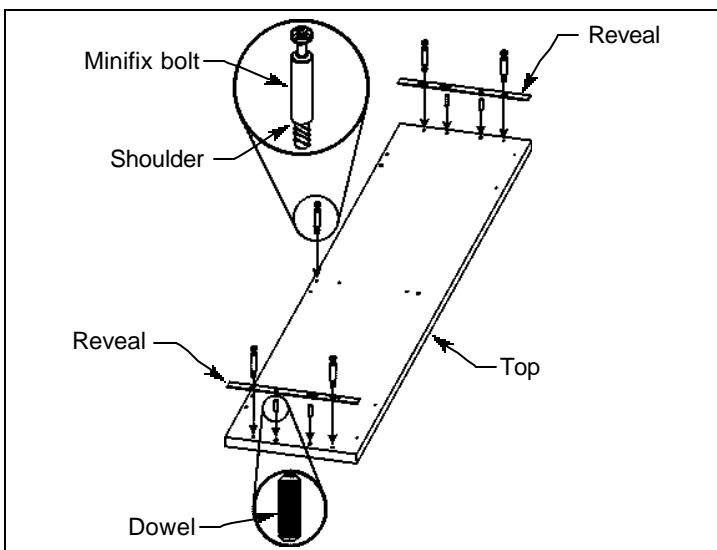

5. Refer to Illustration 5. Lay top, with holes up, on cardboard or a carpeted surface.

Use the rubber mallet to install four dowels (from hardware pack) into large holes along each side of top.

Place reveals onto top (over dowels) as shown. Align holes in reveals with holes along sides of top. Position reveals so that edge of each reveal is flush with edge of top.

Use the Phillips screwdriver to install five minifix bolts (from hardware pack) onto top at the locations shown. Tighten each minifix bolt until minifix bolt shoulder is flush against surface of top.

Illustration 6

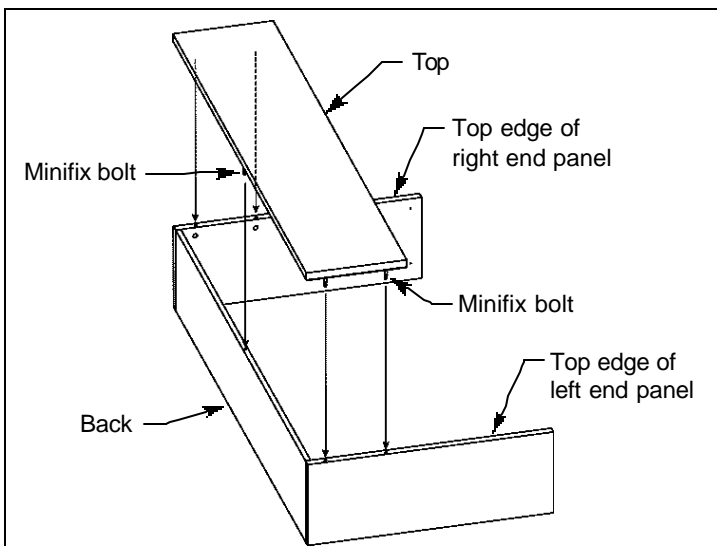

6. Refer to Illustration 6. Attach top to base assembly by inserting minifix bolts, attached to top, into holes drilled into top edges of back and end panels.

# 105720RD RECEPTION STATION

Illustration 7

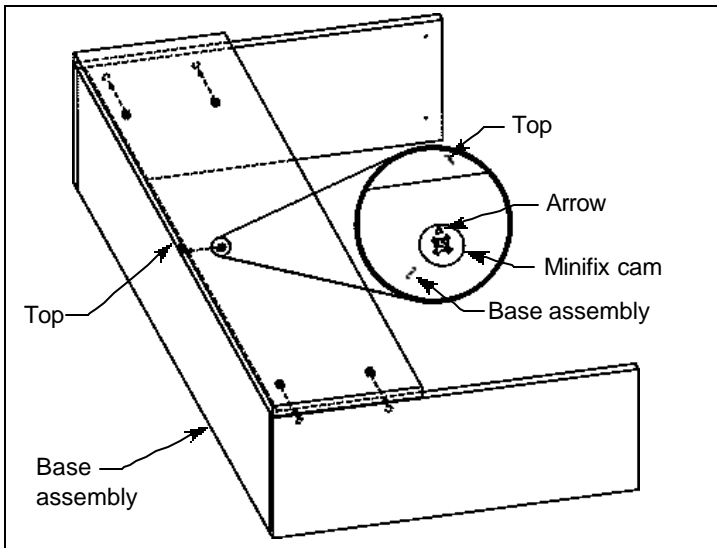

7. Refer to Illustration 7. With arrows facing top, install five minifix cams (from hardware pack) into holes along top edge of base assembly.

Use the Phillips screwdriver to tighten minifix cams. Turn minifix cams clockwise to tighten.

Illustration 8

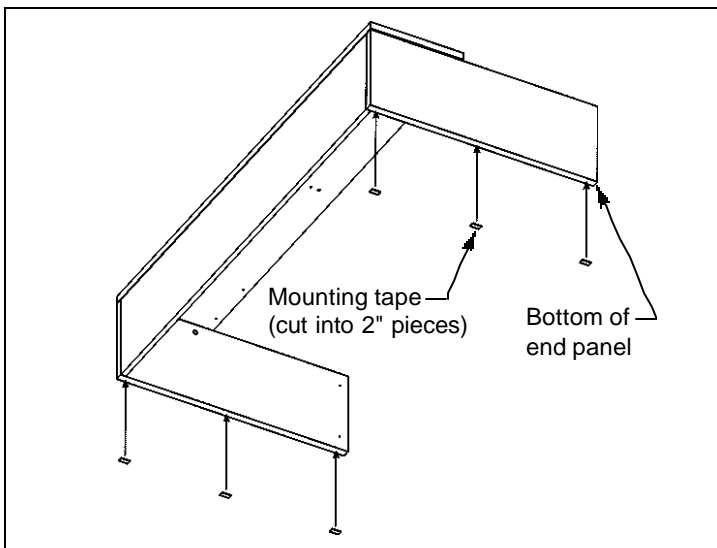

## IMPORTANT

Mounting tape used to secure reception station is extremely sensitive and designed for permanent installation. Attempting to remove mounting tape after installation will damage mounting tape.

8. Refer to Illustration 8. Ensure bottoms of reception station end panels are clean, dry, and free of oils. Use a rag and warm soapy water to clean bottom of end panels.

Unroll mounting tape and cut tape into six 2" pieces. Carefully apply mounting tape to bottoms of reception station end panels as shown.

Illustration 9

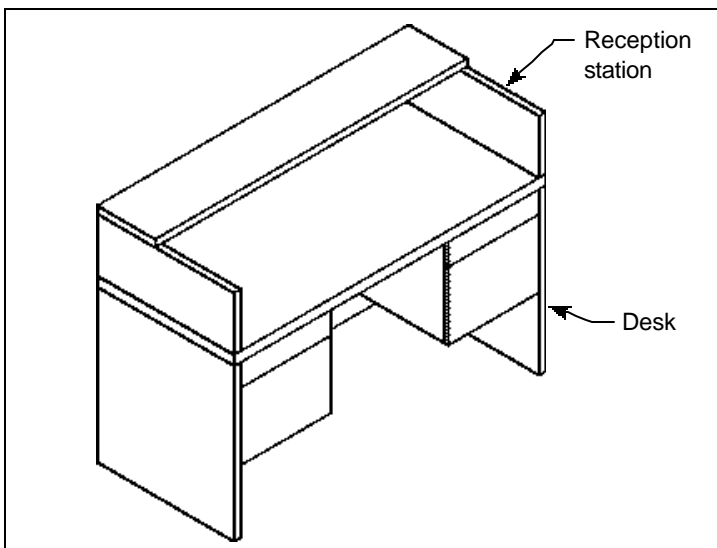

## Reception Station Installation:

1. Ensure top of desk is clean, dry, and free of oils.

## IMPORTANT

Do not remove protective cover on mounting tape until instructed to do so.

2. Refer to Illustration 9. Use two or more people to position reception station onto desk. reception station should be centered from side-to-side and flush with rear edge of desk. **Do not remove protective cover from mounting tape on bottom edge of end panels.** After aligning reception station, place masking tape on top of desk to mark position.

# 105720RD RECEPTION STATION

Illustration 10

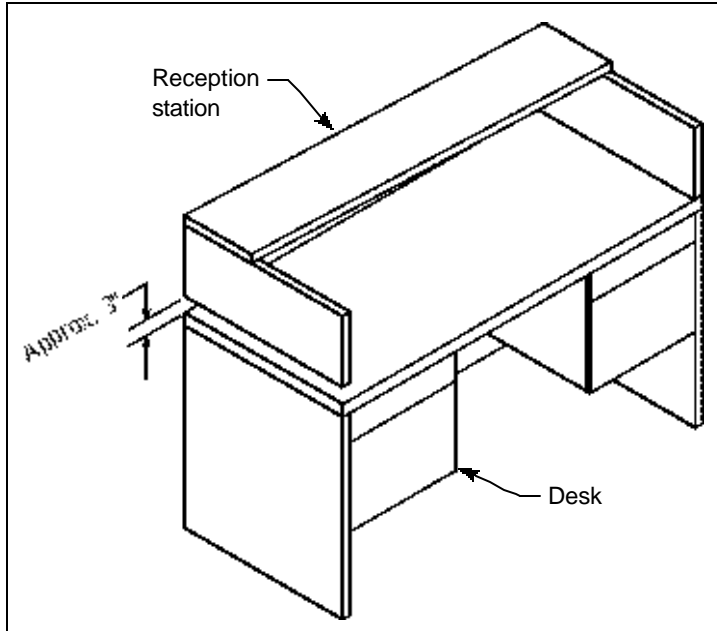

## IMPORTANT

Mounting tape used to secure reception station is extremely sensitive and designed for permanent installation. Attempting to remove reception station will cause severe damage to surface of desk.

3. Refer to Illustration 10. Lift one end of reception station up approximately 3". Take care not to apply any pressure which may cause the opposite end of the reception station to slip off of the desk.

While reception station is raised, remove protective cover from mounting tape. While maintaining alignment, carefully lower reception station and realign end panel with masking tape.

Repeat this procedure for opposite end of reception station.

## WARNING

**Do not lean on, bump, or load shelf of this reception station for a period of 12 hours minimum after mounting tape has been in contact with desk. Do not use this reception station without the mounting tape. Failure to follow this warning can cause the reception station to tip and fall, resulting in severe injury to yourself or others.**