

88598788 Bar Stool with Metal Stretcher Bar (Coffee Finish)

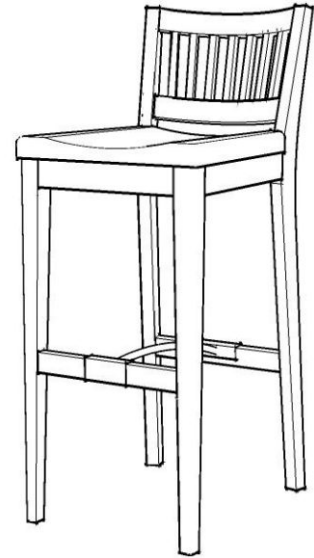

Thai Patent Pending Numbers 108356

IMPORTANT NOTE

Carefully remove all the parts from the carton and put them individually on a soft cloth to prevent scratches or other damages occurring to the wood parts.

We have taken great care in the design of this product and request that you carefully and strictly follow our assembly instructions to ensure a completed product as it was designed.



Casual Attire For Today's Home

PART LIST

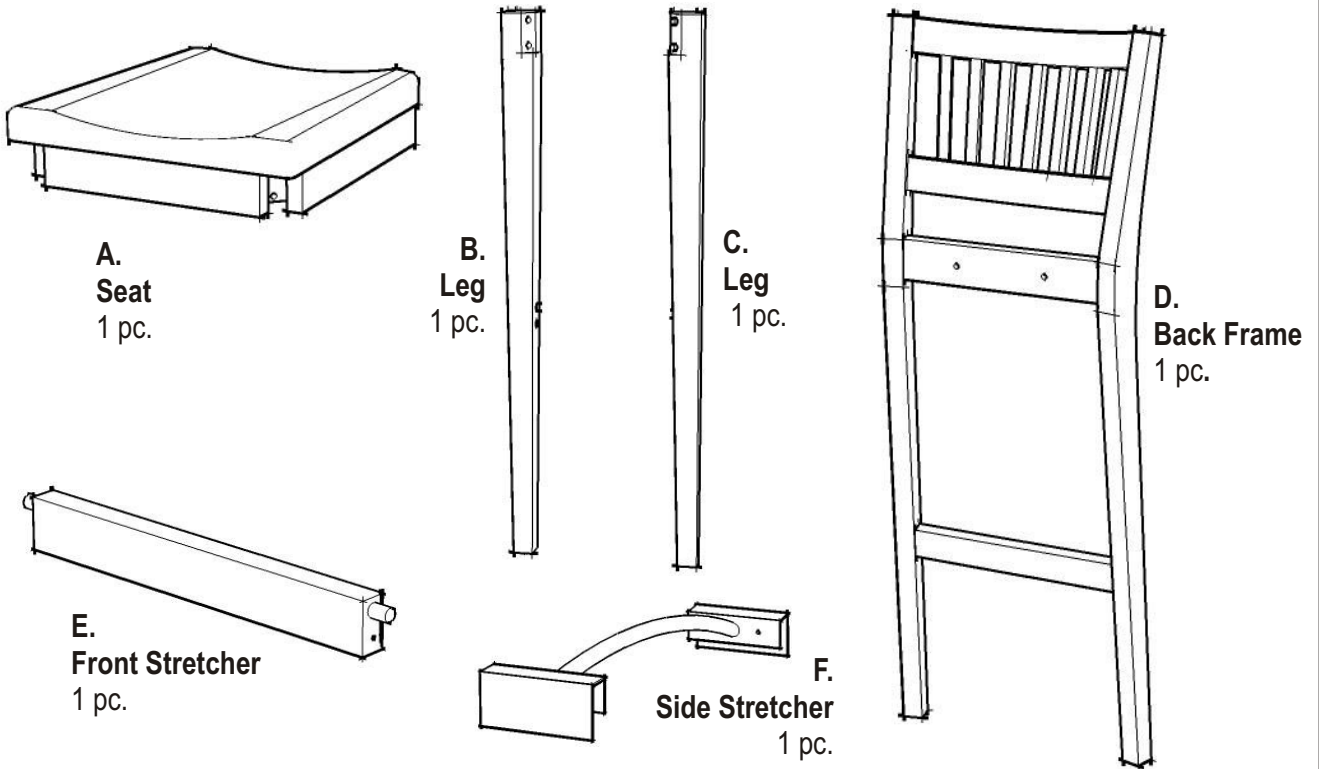

HARDWARE LIST

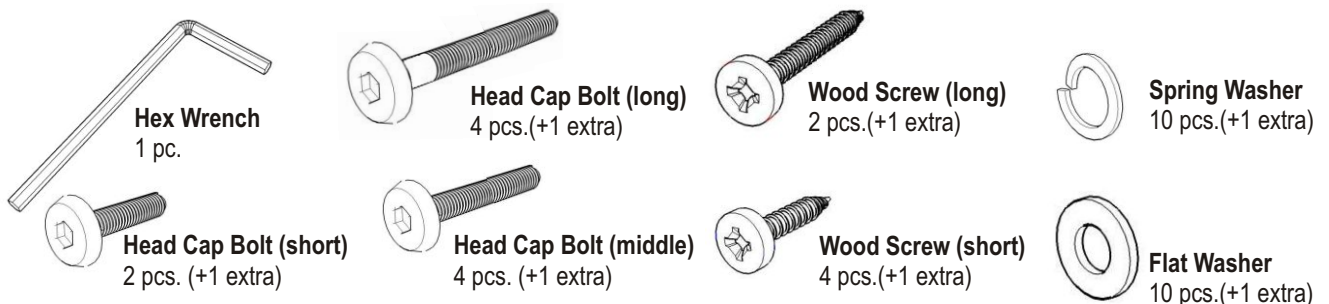

Tools Required For Assembly : Philips screwdriver

Assembly Instructions

IMPORTANT

- * Do not tighten up all the screws until each part is properly assembled.
- * You should keep Hex Wrench in the safe place as you may need to tighten up the Head Cap Bolts in the future.

STEP 1

Turn Seat (A) upside down and place it on a soft cloth.

Attach Leg (B) and (C) to Seat (A), using Head Cap Bolts, Spring Washers and Flat Washers. (See figure 1)

Tighten Head Cap Bolts only half way.

Attach Front Stretcher (E) in between Leg (B) and (C) with Wood Screws. (See figure 2)

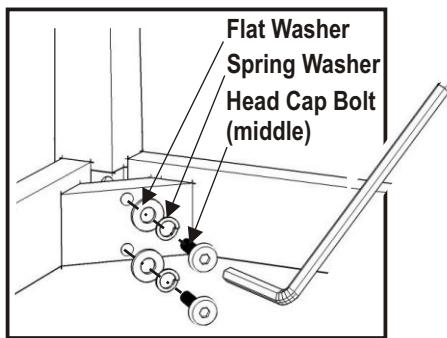

(Figure 1)

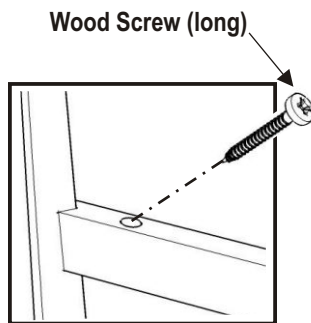

(Figure 2)

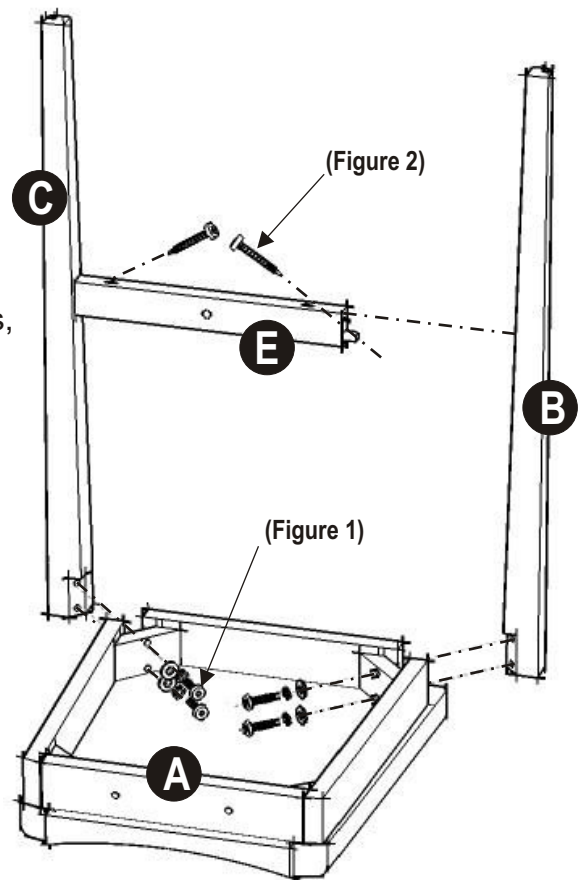

STEP 2

Attach Back Frame (D) to the unit, using Head Cap Bolts, Spring Washers and Flat Washers. (See figure 3-4)

Attach Side Stretcher (F) to the unit with Wood Screws.

Tighten up all Head Cap Bolts.

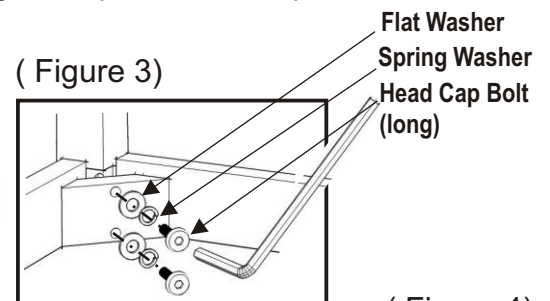
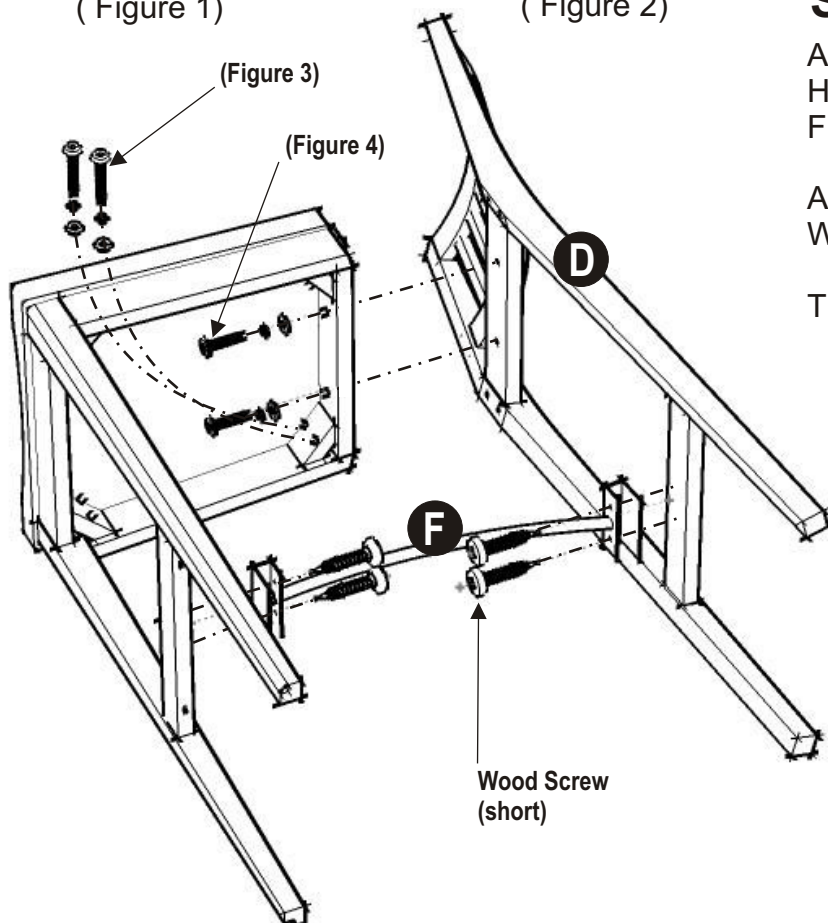

(Figure 4)

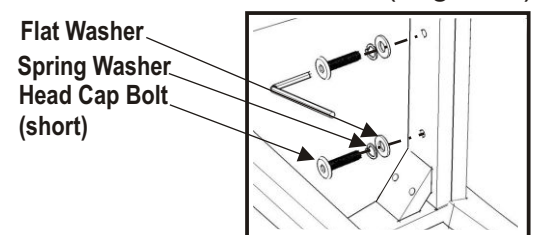

Flat Washer
Spring Washer
Head Cap Bolt
(short)