

# 88 5181 93

## Arts & Crafts

### Expand-a-Desk

#### IMPORTANT NOTE

Carefully remove all the parts from the carton and put them individually on a soft cloth to prevent scratches or other damages occurring to the wood parts.

We have taken great care in the design of this product and request that you carefully and strictly follow our assembly instructions to ensure a completed product as it was designed.

*Home Styles*

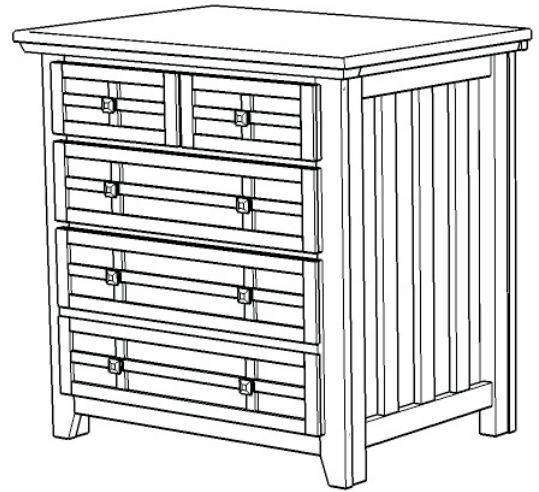

## Part List

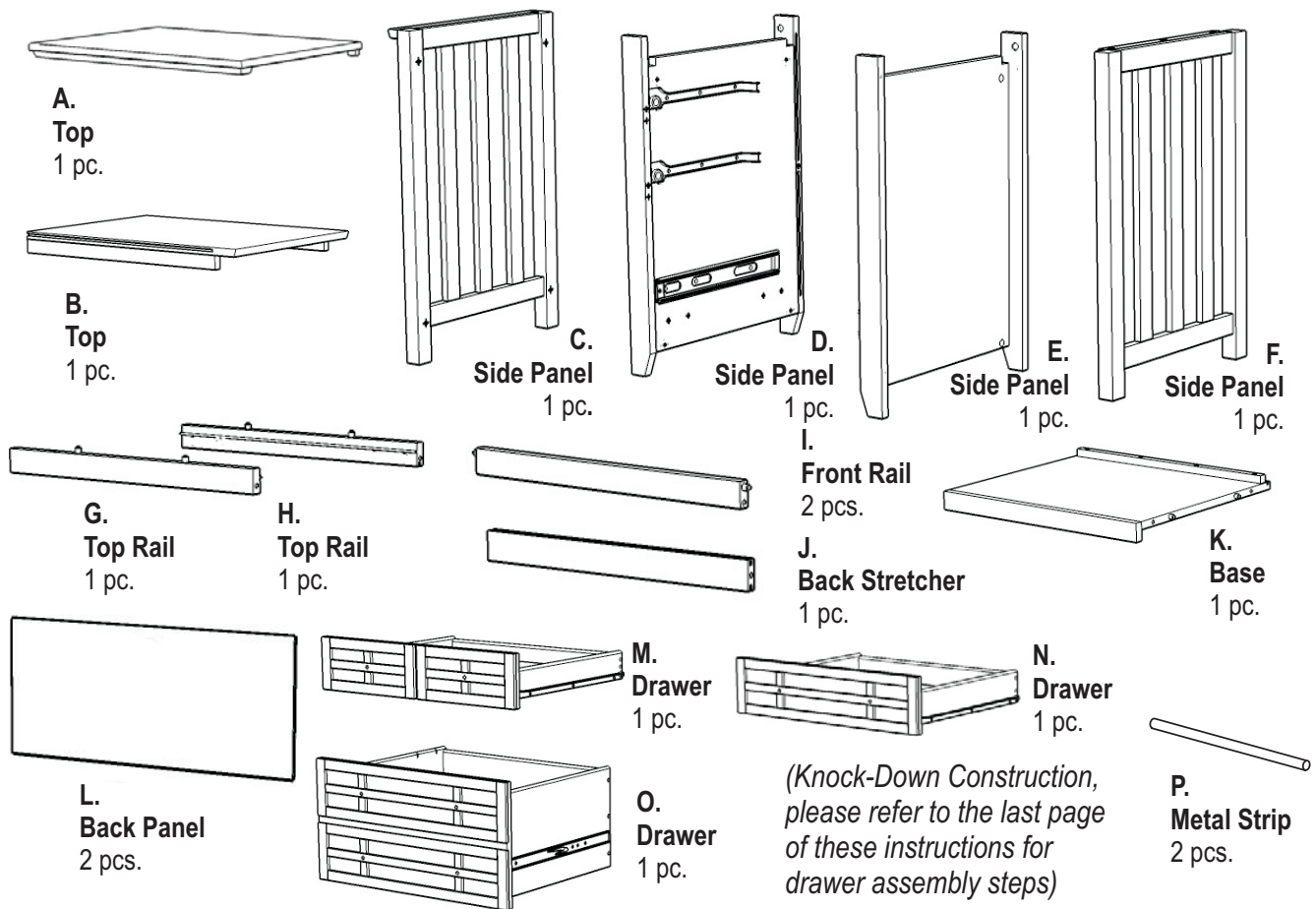

## Hardware List

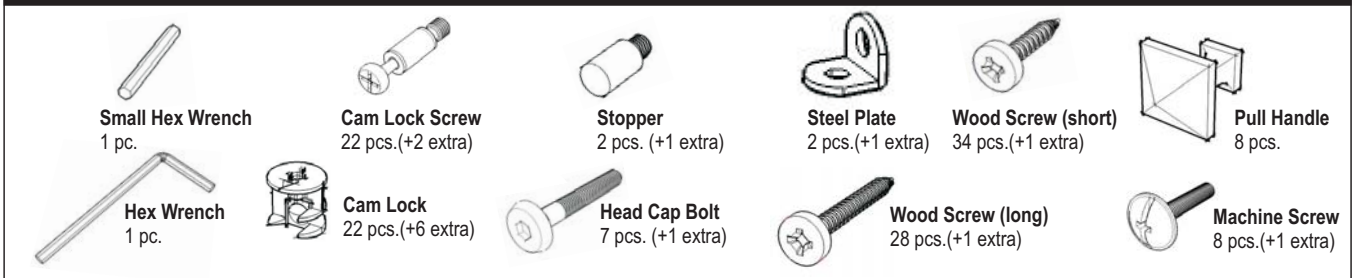

Tools required for assembly : **Phillips** screwdriver

Tools recommended for assembly : Level

Home Styles Consumer Assistance Line 888-680-7460 and 877-831-0319  
[servicedesk@homestyles-furniture.com](mailto:servicedesk@homestyles-furniture.com)

## IMPORTANT

- \* Do not tighten up all the screws until each part is properly assembled.
- \* You should keep Hex Wrench in a safe place as you may need to tighten up the Head Cap Bolts in the future.
- \* Use a soft cloth between these parts and the floor.
- \* After assembly, item must be level to work properly.
- Use the included adjustable levelers to level.

## STEP 1

Insert Cam Lock Screws into the pre-drilled holes of Top (A), Side Panel (D) and (E).

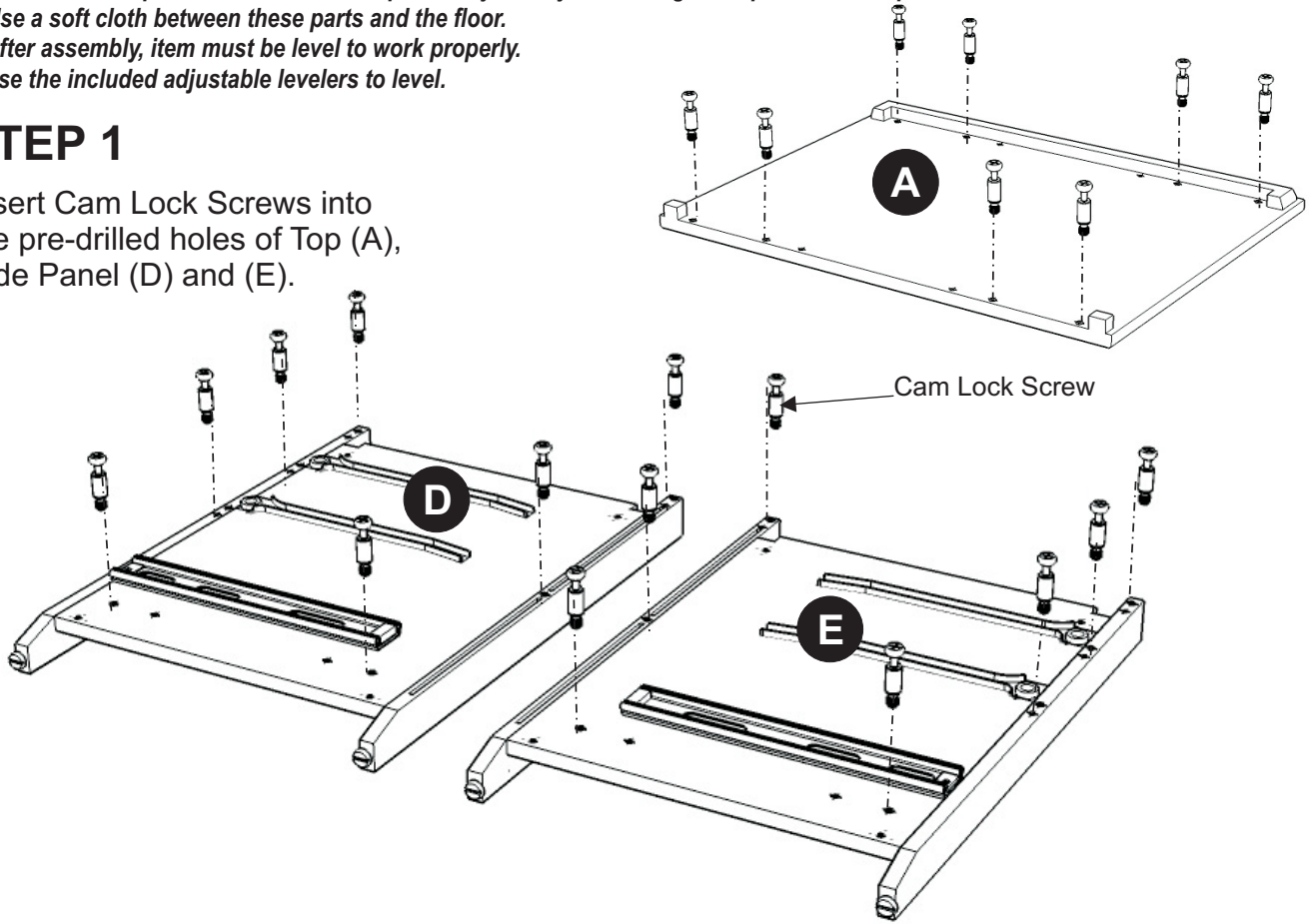

## STEP 2

Attach Top Rail (G) and (H), Front Rails (I) and Back Stretcher (J) to Side Panel (E) with Cam Locks (see Figure 1)

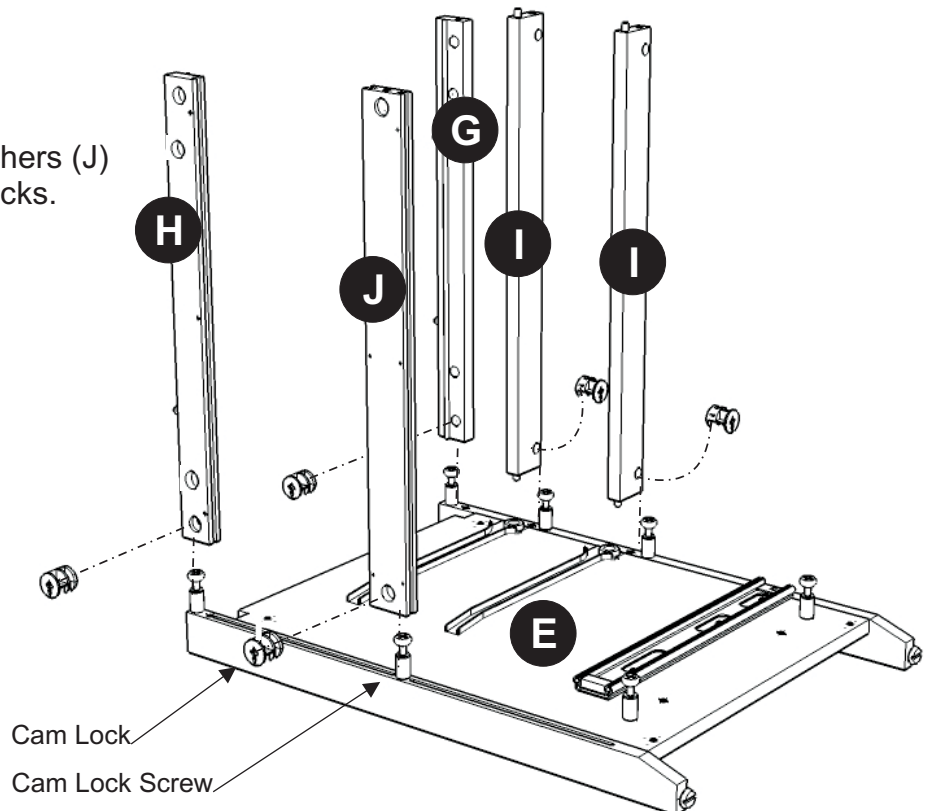
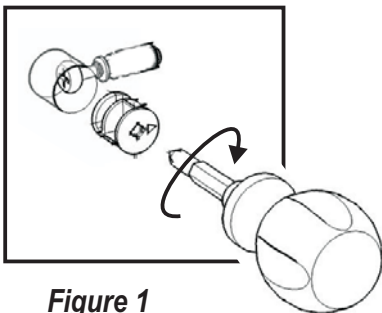

## STEP 3

Attach Base (K) to unit with Cam Locks.

Slide Back Panels (L) into position.

Attach Side Panel (D) to unit with Cam Locks.

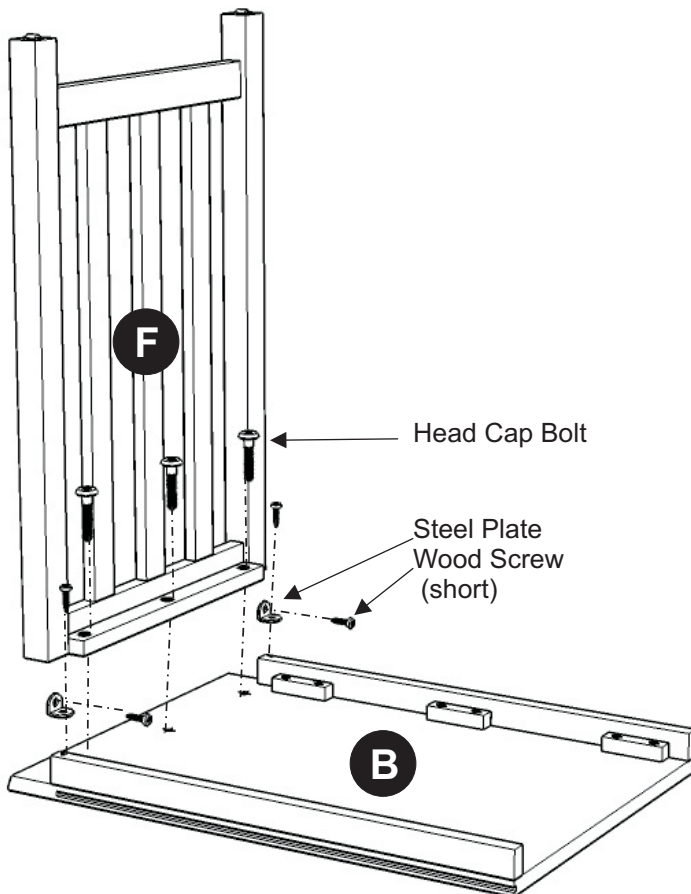
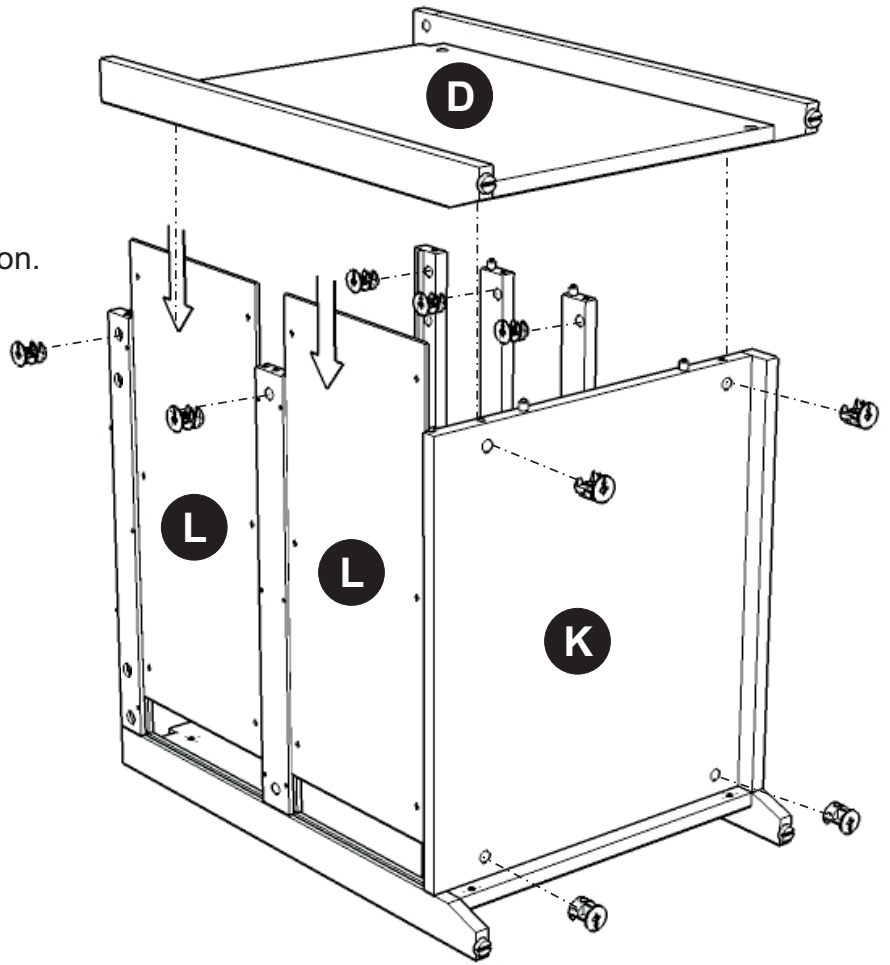

## STEP 4

Attach Side Panel (F) to Top (B) with Head Cap Bolts.

Attach Steel Plates to the unit with Wood Screws (short) into the pre-drilled holes.

Please choose between a left side or right side expanding desk.  
Please follow instructions on this page for left side expansion and on page 5/8 for right side expansion.

## Left Expand-a-Desk Assembly

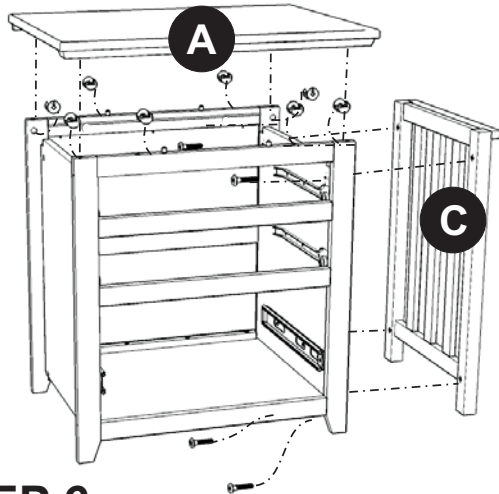

### STEP 5

Attach Side Panel (C) to right side of unit with Head Cap Bolts.

Place Top (A) onto unit with Cam Locks.

### STEP 6

Slide the expand top unit into left side position.

Insert Stoppers into the pre-drilled holes of Top (B) in two places. (See figure 2)

Slide Drawers (M), (N) and (O) into position.

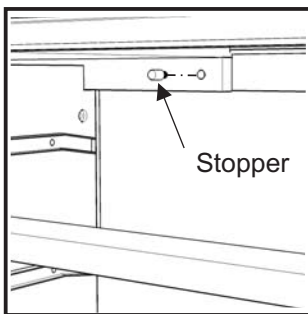
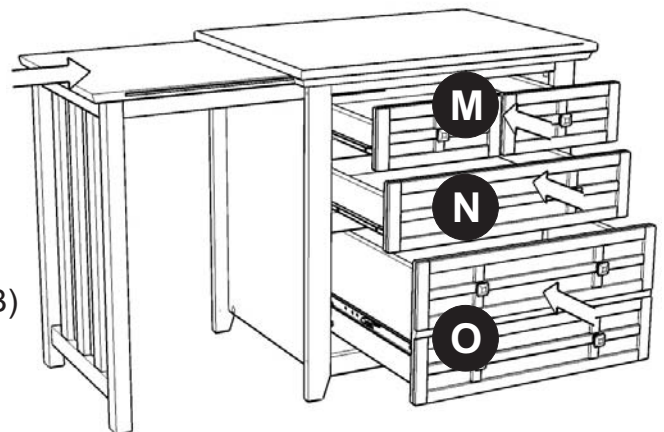
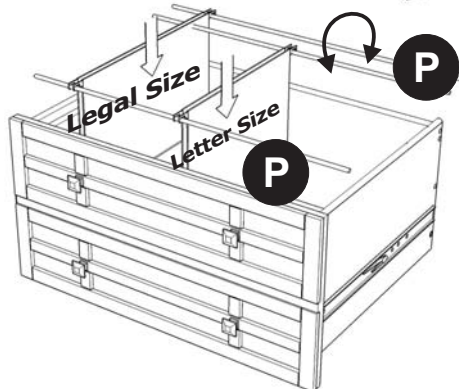

Figure 2



### STEP 7

Place Metal Strips (L) into position.

You can adjust the Metal Strip for letter size or legal size files as shown.

### STEP 8

To level the unit, adjust the adjustable levelers on the bottom of unit. (See figure 3)

Insert 12X Wood Screws from the back of the unit, tighten up all the Wood Screws (short).

**Note: Please make sure unit is level before tightening these screws.**

To change expansion side at a later time, simply follow these instructions in reverse and then follow the instructions on page 5/8 for right side expansion.

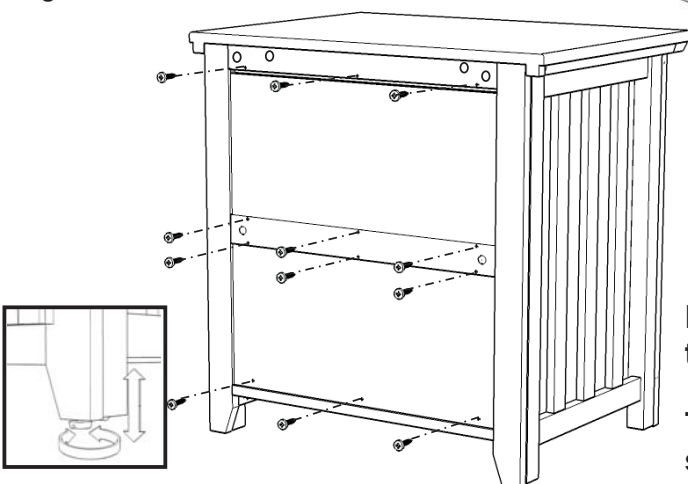
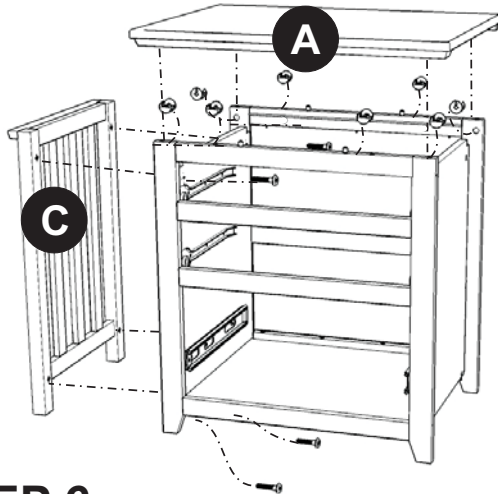
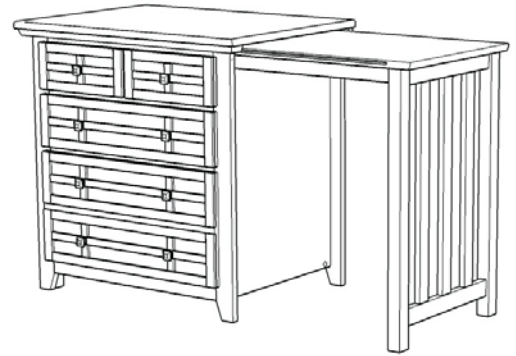

Figure 3

Please choose between a left side or right side expanding desk.  
Please follow instructions on this page for right side expansion and on page 4/8 for left side expansion.

## Right Expand-a-Desk Assembly



### STEP 5

Attach Side Panel (C) to left side of unit with Head Cap Bolts.

Place Top (A) onto unit with Cam Locks.

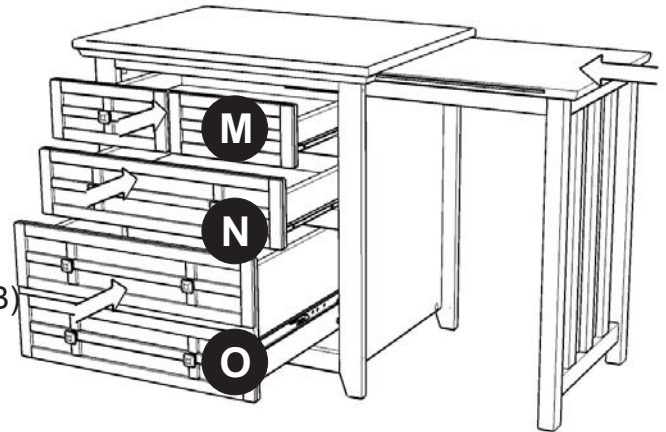

### STEP 6

Slide the expand top unit into right side position.

Insert Stoppers into the pre-drilled holes of Top (B) in two places. (See figure 2)

Slide Drawers (M), (N) and (O) into position.

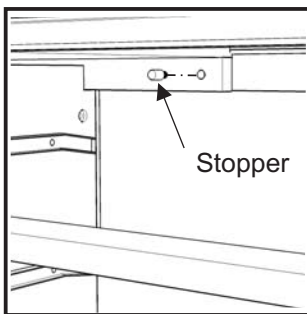
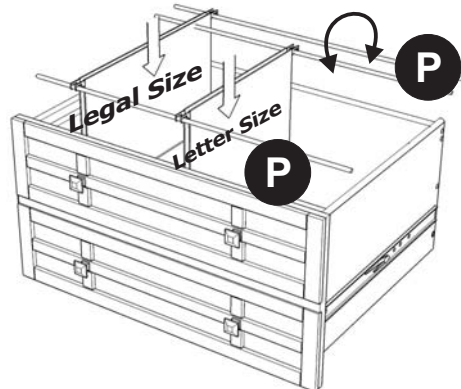

Figure 2



### STEP 7

Place Metal Strips (L) into position.

You can adjust the Metal Strip for letter size or legal size files as shown.

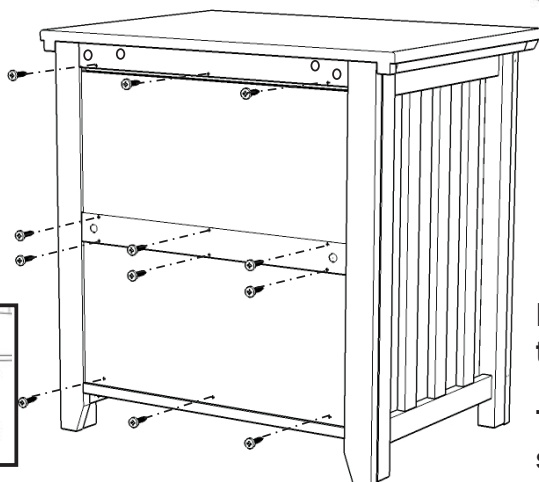

### STEP 8

To level the unit, adjust the adjustable levelers on the bottom of unit. (See figure 3)

Insert 12X Wood Screws from the back of the unit, tighten up all the Wood Screws (short).

**Note: Please make sure unit is level before tightening these screws.**

To change expansion side at a later time, simply follow these instructions in reverse and then follow the instructions on page 4/8 for left side expansion.

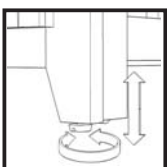

Figure 3

# Drawer (M)

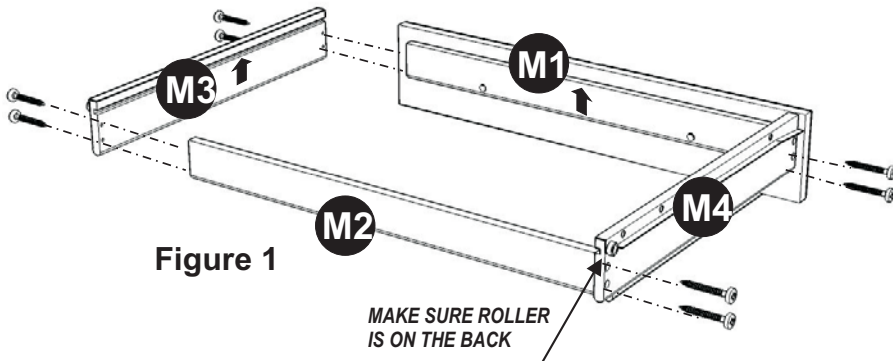
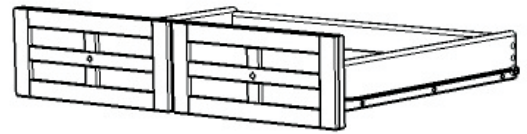

Figure 1

## STEP 1

Attach M1 to M3 and M4, using a Phillips screwdriver and long wood screws (4X), tighten halfway.

Attach M2 to M3 and M4 using long wood screws (4X), tighten halfway. (see Figure 1)

## STEP 2

Slide M5 into the grooves in M3 and M4. Be sure to push M5 all the way forward so it meets M1. (see Figure 2)

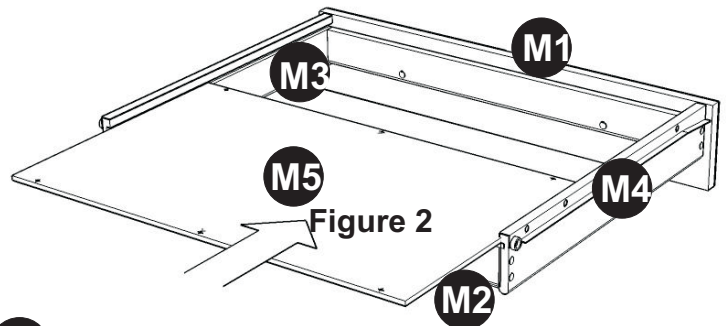

Figure 2

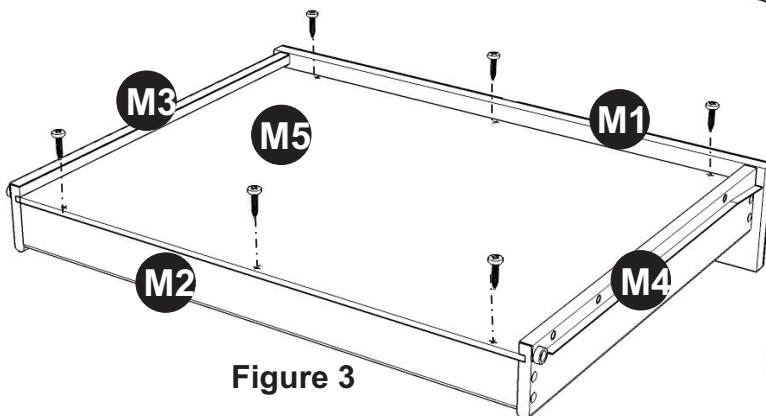

Figure 3

## STEP 3

Insert short wood screws (6X) into the pre-drilled holes in M5, tighten screws. (see Figure 3)

## STEP 4

Assemble Pull Handle with machine screws. (see Figure 4)

Figure 4

Tighten all screws used in drawer assembly.

## Part List

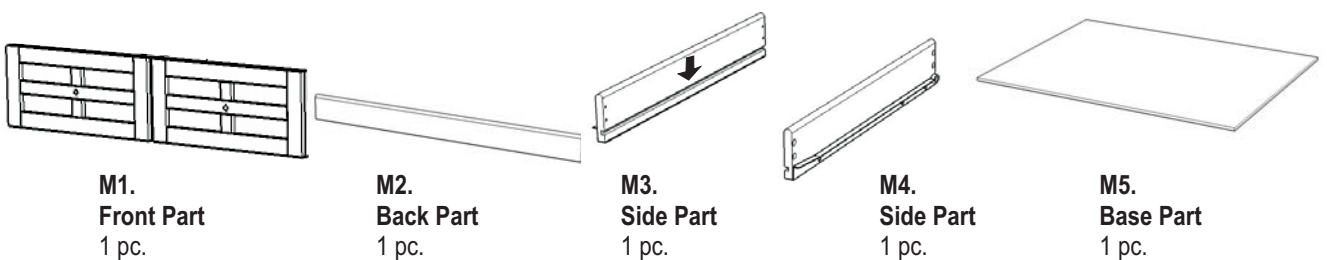

M1.  
Front Part  
1 pc.

M2.  
Back Part  
1 pc.

M3.  
Side Part  
1 pc.

M4.  
Side Part  
1 pc.

M5.  
Base Part  
1 pc.

# Drawer (N)

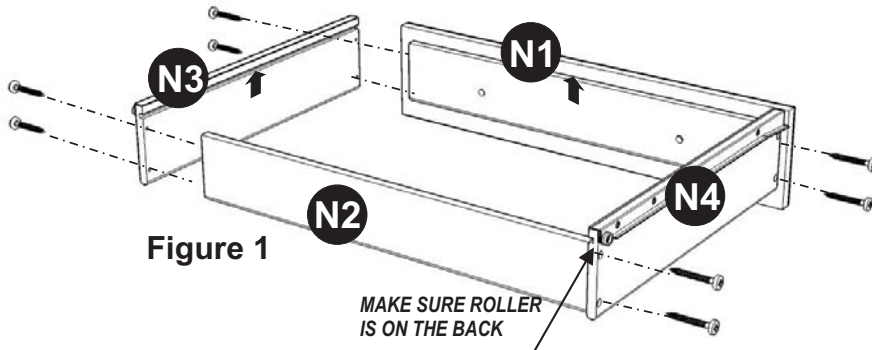
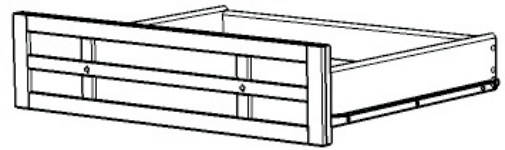

Figure 1

## STEP 1

Attach N1 to N3 and N4, using a Phillips screwdriver and long wood screws (4X), tighten halfway.

Attach N2 to N3 and N4 using long wood screws (4X), tighten halfway. (see Figure 1)

## STEP 2

Slide N5 into the grooves in N3 and N4. Be sure to push N5 all the way forward so it meets N1. (see Figure 2)

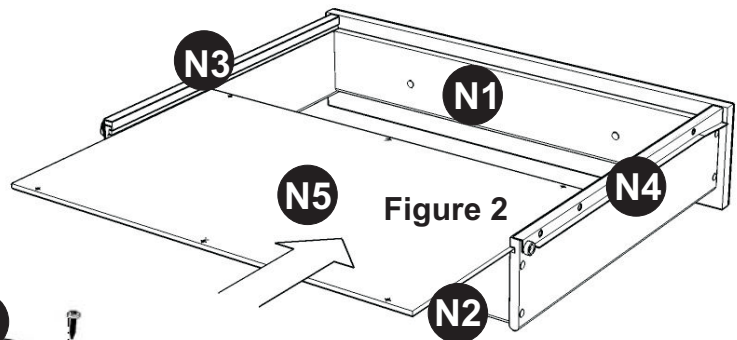

Figure 2

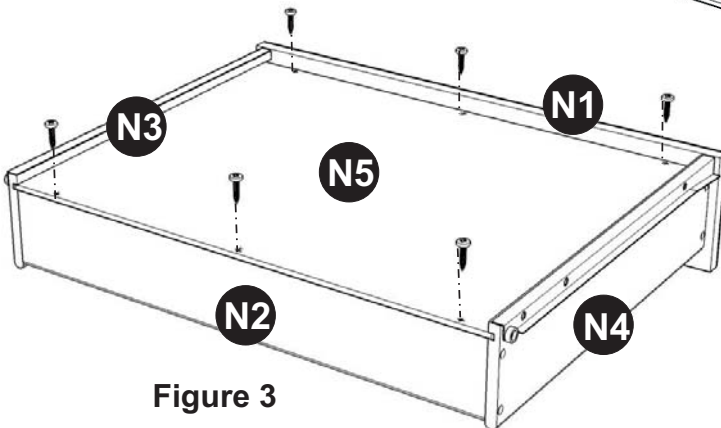

Figure 3

## STEP 3

Insert short wood screws (6X) into the pre-drilled holes in N5, tighten screws. (see Figure 3)

## STEP 4

Assemble Pull Handle with machine screws. (see Figure 4)

Figure 4

Tighten all screws used in drawer assembly.

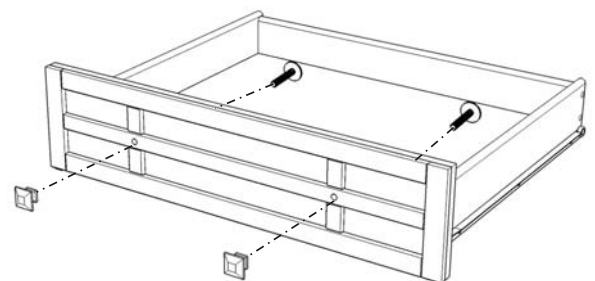

## Part List

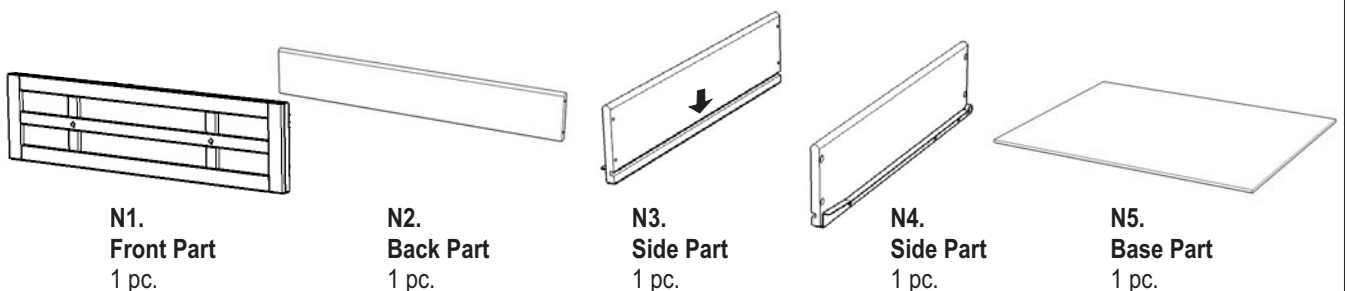

# Drawer (O)

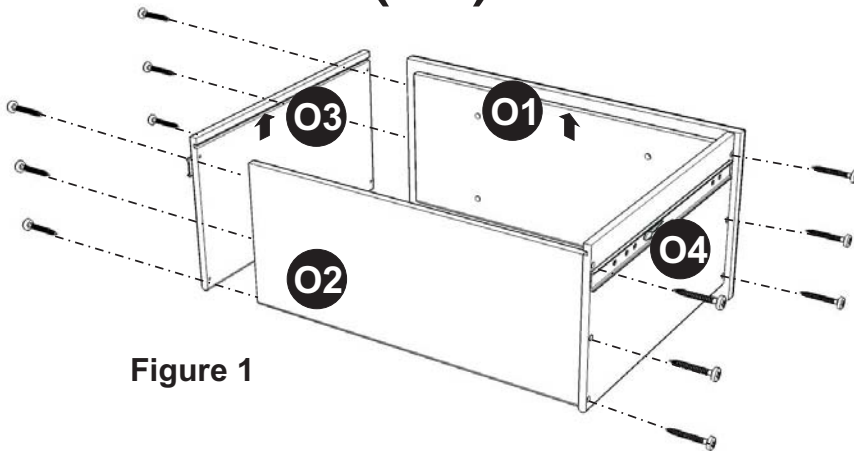
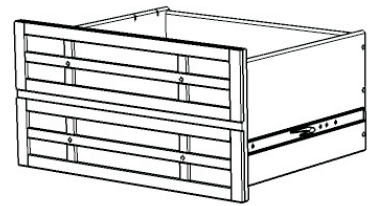

Figure 1



## STEP 1

Attach O1 to O3 and O4 using a Phillips screwdriver and long wood screws (6X), tighten halfway.

Attach O2 to O3 and O4 using long wood screws (6X), tighten halfway. (see Figure 1)

## STEP 2

Slide O5 into the grooves in O3 and O4. Be sure to push O5 all the way forward so it meets O1. (see Figure 2)

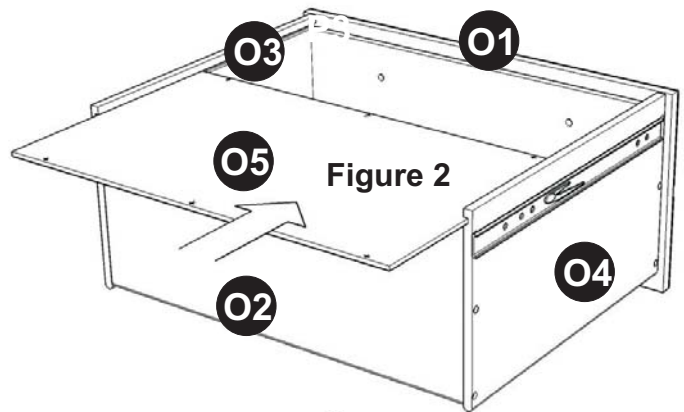

Figure 2

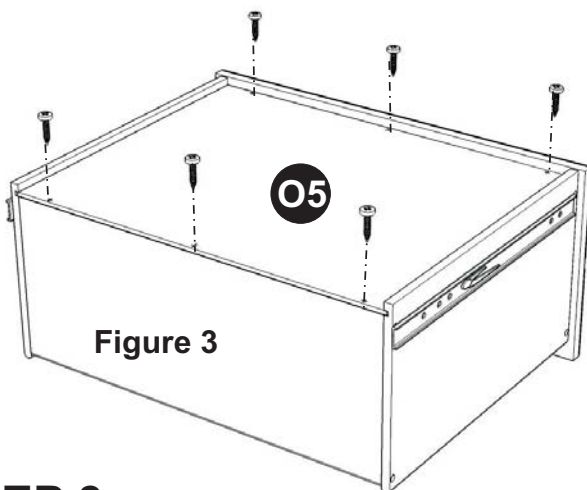

Figure 3

## STEP 3

Insert short wood screws (6X) into the pre-drilled holes in O5, tighten screws. (see Figure 3)

## STEP 4

Assemble Pull Handle with machine screws. (see Figure 4)

Tighten all screws used in drawer assembly.

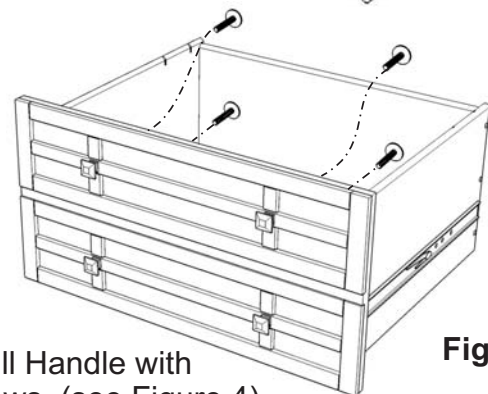
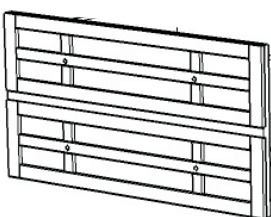
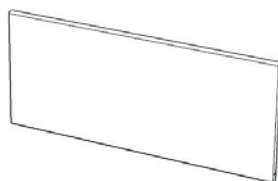

Figure 4

## Part List



O1.  
Front Part  
1 pc.



O2.  
Back Part  
1 pc.

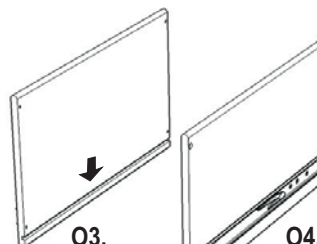

O3.  
Side Part  
1 pc.



O4.  
Side Part  
1 pc.



O5.  
Base Part  
1 pc.