

88 5018 951

The Vintage Kitchen Cart

IMPORTANT NOTE

Carefully remove all the parts from the carton and put them individually on a soft cloth to prevent scratches or other damages occurring to the wood parts.

We have taken great care in the design of this product and request that you carefully and strictly follow our assembly instructions to ensure a completed product as it was designed.

Home Styles

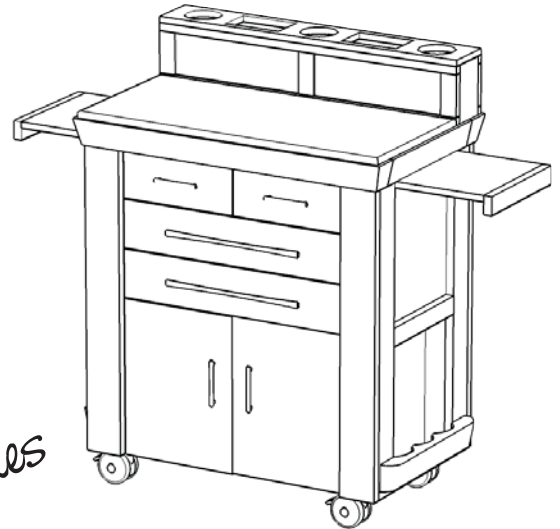

Part List

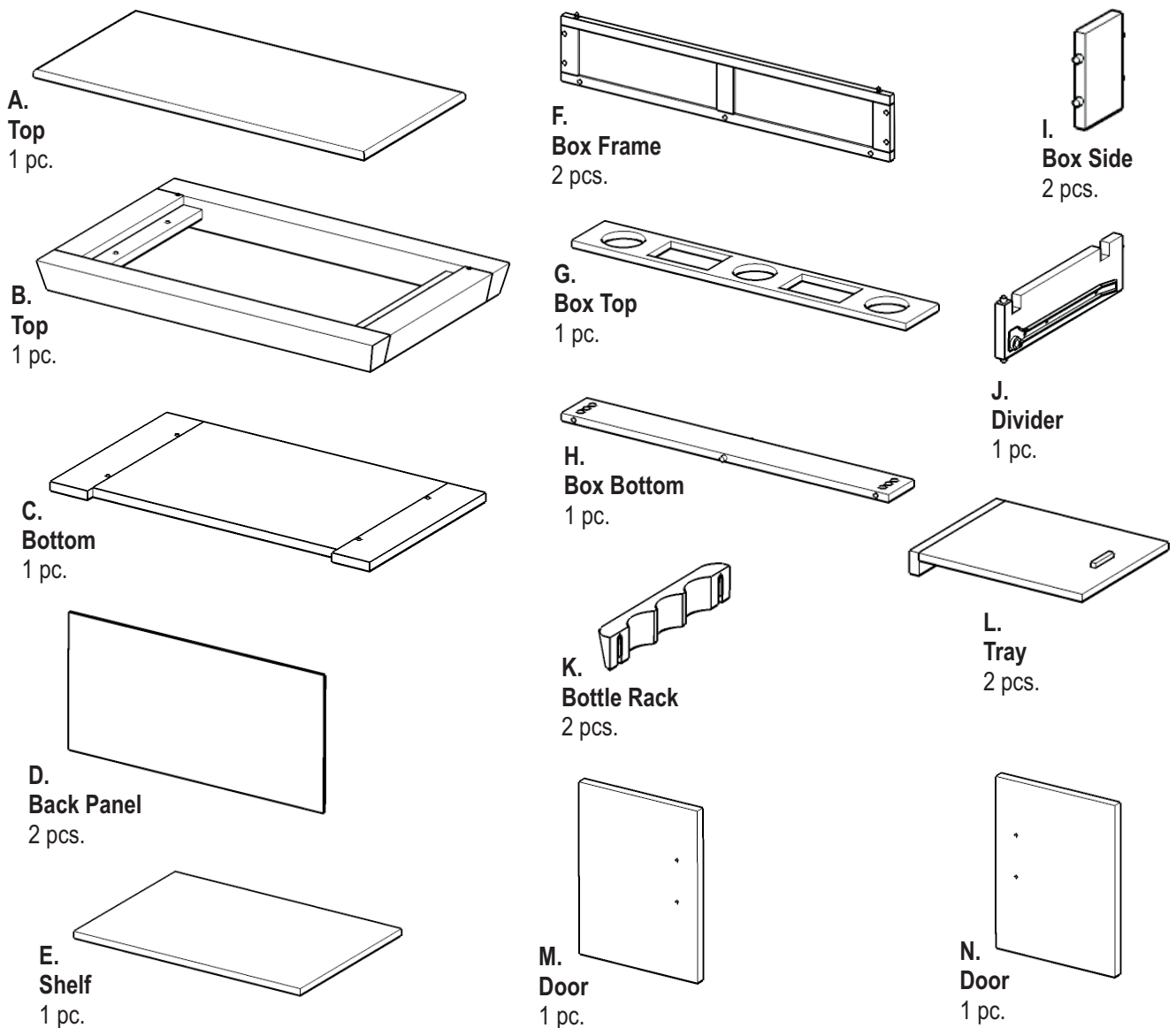

For assembly see instructions in carton 88 5018 952

Tools required for assembly : **Phillips** screwdriver

Tools recommended for assembly : Level

Home Styles Consumer Assistance: www.homestyles-furniture.com,
servicedesk@homestyles-furniture.com, 888-680-7460, 877-831-0319

88 5018 952 The Vintage Kitchen Cart

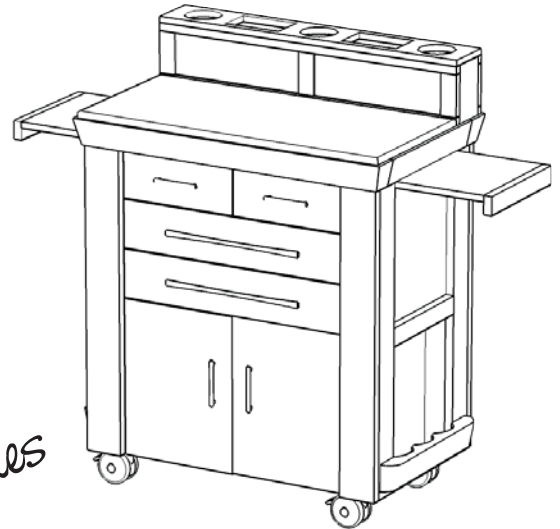

IMPORTANT NOTE

Carefully remove all the parts from the carton and put them individually on a soft cloth to prevent scratches or other damages occurring to the wood parts.

We have taken great care in the design of this product and request that you carefully and strictly follow our assembly instructions to ensure a completed product as it was designed.

Part List

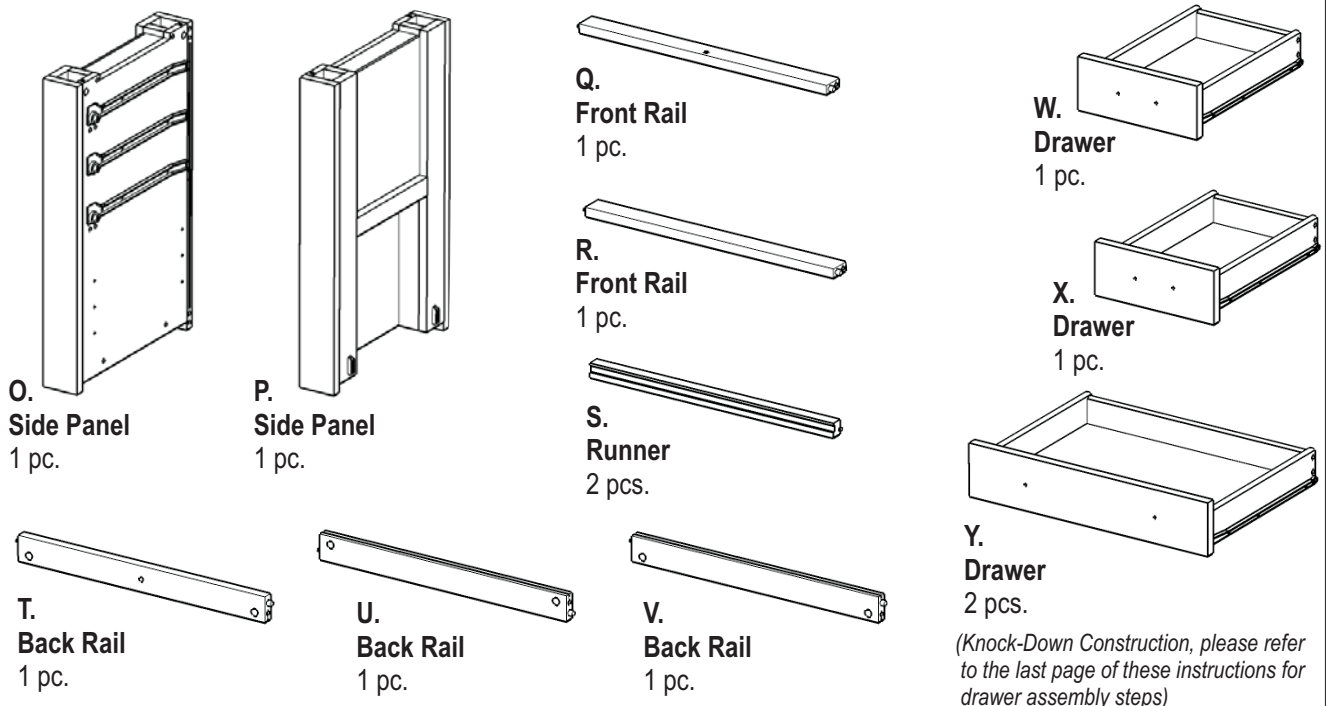

Hardware List

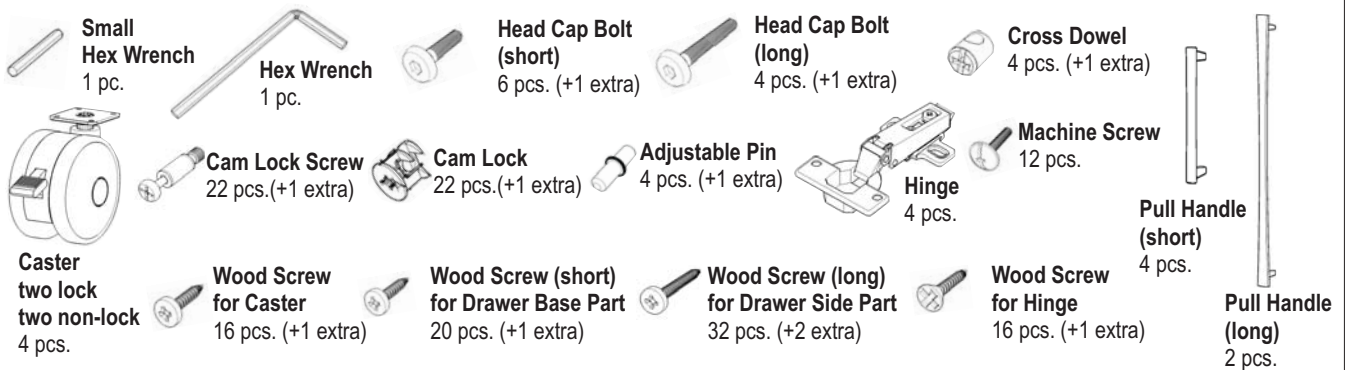

Also need Part in carton 88 5018 951

Tools required for assembly : **Phillips** screwdriver

Tools recommended for assembly : Level

Home Styles Consumer Assistance: www.homestyles-furniture.com,
servicedesk@homestyles-furniture.com, 888-680-7460, 877-831-0319

Assembly Instructions 2/8

IMPORTANT

- * Do not tighten up all the screws until each part is properly assembled.
- * You should keep Hex Wrench in a safe place as you may need to tighten up the Head Cap Bolts in the future.
- * After assembly, item must be level to work properly. Use the included adjustable levelers to level.
- * Use a soft cloth between these parts and the floor.

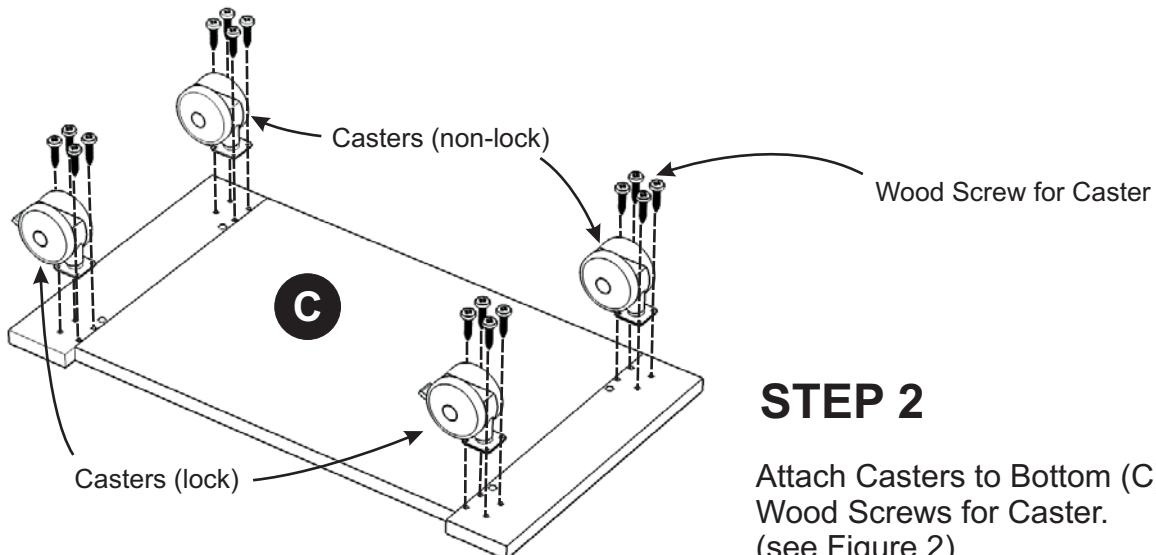
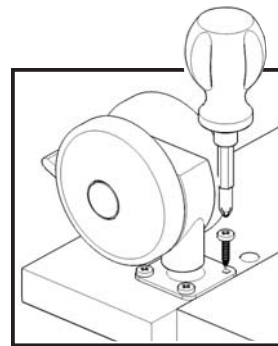
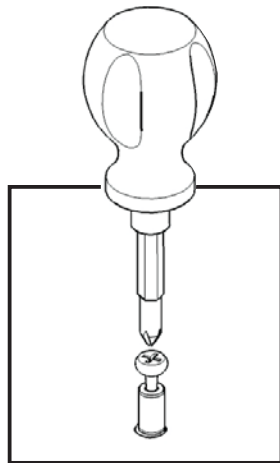
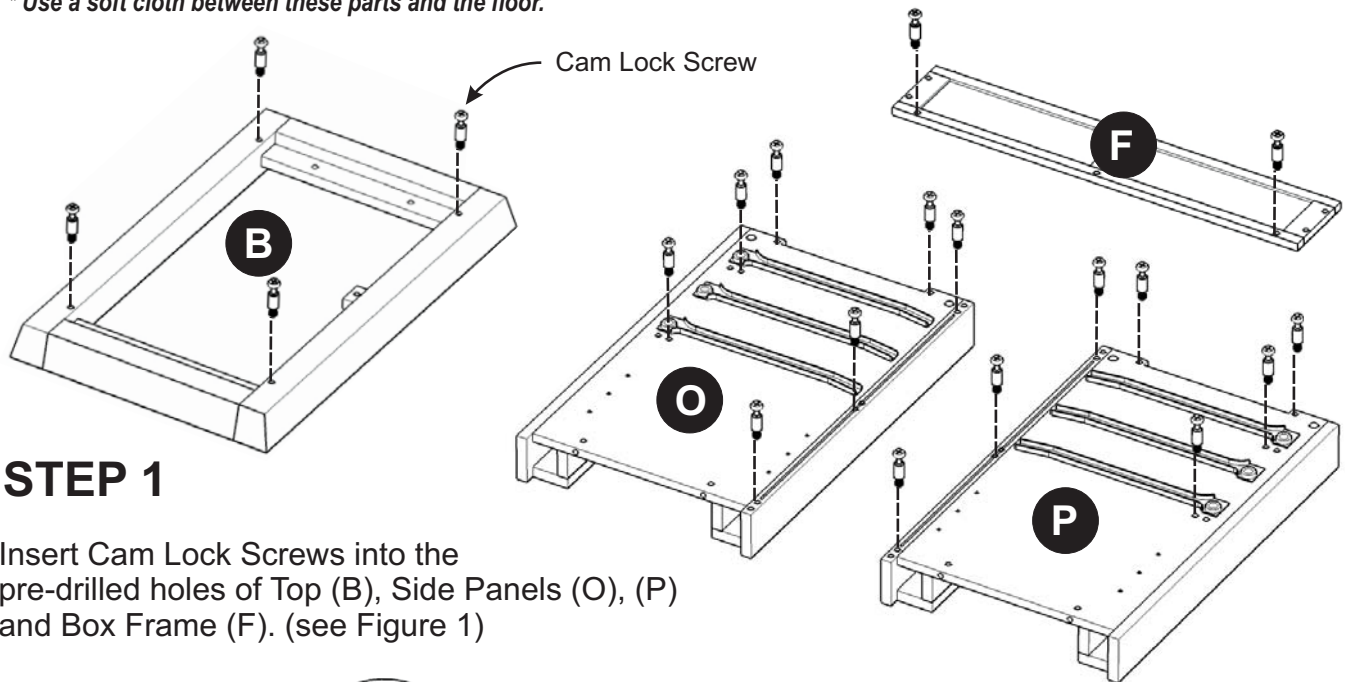

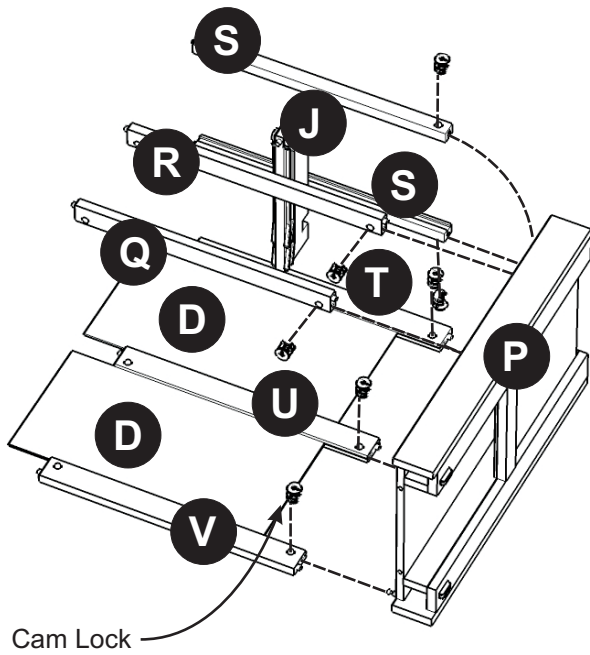

STEP 3

Attach Back Rail (T), (U) and (V) to Side Panel (P) using Cam Locks (see Figure 3), then slide Back Panels (D) into place.

Attach Front Rail (Q), (R) to the unit using Cam Locks.

Attach Divider (J) and Runners (S) to unit using Cam Locks.

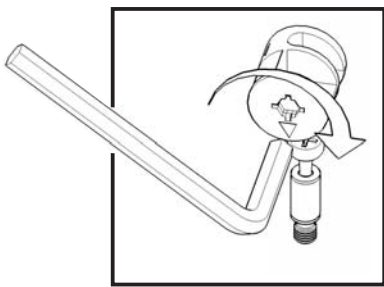

Figure 3

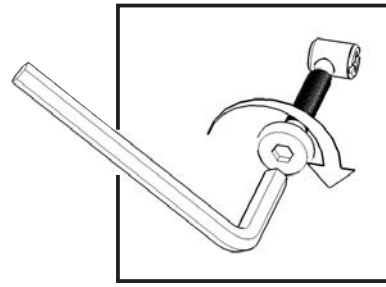
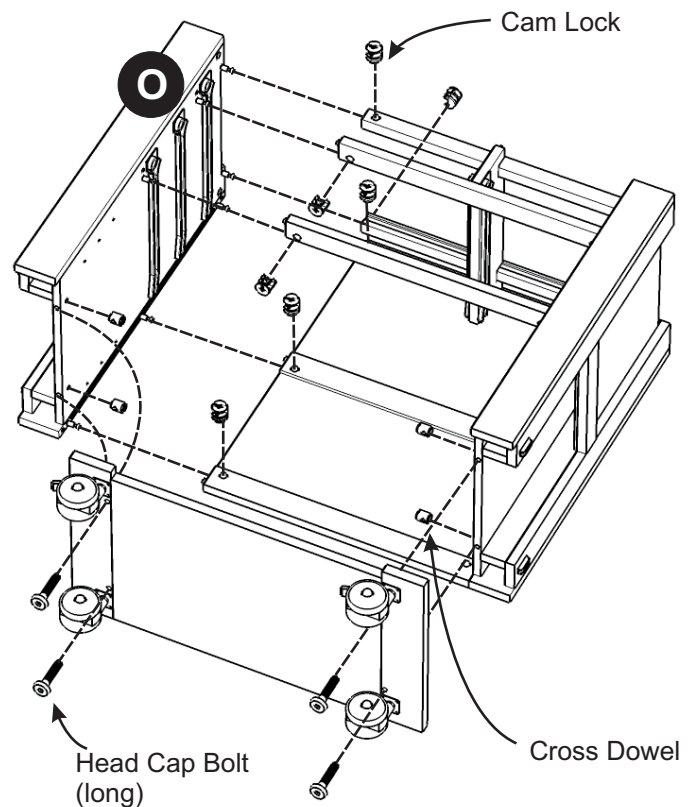

Figure 4

STEP 4

Attach Side Panel (O) to the unit using Cam Locks.

Attach bottom unit to unit with Head Cap Bolts (long) and Cross Dowels. (see Figure 4)



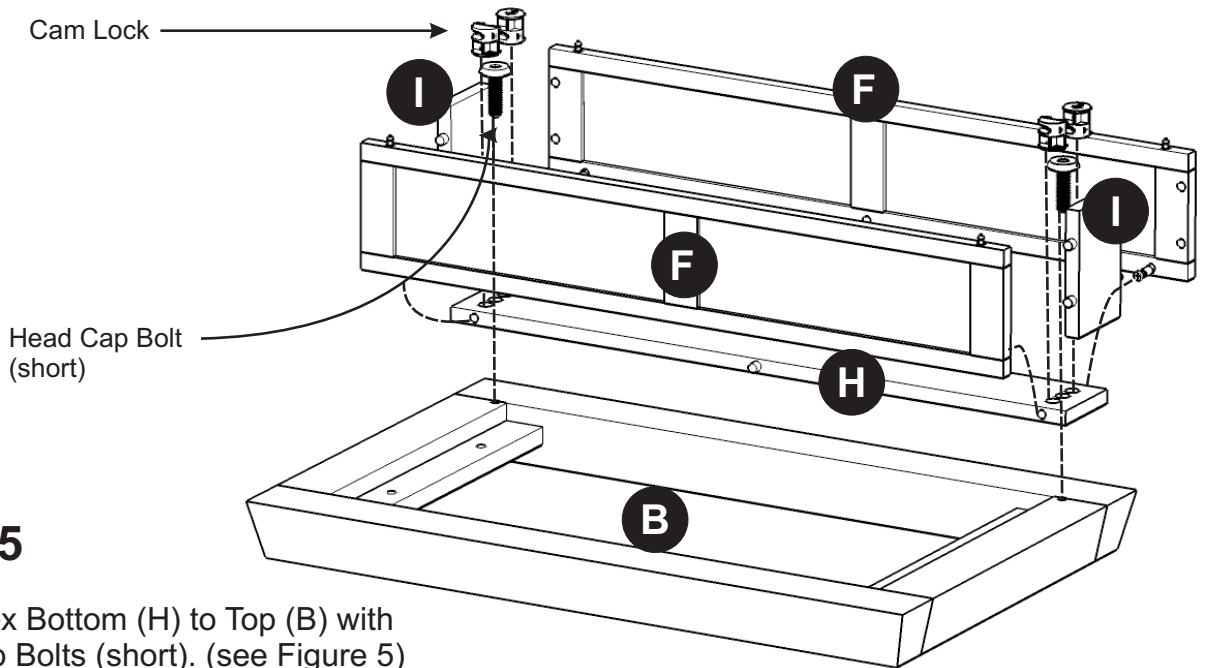

STEP 5

Attach Box Bottom (H) to Top (B) with Head Cap Bolts (short). (see Figure 5)

Attach Box Frames (F) and Box Sides (I) to top unit using Cam Locks.

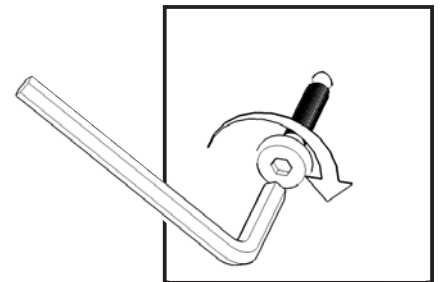
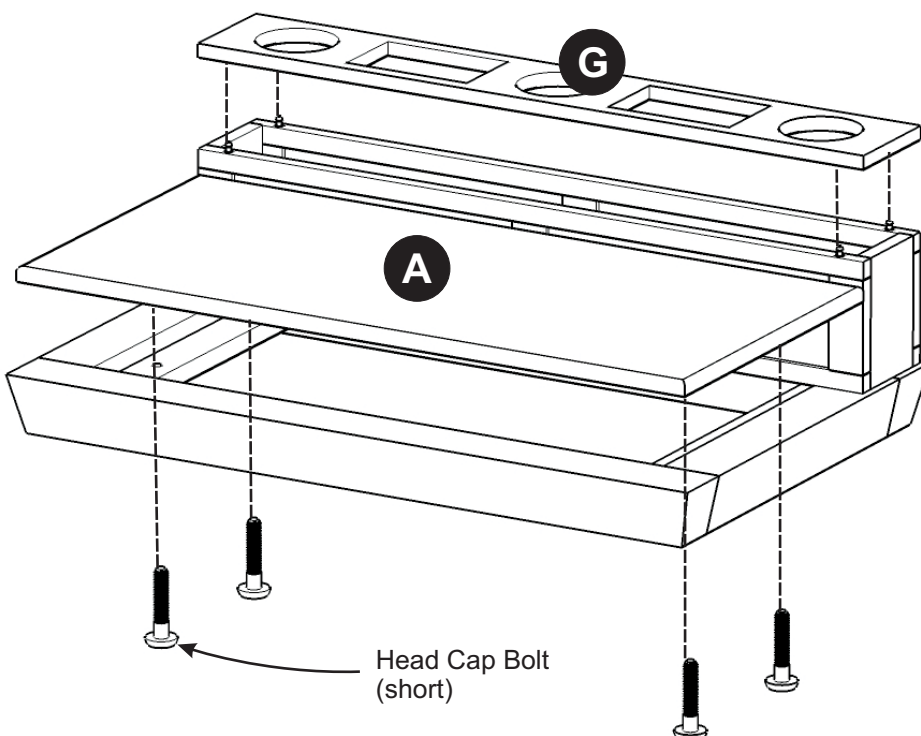

Figure 5



STEP 6

Attach Top (A) to top unit with Head Cap Bolts (short).

Place Box Top (G) onto box unit.

Assembly Instructions 5/8

Wood Screw for Hinge

Hinge

STEP 7

Attach Hinges to Door (M), (N) with Wood Screws for Hinge. (see Figure 6)

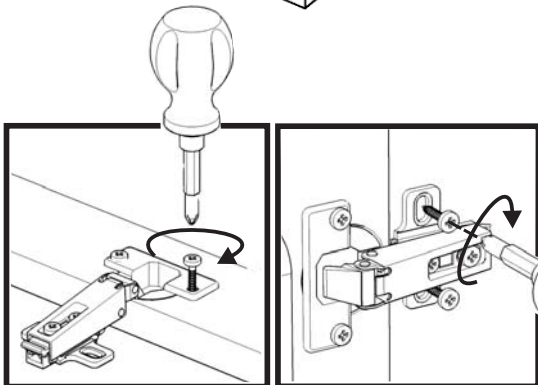
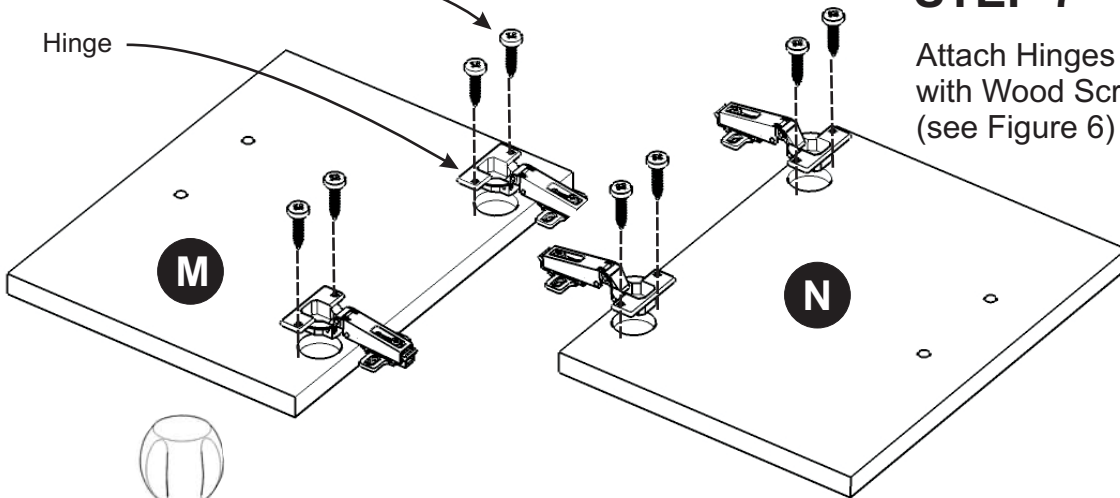

Figure 6

Figure 7

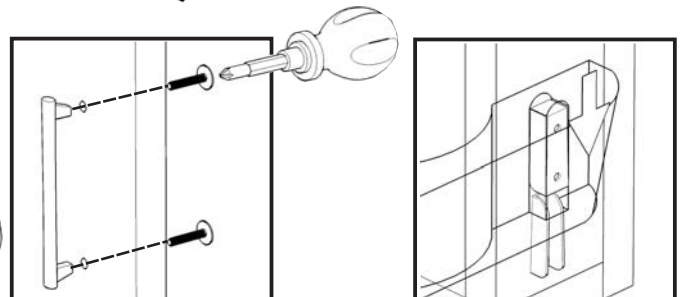

Figure 8

Figure 9

STEP 8

Slide Trays (L) into position.

Place top unit onto unit using Cam Locks.

Attach Door (M) and (N) to unit with Wood Screws for Hinge. (see Figure 7)

Assemble Pull Handles to Doors (M) and (N) with Machine Screws. (see Figure 8)

Insert Adjustable Pins into side panels.

Place Shelf (E) into position.

Slide Bottle Racks (K) down onto side panels. (see Figure 9)

Slide Drawers (W), (X) and (Y) into position.

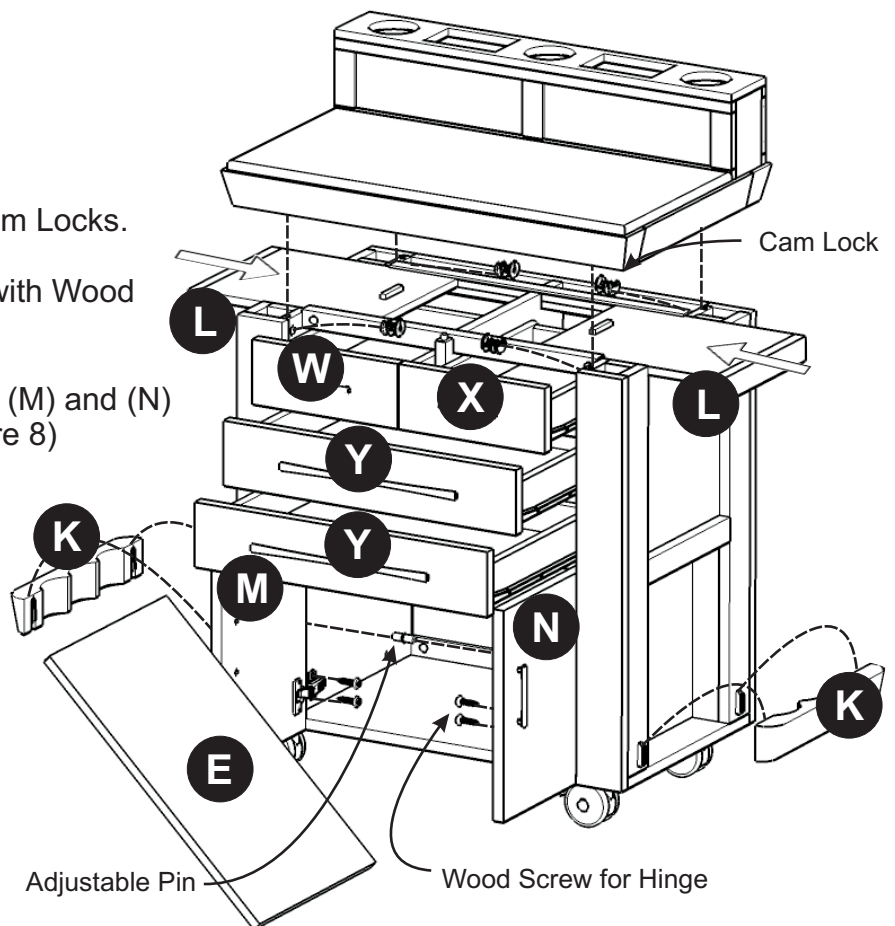

Drawer (W)

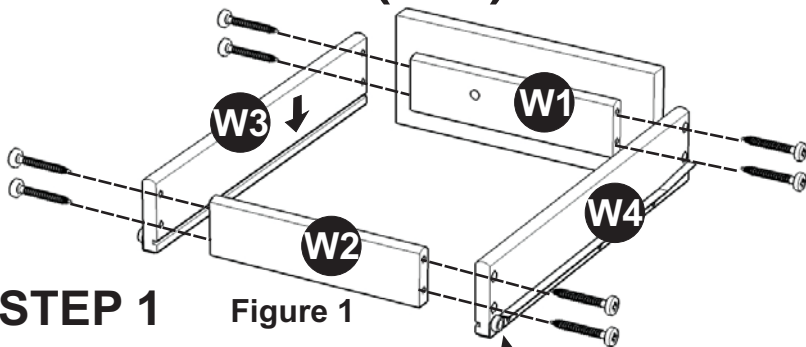

STEP 1 Figure 1

Attach W1 to W3 and W4, using a Phillips screwdriver and long wood screws (4X), tighten halfway.

MAKE SURE ROLLER IS ON THE BACK

Attach W2 to W3 and W4 using long wood screws (4X), tighten halfway. (see Figure 1)

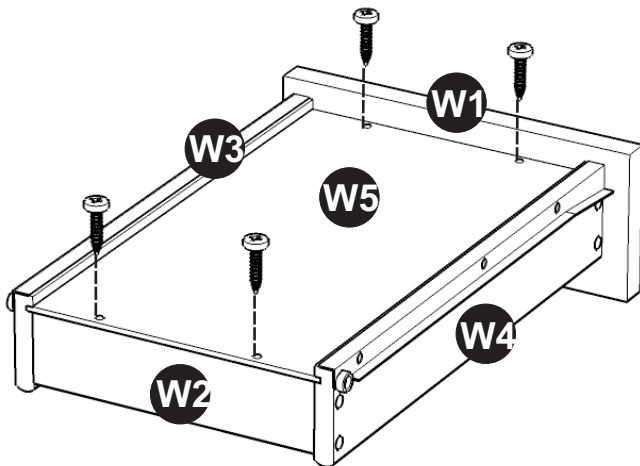

Figure 3

STEP 3

Insert short wood screws (4X) into the pre-drilled holes in W5 and tighten. (see Figure 3)

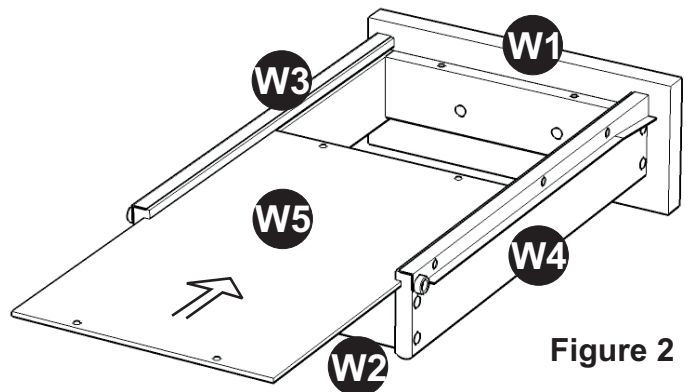
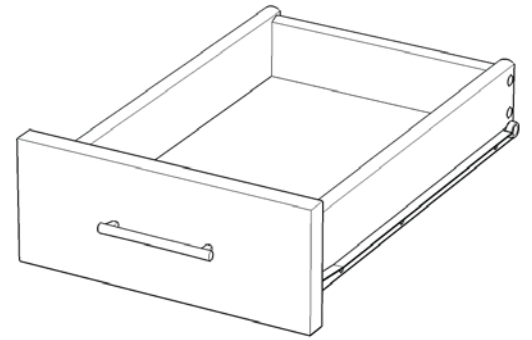

Figure 2

STEP 2

Slide W5 into the grooves in W3 and W4. Be sure to push W5 all the way forward so it meets W1. (see Figure 2)

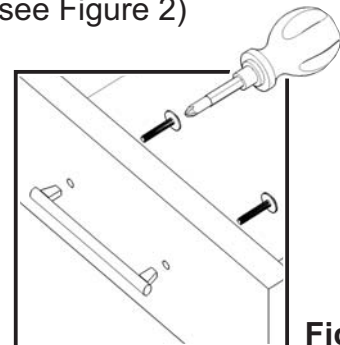

Figure 4

STEP 4

Assemble Pull Handle with machine screws. (see Figure 4)

Tighten all screws used in drawer assembly.

Part List

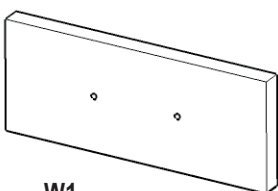

W1.
Front Part
1 pc.

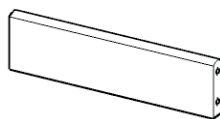

W2.
Back Part
1 pc.

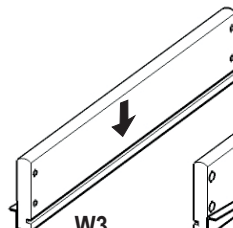

W3.
Side Part
1 pc.

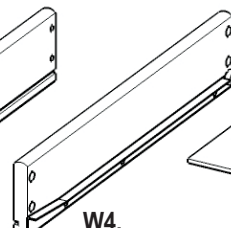

W4.
Side Part
1 pc.

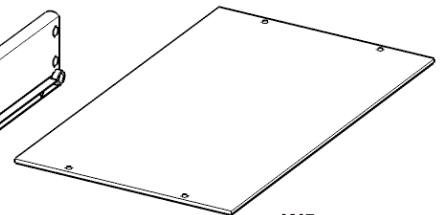

W5.
Base Part
1 pc.

Drawer (X)

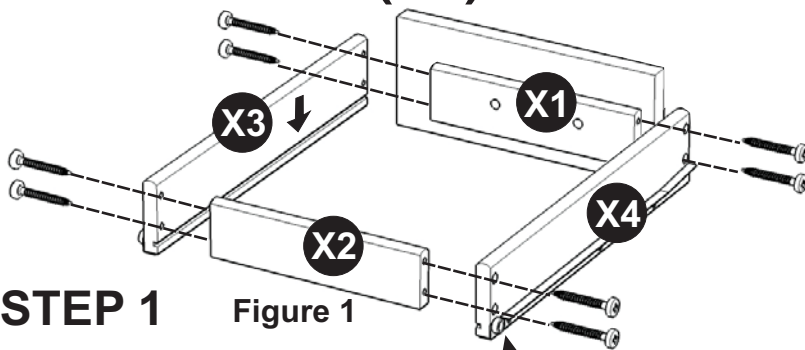

STEP 1 Figure 1

Attach X1 to X3 and X4, using a Phillips screwdriver and long wood screws (4X), tighten halfway.

Attach X2 to X3 and X4 using long wood screws (4X), tighten halfway. (see Figure 1)

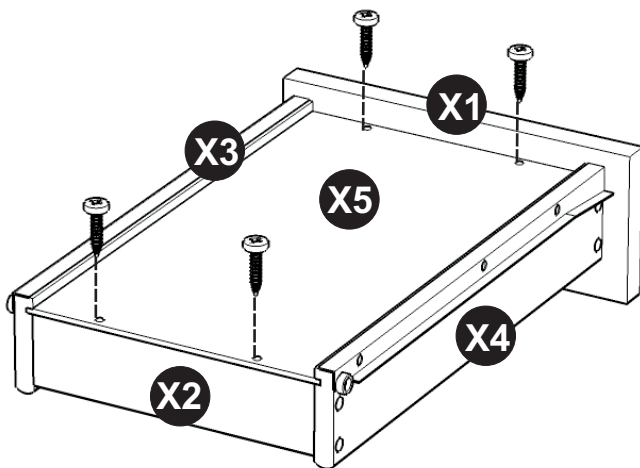

Figure 3

STEP 3

Insert short wood screws (4X) into the pre-drilled holes in X5 and tighten. (see Figure 3)

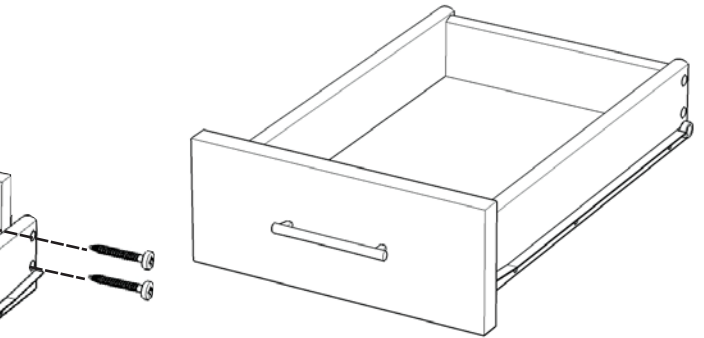

Figure 2

STEP 2

Slide X5 into the grooves in X3 and X4. Be sure to push X5 all the way forward so it meets X1. (see Figure 2)

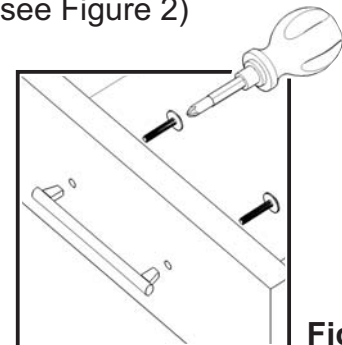

Figure 4

STEP 4

Assemble Pull Handle with machine screws. (see Figure 4)

Tighten all screws used in drawer assembly.

Part List

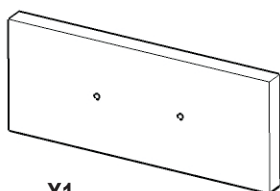

X1.
Front Part
1 pc.

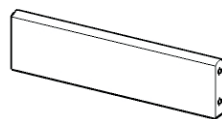

X2.
Back Part
1 pc.

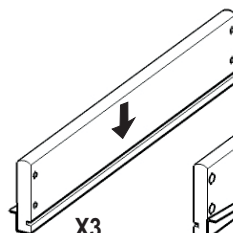

X3.
Side Part
1 pc.

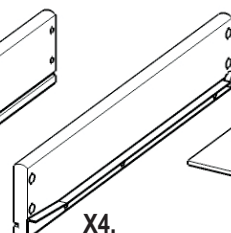

X4.
Side Part
1 pc.

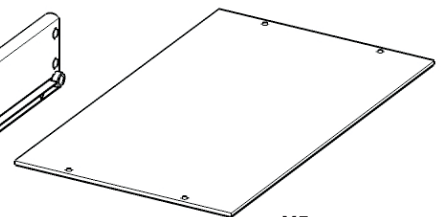

X5.
Base Part
1 pc.

Drawer (Y)

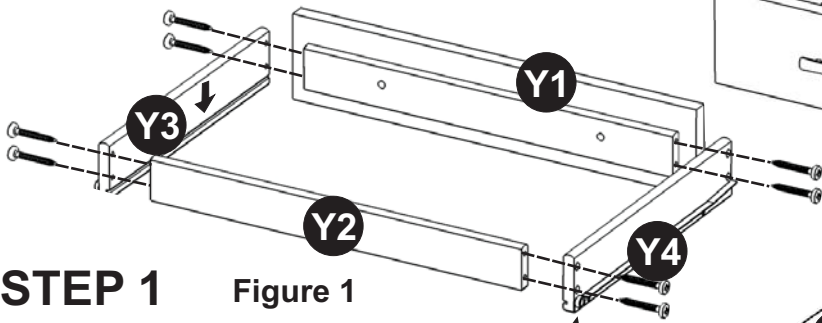

STEP 1 Figure 1

Attach Y1 to Y3 and Y4, using a Phillips screwdriver and long wood screws (4X), tighten halfway.

Attach Y2 to Y3 and Y4 using long wood screws (4X), tighten halfway. (see Figure 1)

MAKE SURE ROLLER IS ON THE BACK

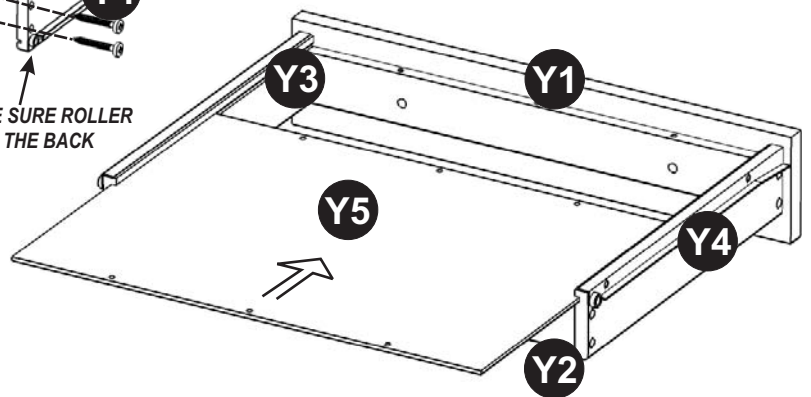

Figure 2

STEP 2

Slide Y5 into the grooves in Y3 and Y4. Be sure to push Y5 all the way forward so it meets Y1. (see Figure 2)

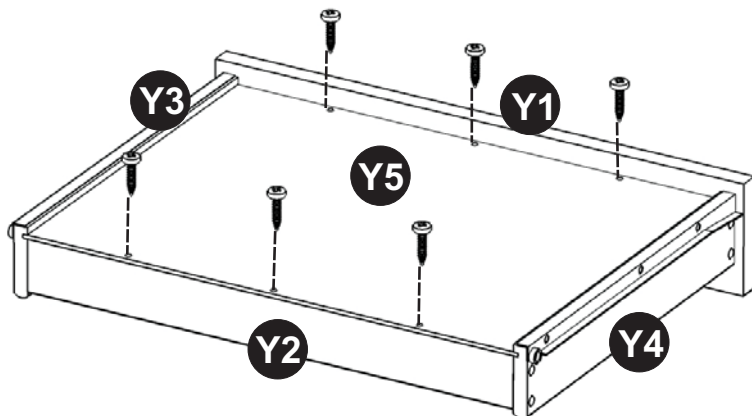

Figure 3

STEP 3

Insert short wood screws (6X) into the pre-drilled holes in Y5 and tighten. (see Figure 3)

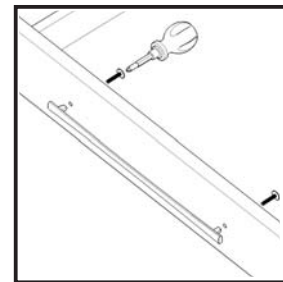

Figure 4

STEP 4

Assemble Pull Handle with machine screws. (see Figure 4)

Tighten all screws used in drawer assembly.

Part List

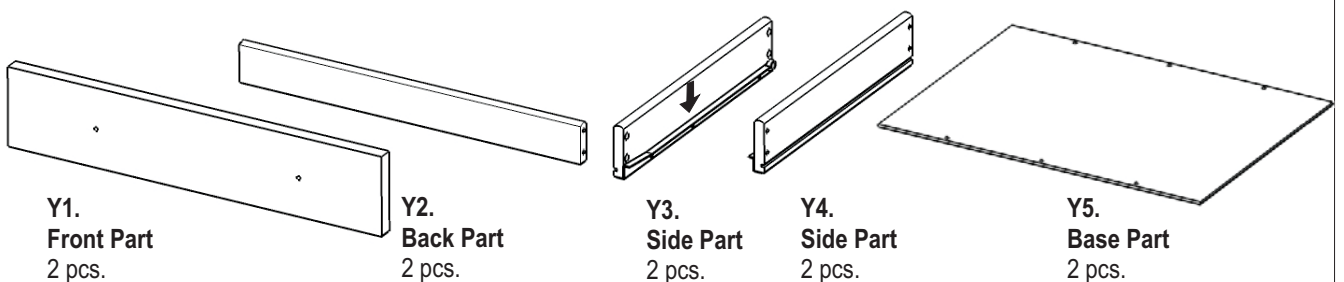

Y1.
Front Part
2 pcs.

Y2.
Back Part
2 pcs.

Y3.
Side Part
2 pcs.

Y4.
Side Part
2 pcs.

Y5.
Base Part
2 pcs.