

boxis[™]
autoshred

A REVOLUTION IN PRODUCTIVITY

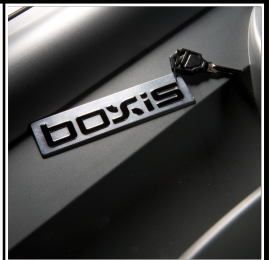

Model# RS700

www.boxisautoshred.com

A Revolution in Productivity

Our innovative paper feeder mechanism grabs documents one at a time from the middle and shreds them into unreadable microcut particles.

The Boxis™ AutoShred™ automates large shred jobs. It only takes seconds to load and start – destroys a full load in approximately 10-12 minutes – you no longer need to stand there while the paper is being shredded. Just place up to 700 sheets of letter size loose leaf paper into the lockable paper tray, press start and walk away...and let the Boxis™ AutoShred™ do the work!

The Boxis™ AutoShred™ reduces a letter size sheet into over 1000 unreadable particles.

3-Year Limited Product Warranty

Covers workmanship and product defect(s), including parts and labor. If unit cannot be repaired, manufacturer will replace with a new unit or comparable unit, at manufacturer's sole discretion. Does NOT cover any repair due to normal wear and tear.

Customer Support:

866-707-1854

support@boxisautoshred.com

Table of Contents

Warnings	2
Specifications.....	3
Installation.....	4
Safety Instructions	4
Shredder Diagram.....	5
General Operation Instructions.....	6 - 8
Secure Shredding Instructions.....	9
LCD Panel Guide.....	10 - 11
Maintenance.....	12
Warranty, Registration & Contact Info.....	13

See product demo video at:
www.boxisautoshred.com



WARNINGS



CAUTION: KEEP THIS DEVICE AWAY FROM CHILDREN AND PETS!
Place the paper shredder in an area less accessible to children.



DO NOT PLACE FINGERS TOO CLOSE TO THE FEED SLOT AS SERIOUS INJURY MAY OCCUR. Paper shredders can pull children's fingers into the shredder mechanism.



AVOID GETTING LOOSE CLOTHING OR JEWELRY NEAR THE FEED SLOT.



AVOID GETTING HAIR NEAR THE FEED SLOT.



NEVER spray any aerosol-based products in or around the shredder. NEVER use any petroleum based or flammable oils or lubricants in or around the machine, as some oils can combust causing serious injury. Lubricants specifically designed for shredders are acceptable.



DO NOT SHRED CREDIT CARDS.



DO NOT SHRED CD/DVD DISCS.



DO NOT SHRED BINDER CLIPS OR PAPER CLIPS.
To reduce premature wear and tear of the rollers, whenever possible remove paper clips and staples from paper before shredding.

**NEVER place the shredder near water or any heat source.
Avoid direct contact with water.**



STOP USE IMMEDIATELY IF:



1. The shredder motor makes loud and/or irregular noises during operation.
2. Smoke or a burning odor becomes present.

Continuing to operate your shredder with any of the above conditions present could be potentially dangerous.

The Boxis™ AutoShred™ RS700



Technical Specifications

Model	RS700
Cutting Style	Micro-Cut
Shred Size	0.1" x 0.7" (3 x 20mm)
DIN Security Level.....	Level 3
Sheet Capacity	700 sheet Autofeed 6-Sheet Manual Feed
Shred Speed.....	22.6 ft/min (6.9 m/min)
Intake Throat Width.....	9.4" (240mm)
Motor Power.....	0.67 HP
Voltage	120V/60Hz
Dimensions (L x W x H).....	21.5" x 17" x 36" (545 x 430 x 915mm)
Weight.....	117 lb (53 kg)
Receptacle Volume.....	21 gallons (80 liters)
Noise Level	<58 dB (Ultra Quiet)

Installation

- Refer to set-up instructions printed on carton box for proper assembly.
- Only operate this product from the type of power source indicated on the marking label. If you are not sure of the type of power available, consult an electrician.
- Make sure the electrical outlet is easily accessible from the shredder.
- Shredder must be operated only in upright position.
- To make sure the shredder has proper ventilation, place it a minimum distance of 5cm (2 inches) from the wall or furniture.

Safety Instructions

1. Read and follow all instructions before use. Save these instructions for later use.
2. Always turn off and unplug the machine before moving, servicing, cleaning, or anything other than normal operation. Serious injury may result. Clean shredder with a damp cloth, using a mild soap and water solution.
3. Do not use abrasives or petroleum-based cleaners.
4. Place this product as close as possible to power source for quick and easy unplugging.
5. Turn off the power switch before removing waste bin. It is advisable to disconnect the power cord before opening the shredder.
6. This product should never be placed near a radiator or other heat source.
7. Do not allow anything to rest on the power cord. Do not place the power cord where people may walk on the it.
8. If an extension cord is used with this product, make sure the total of the ampere (amps) ratings on the products plugged into the extension cord do not exceed the extension cord's ampere rating.
9. Do not attempt to service this product yourself, as in opening or removing covers may expose you to risks of getting injured. Also, doing this will void the warranty of the shredder.
10. Unplug this product and contact technical support when:
 - The power cord or plug is damaged or frayed.
 - Liquid has been spilled on the product.
 - The product has been exposed to rain.
 - The product does not operate normally even when the operating instructions are followed.
 - The product has been dropped, or the casing has been damaged.
11. Regularly empty the waste bin so that the waste output is not impeded.

Diagram

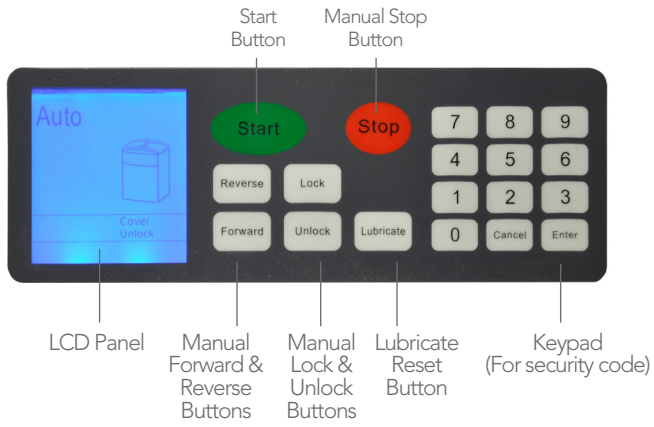

Operation

Read instructions completely before operating shredder.

Connect power cord to the power socket at the backside of the machine.
Connect the power cord to any standard 120V AC, 60Hz outlet.

Install waste bin

- Open cabinet door and remove waste bin from the cabinet.
- Place plastic waste liner around the basket (2 waste liners included).
Allow bag edges to overhang.
- Slide the waste bin into the cabinet and shut the cabinet door.
- Store this operation manual in slot inside cabinet door.

Switching "ON"

- Toggle the power switch ON.

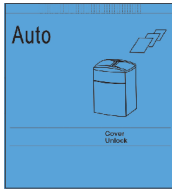

- The LCD panel indicates machine is ready for shredding operation.

Note: The display indication is always shown for unlocked paper tray doors.

Load and Shred



Open doors

Place up to the maximum number of sheets of paper into the paper tray.



Close doors

Press "START" button.

When the shred job is complete, the machine will automatically stop.

Operation (cont'd)



To manually feed paper (max. 6 sheets) or lubricant sheets.

- The shredding process is initiated by photo sensors in the paper feed opening. Insert a maximum of 6 sheets of paper into the paper feed opening; shredding begins automatically. When shredding is complete, the cutting system automatically stops after approximately 3 seconds.
- For maintenance, shredder lubricant sheets should be fed in the paper feed opening as well.



To clear paper jam.

- If paper jam occurs press and hold the "Reverse" button to back paper out of the paper entry. Try pulling gently on the paper to remove it from the shredder. Alternate between forward and reverse, as needed, until the jam clears.
- On LCD, REVERSE will be displayed.

Operation (cont'd)

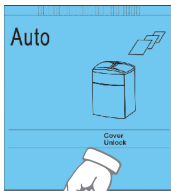

AUTO Mode

- The master power switch is located on the top right side of the cabinet. When switch is toggled ON, the LCD shows AUTO and the machine enters into AUTO mode.
- In the AUTO mode, the shredder is ready to shred paper either by auto or manual feed.

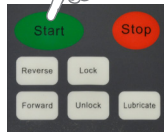

START Mode

- Press the "Start" button and the machine starts shredding paper loaded in paper tray. The LCD shows AUTO with paper feeding.

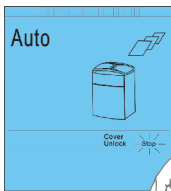

STOP Mode

- Press the "Stop" button to interrupt the shred job. The LCD displays flashing STOP.

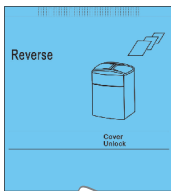

REVERSE Mode (In AUTO Mode)

- Pressing the "Reverse" button during AUTO Mode operation will initiate the manual REVERSE function. The LCD shows REVERSE. Press and hold the "Reverse" button in order to keep the motor running in reverse. When the "Reverse" button is released, the machine returns to AUTO mode and the display will show AUTO.



REVERSE Mode (In STOP Mode)

- When pressing the "Reverse" button during STOP Mode, the LCD shows REVERSE and the motor enters the REVERSE mode. Press and hold the "Reverse" button in order to keep the motor running in reverse. When the "Reverse" button is released, the machine returns to STOP Mode and the LCD displays flashing STOP.

NOTE: Manual reverse function will not work unless tray doors are closed.

Locking for Secure Shredding

The doors can be locked to avoid confidential papers from being taken out of the paper tray by other people.

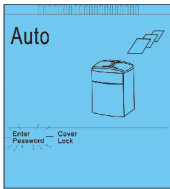

To LOCK a shred job.

- Press "Lock" button. ENTER PASSWORD will flash on LCD. Enter any 4-digit PIN. Be sure to remember the PIN. Press "Enter" button.
- COVER UNLOCK will change to COVER LOCK on the LCD.
- Both doors will be locked mechanically. The locking process takes approximately 3 seconds. After the locking process is completed, flashing COVER LOCK on LCD becomes steady.
- If the locking process cannot be completed within 7 seconds the locking process is cancelled.



To UNLOCK a secured shred job in process.

- Press "Unlock" button. ENTER PASSWORD will flash on LCD. Enter the 4-digit PIN. The code is displayed. Press "Enter" button. (In case the PIN has been forgotten, use the key supplied to UNLOCK on the right side of shredder.)
- COVER LOCK will change to COVER UNLOCK on the LCD.
- Both doors will be unlocked mechanically. The unlocking process takes approximately 3 seconds. After the unlocking process is completed, flashing COVER UNLOCK on LCD becomes steady.

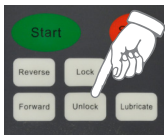
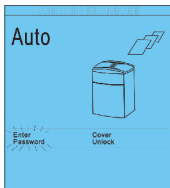

NOTE: The paper tray doors will automatically UNLOCK once the shred job has been completed.



To CANCEL password.

- If the locking or unlocking process needs to be interrupted, press "Cancel" button. The locking or unlocking process will be cancelled.
- If the input of any password digits is wrong during the Locking or Unlocking process, press "Lock" or "Unlock" button. The password is reset again.



To manually STOP a shred job.

- Press "STOP" button.

To power OFF the shredder.

- Toggle OFF the power switch. Power switch is on the top of the machine.

NOTE: Energy-Saving Technology — The R5700 will automatically toggle OFF if idle for 30 minutes. To resume power just toggle switch back ON.

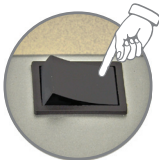

InfoCenter™ LCD Panel

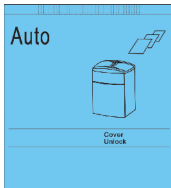

FORWARD Mode

- Pressing the "Forward" button during STOP mode will initiate the manual Forward function. Press and hold the "Forward" button in order to keep the motor running in forward. When the "Forward" button is released, the machine returns to STOP mode and the LCD displays flashing STOP.

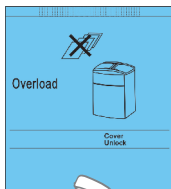

OVERLOAD Mode

- If the shredder becomes overloaded during operation, the motor will stop running and sound an alert. The LCD will display OVERLOAD. Pressing the "Reverse" button will start the motor reversing and the LCD will show REVERSE.

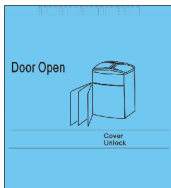

DOOR OPEN Mode

- When the cabinet door is opened while shredding, the motor will stop immediately. The LCD shows DOOR OPEN and will sound an alert. To resume normal function, the cabinet door must be closed. The LCD will show AUTO again. Press "Start" to resume normal operation.

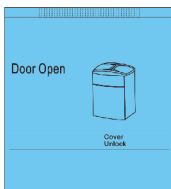

PAPER TRAY DOOR OPEN Mode

- When the paper tray doors are opened while shredding, the motor will stop immediately. The LCD shows DOOR OPEN and will sound an alert. To resume normal operation, the doors must be closed. The LCD will show AUTO again.

InfoCenter™ LCD Panel (cont'd)

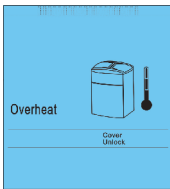

OVERHEAT Mode

- If the shredder overheats, the LCD will show a flashing OVERHEAT icon. All functions will stop. When the shredder overheats, user may press Stop button to place the shredder in Standby mode. The shredder will not resume normal functioning until the temperature of the motor cools down to a safe temperature and LCD shows AUTO.

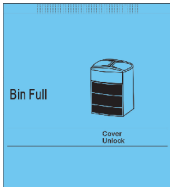

BIN FULL Mode

- If the waste bin is full, the motor will stop and sound an alert. LCD shows the character BIN FULL. All shredder functions will stop. After the waste bin is emptied, placed back into cabinet and the cabinet door is closed, the LCD will show AUTO and resume normal functioning.

ParticleSweeper™

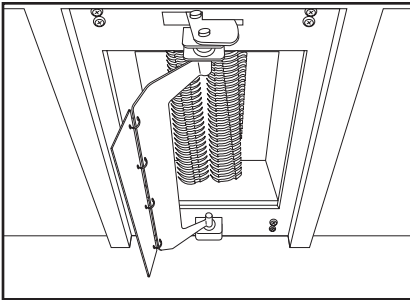

WASTE LEVELER

- The ParticleSweeper™ located under the cutting mechanism (right above the waste bin) increases bin capacity by evenly distributing and leveling shred particles.

Maintenance

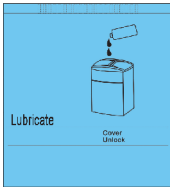

LUBRICATION

- After about one hour of accumulated shredder usage, the LCD will display "LUBRICATE". This indicates that the shredding blades need to be lubricated using an approved shredder lubricant. Only shredder lubricant sheets or bottled lubricant designed specifically for shredders should be used. Follow the instructions provided with the shredder lubricant. **NEVER USE AN AEROSOL LUBRICANT**, or any lubricant that is flammable. Refer to the warnings provided in this shredder manual.

NOTE: The shredder will continue to operate normally even while the warning icon is flashing.

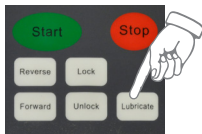

RESET LUBRICATE ALERT: After applying lubricant to the cutting blades, the warning icon can be reset by pressing and holding the "Lubricate" button for approximately 7 seconds. The LCD will clear the warning message and icon.



CLEANING RUBBER ROLLERS

CAUTION:

Before proceeding with the next step, **PLEASE POWER DOWN THE SHREDDER AND UNPLUG THE SHREDDER FROM THE OUTLET.**

- After the shredding blades have been lubricated, we recommend cleaning the rubber rollers with rubbing alcohol. Apply the rubbing alcohol to a clean, dry cloth and briskly clean each roller.
- Manually rotate the rollers and continue to clean until no contaminants appear on the cloth.
- After rollers are clean, let the rollers dry for approximately 5 minutes.
- The Boxis™ AutoShred™ is now ready. Reconnect power to the machine and operate.

Warranty and Product Registration

The manufacturer warrants the machine for a limited time to be free from defects in material and workmanship, does NOT include normal wear and tear. If any part is found to be defective during the warranty period, your sole and exclusive remedy will be repair or replacement, at the manufacturer's option and expense, of the defective part except for the postage. It is the responsibility of the consumer to return the machine to the manufacturer.

This warranty is valid for the original consumer only with original proof of purchase and is not transferable. This warranty does not apply in cases of abuse, mishandling or unauthorized repair. ANY IMPLIED WARRANTY, INCLUDING THAT OF MERCHANTABILITY OR FITNESS FOR A PARTICULAR PURPOSE, IS HEREBY LIMITED IN DURATION TO THE APPROPRIATE WARRANTY PERIOD SET FORTH ABOVE. In no event shall the manufacturer be liable for any consequential or incidental damages attributable to this product. This warranty gives you specific legal rights. You may have other legal rights that vary.

Repairs must be performed by the manufacturer's authorized technician. For more details, or to obtain service under this warranty, please contact us at 866-707-1854.

Please retain original proof of purchase to ensure that your product is recorded and warranty information received.

Return Instructions:

Call 866-707-1854 for a Return Authorization Number (RA#) in order to return a defective product.

Product Registration:

Please register your new product by calling 866-707-1854.

Contact Us:

For more information, please call 866-707-1854, or email us at support@boxisautoshred.com.



“

*Our commitment to revolutionizing productivity in our area
of expertise will help you be an expert in yours.*

”

boxis™
autoshred

A REVOLUTION IN PRODUCTIVITY

Toll-Free 866.707.1854 | www.boxisautoshred.com

An INTEK Brand | We Care. We Share. ©2012 INTEK America Inc.
18528 S. Dominguez Hills Drive, Rancho Dominguez, CA 90220