

DOREL ASIA

Sectional sofa

Model No: WM3508

UPC CODE:
0-65857-15548-8

NOTE:
THIS INSTRUCTION BOOKLET
CONTAINS **IMPORTANT** SAFETY
INFORMATION. PLEASE READ AND
KEEP FOR FUTURE REFERENCE.

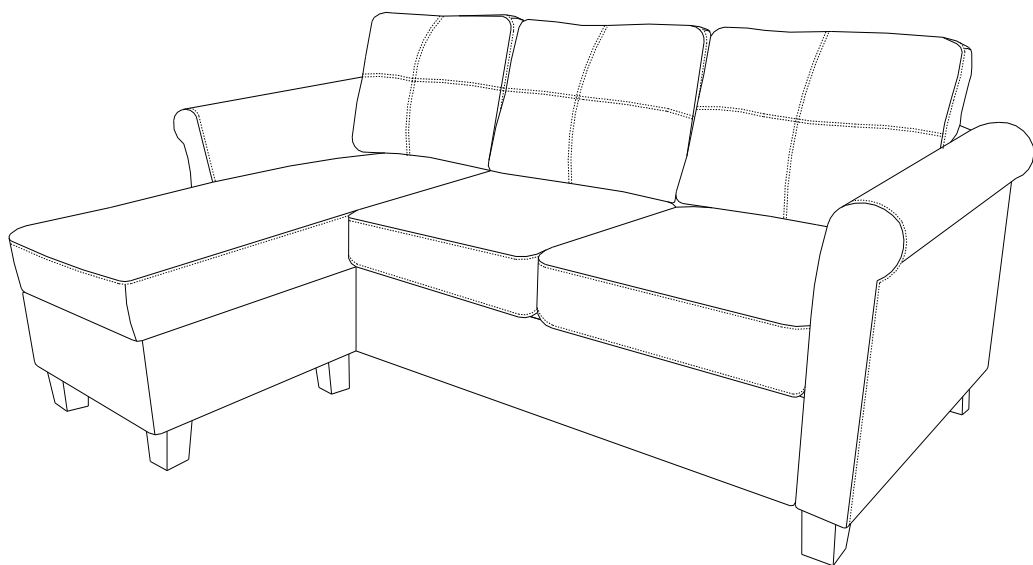

Lot number:
(TAKEN FROM CARTON)

Date of purchase:

____ / ____ / ____

DO NOT RETURN PRODUCT TO THE STORE.

If a part is missing or damaged, contact our
customer service department. We will replace the part
FREE of charge.



Tel #: 1-800-295-1980
E-Mail: das@dorel.com
Fax #: 514-353-7819

CUSTOMER SERVICE

If you have any questions about this product, contact our customer service representative.

 **CALL 1-800-295-1980**

**Customer Service Department No. 413
12345 Albert-Hudon Boulevard, Suite 100
Montreal, Quebec
Canada H1G 3L1**

E-MAIL: das@dorel.com

NOTES

- * Ensure all parts and components are present before beginning assembly.
- * Assemble on soft, smooth surface to prevent damage to product finish.
- * **DO NOT** use power tools.
- * **CAUTION:** Adult assembly required.
- * Assembly and handling will require two people.
- * Estimated assembly time: 8 minutes.

CARE AND CLEANING

Wipe away spills immediately to prevent staining. Use a cloth dampened with water or a professional product to clean the fabric. Always test an inconspicuous area first. Allow upholstery to dry and brush lightly. Keep away from heat to avoid glazing, melting or scorching.

MAINTENANCE

Check bolts/screws periodically and tighten them if necessary.

DOREL ASIA LIMITED WARRANTY

Dorel Asia warrants its product to be free from defects in material and workmanship and agrees to remedy any such defect. This warranty covers 1 year from the date of original purchase. This warranty is valid only upon presentation of proof of purchase. This is solely limited to the repair or replacement of defective furniture components and no assembly labor is included. This warranty does not apply to any product which has been improperly assembled, subjected to misuse or abuse or which has been altered or repaired in any way. This warranty gives you specific legal rights and you may also have other rights which vary from State to State.



WARNING: Should this product become damaged, and/or components are broken or missing, DO NOT USE.

Sectional Sofa WM3508

HARDWARE LIST

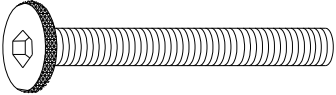
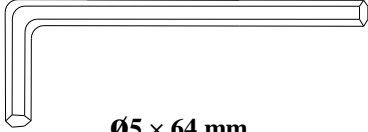
| | |
|--|--|
| 1 | 2 |
|  <p>$\text{Ø}5/16'' \times 100 \text{ mm}$</p> |  <p>$\text{Ø}5 \times 64 \text{ mm}$</p> |
| HEX SOCKET HEAD BOLT 8 PCS | ALLEN KEY 1 PC |

PARTS LIST

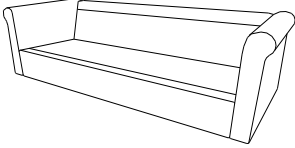
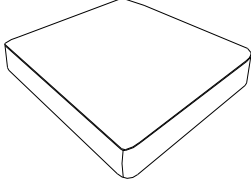
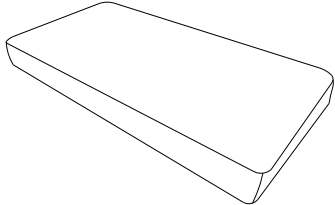
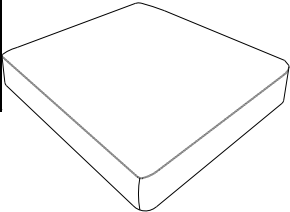
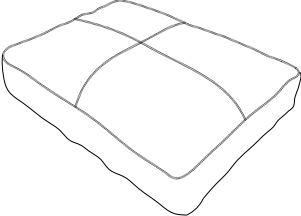
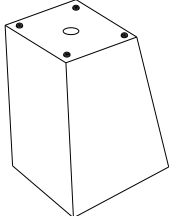
| | | |
|---|---|---|
| A | B | C |
|  |  |  |
| SOFA BODY 1 PC | OTTOMAN 1 PC | LONG SEAT CUSHION 1 PC |
| D | E | F |
|  |  |  |
| SEAT CUSHION 2 PCS | BACK CUSHION 3 PCS | FOOT 8 PCS |

Sectional Sofa WM3508

STEP 1:

With the help of another person, gently lay the sofa body (A) upside down on a clean smooth surface. Back cushions (E) have been packaged underneath the sofa body (A). Gently pull back the lining off the velcro strips to remove back cushions (E).

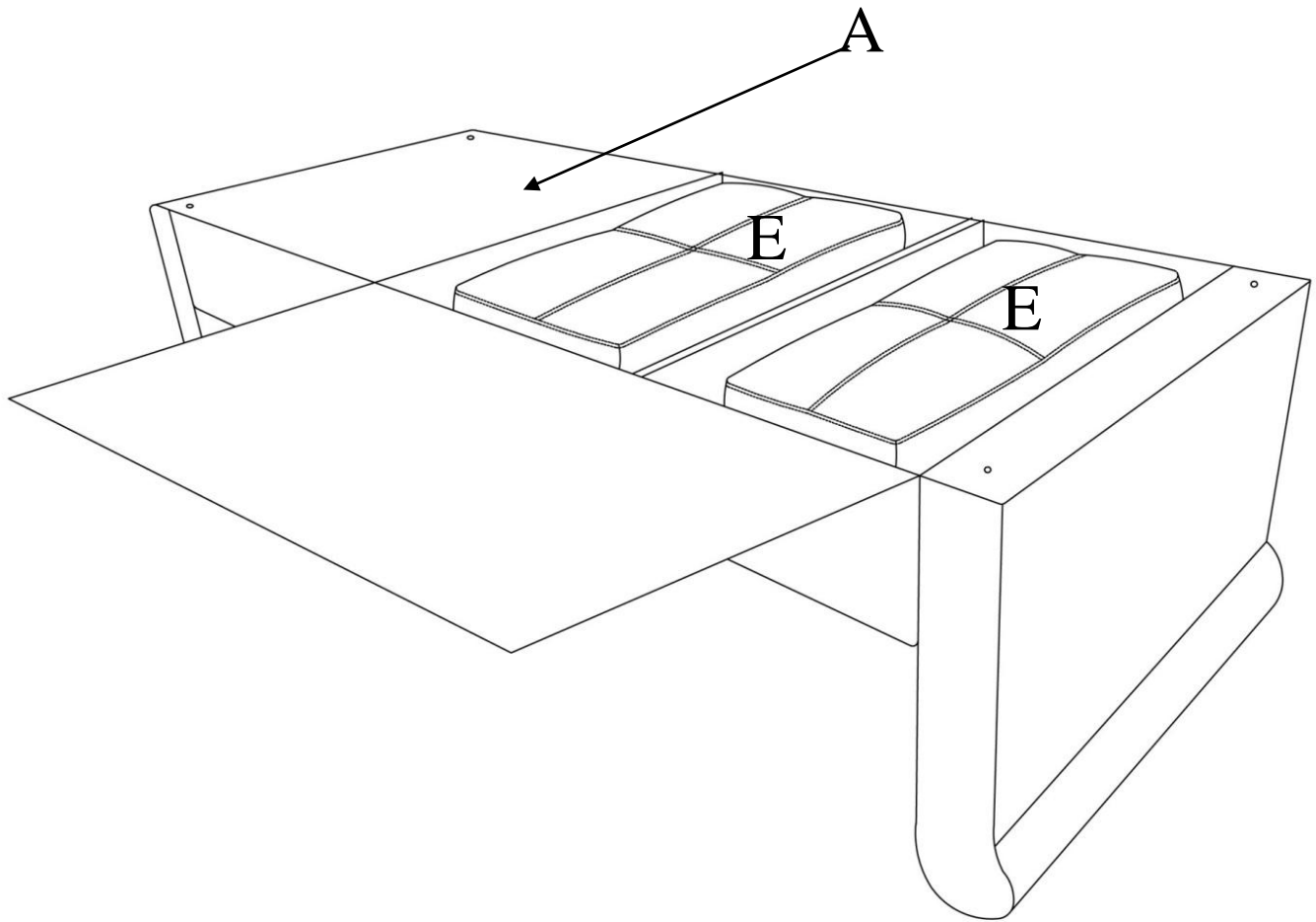

Sectional Sofa WM3508

STEP 2:

Screw feet (F) into the ottoman (B) and sofa body (A) with hex socket head bolts (1). Use Allen key (2) to tighten the bolts.

Turn the sofa body (A) and ottoman (B) upright.

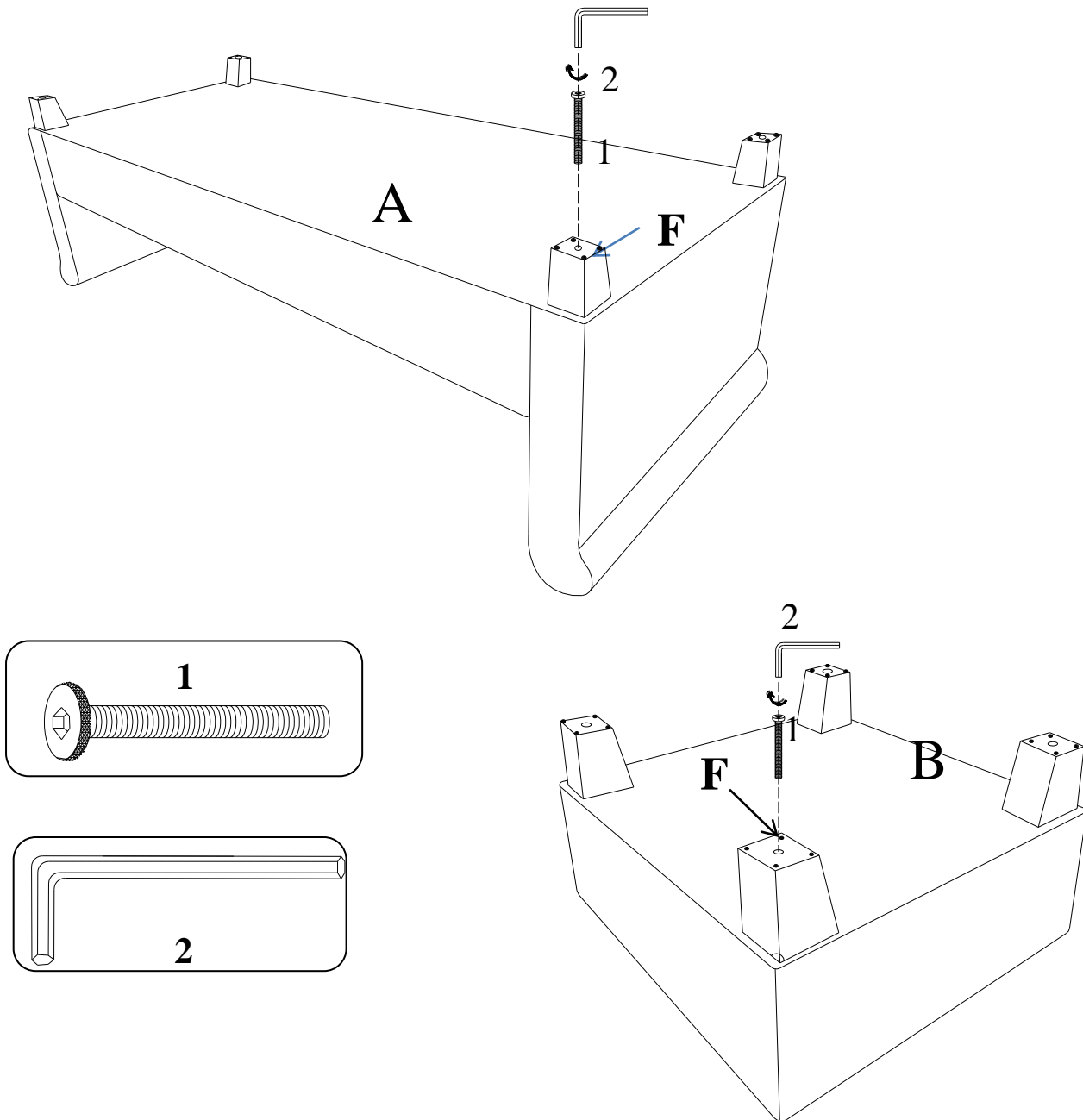

Sectional Sofa WM3508

STEP 3:

Place back cushions (E), seat cushions (D) and long seat cushion (C) on the sectional.

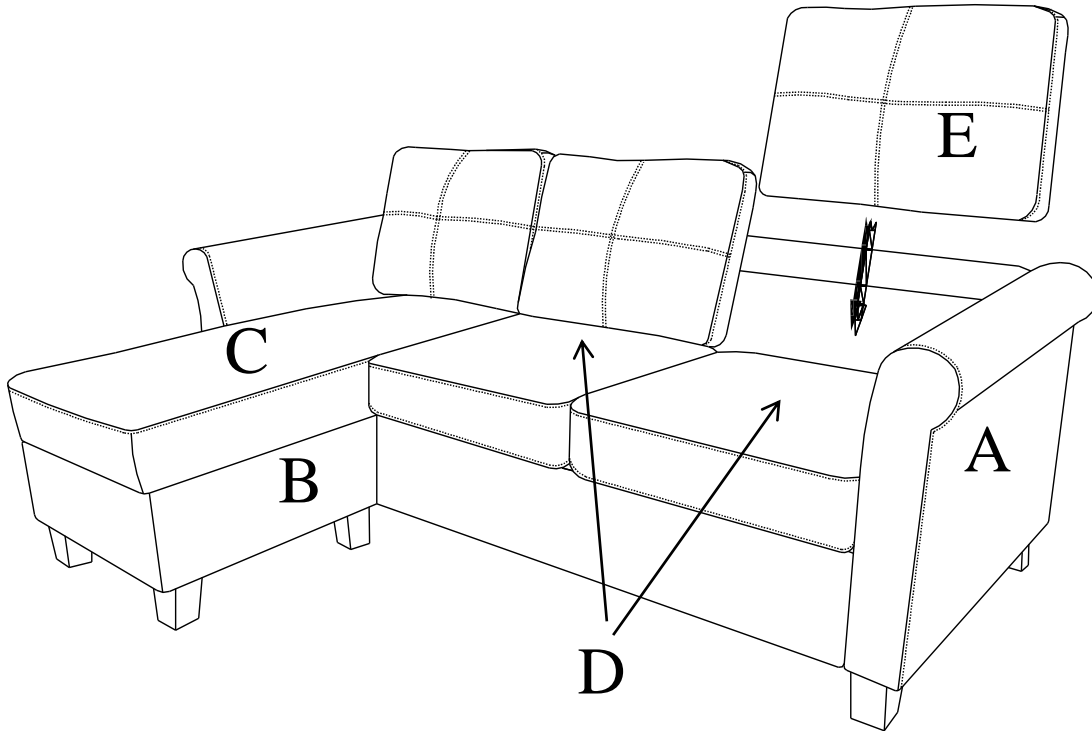

NOTE:

Ottoman (B) can be placed on either the left or right side of the sofa main body.

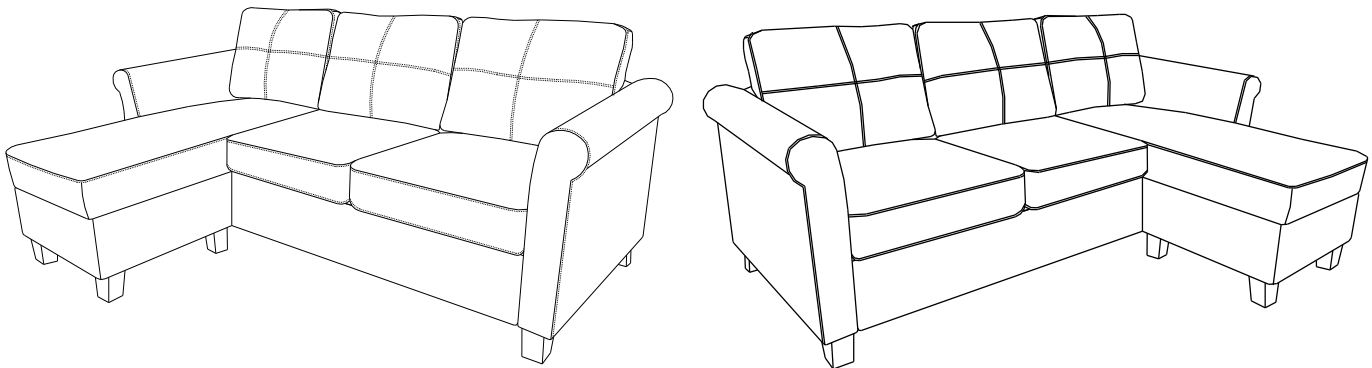

Sectional Sofa WM3508



CAUTION: This unit is intended for use only with the products and/or maximum weights indicated. Use with other products and/or products heavier than the maximum weights indicated may result in instability or cause possible injury.

Wipe away spills immediately to prevent staining. Use a cloth dampened with water or a professional product to clean the fabric. Always test an inconspicuous area first. Allow upholstery to dry and brush lightly. Keep away from heat to avoid glazing, melting or scorching.

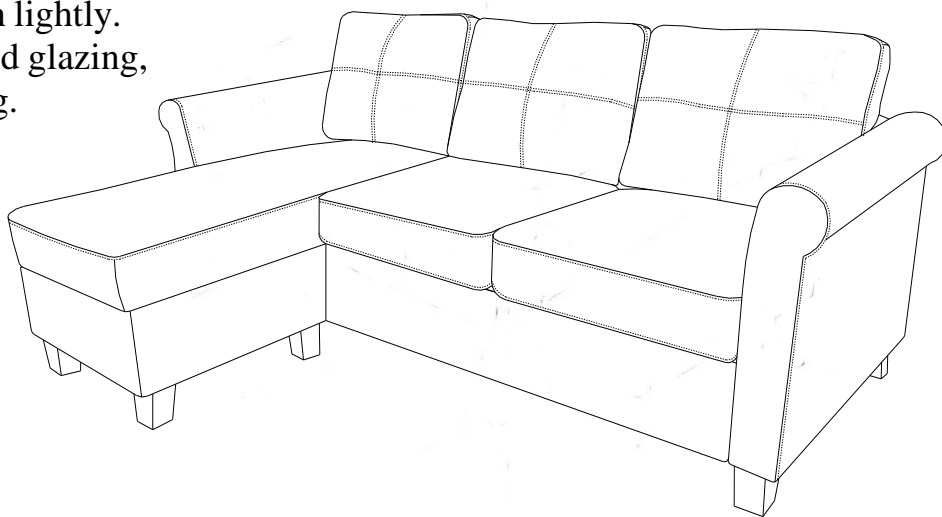

That's it ! You've finished assembling your sectional sofa.

DO NOT RETURN PRODUCT TO THE STORE.

If a part is missing or damaged, contact our customer service department. We will replace the part **FREE** of charge.



Tel #: 1-800-295-1980
E-Mail: das@dorel.com
Fax #: 514-353-7819

Customer Service

PLEASE DO NOT RETURN THIS PRODUCT TO THE STORE

PLEASE CONTACT CUSTOMER SERVICE REPRESENTATIVES AT THE FOLLOWING NUMBERS SHOULD THERE BE ANY MISSING OR DEFECTIVE PART(S).

| | |
|--|---|
| Customer Service Phone Number 1-800-295-1980 | Email: das@dorel.com |
| Customer Service Fax Number 514-353-7819 | |

Request Date:

Name:

Shipping Address:

Street & Number:

City & State:

Zip Code:

Day Time Phone Number:

(including area code)

Date & Place of Purchase:

Part(s) description and quantity (Please be sure to list model number or SKN number):