

English

MULTI-FUNCTIONAL COMPUTER TABLE ASSEMBLY INSTRUCTION



MODEL RTA - S06

IMPORTANT: Surfaces must be cleaned with a solution of a smooth soap and water, then cleared with a dry towel. Do not use solvents over surfaces or structural tubes.

Thanks for purchasing one of our products, please read carefully the assembly instructions before the installation (Attention: Do not tighten the screws before all screws are in place).

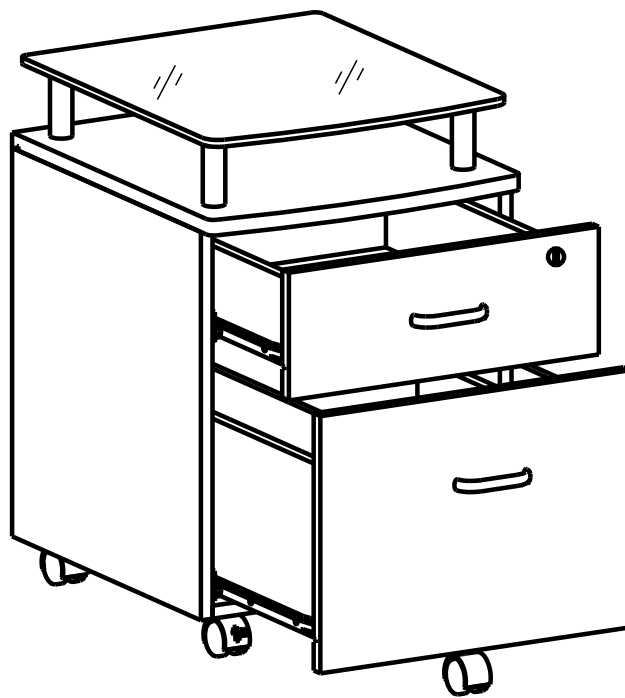

MODEL RTA-S06



Spanish

INSTRUCCIONES DE ENSAMBLAJE.

TECHNI
MOBILI

MODELO RTA-S06

IMPORTANTE: Para su limpieza sobre la superficies utilice una toalla humedecida en una solución de agua y jabón de pasta y luego pase sobre esta un trapo seco. No utilice solventes, sobre las superficie ni las estructuras tubulares.



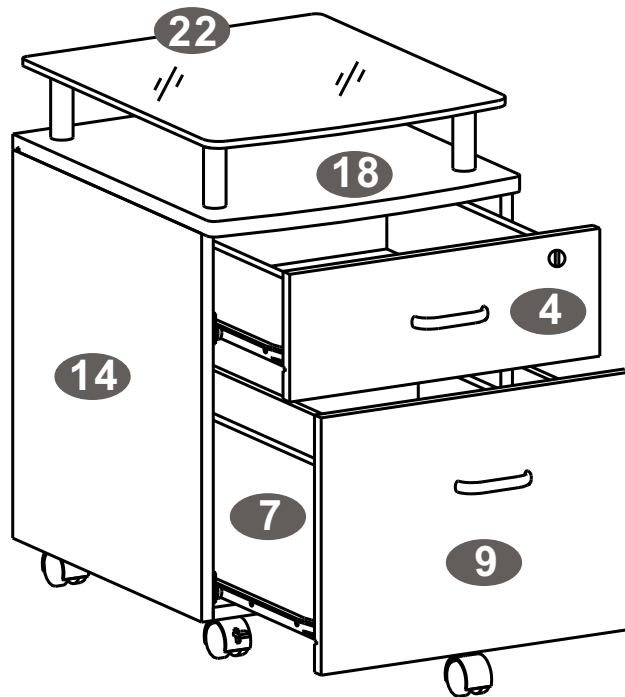

Gracias por comprar uno de nuestros productos por favor lea cuidadosamente las instrucciones de ensamblaje antes de instalar la unidad. (Atencion: No ajuste firmemente los tornillos antes de tener la estructura completamente armada).





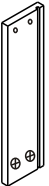
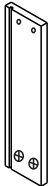
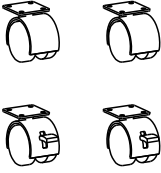
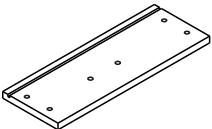
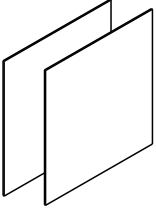
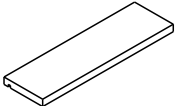

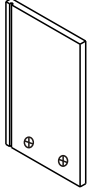
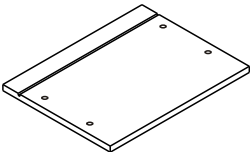
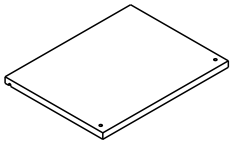
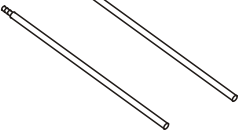
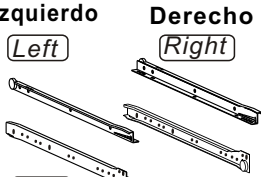

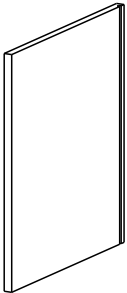
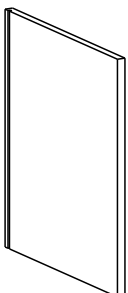
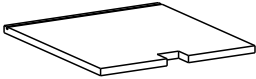
MODELO RTA-S06

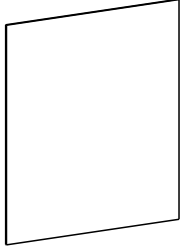

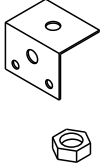



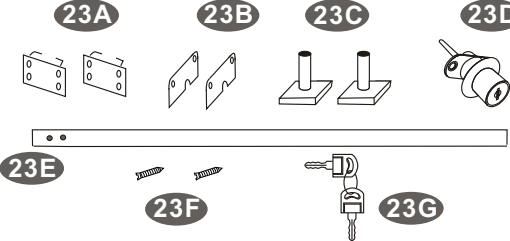

RTA
PRODUCTS • LLC

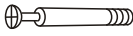
▪ PARTS LIST ▪ LISTA DE PARTES

<p>1</p>  <ul style="list-style-type: none"> ▪ Top Drawer Left Panel ▪ Panel Izquierdo de Gaveta Superior 	<p>2</p>  <ul style="list-style-type: none"> ▪ Top Drawer Right Panel ▪ Panel Derecho de Gaveta Superior 	<p>3</p>  <ul style="list-style-type: none"> ▪ Casters ▪ Ruedas 	<p>4</p>  <ul style="list-style-type: none"> ▪ Top Drawer Front Panel ▪ Panel Frontal de Gaveta Superior
<p>5</p>  <ul style="list-style-type: none"> ▪ Drawer Bottom Panel ▪ Panel Inferior de Gaveta 	<p>6</p>  <ul style="list-style-type: none"> ▪ Top Drawer Back Panel ▪ Panel Posterior de Gaveta Superior 	<p>7</p>  <ul style="list-style-type: none"> ▪ Bottom Drawer Left Panel ▪ Panel Izquierdo de Gaveta Inferior 	<p>8</p>  <ul style="list-style-type: none"> ▪ Bottom Drawer Right Panel ▪ Panel Derecho de Gaveta Inferior
<p>9</p>  <ul style="list-style-type: none"> ▪ Bottom Drawer Front Panel ▪ Panel Frontal de Gaveta Inferior 	<p>10</p>  <ul style="list-style-type: none"> ▪ Bottom Drawer Back Panel ▪ Panel Posterior de Gaveta Inferior 	<p>11</p>  <ul style="list-style-type: none"> ▪ Tubes for Files ▪ Tubos para los Archivos 	<p>12</p>  <p>Izquierdo (Left) Derecho (Right)</p> <p>Izquierdo (Left) Derecho (Right)</p> <p>2pcs</p> <ul style="list-style-type: none"> ▪ Sliders ▪ Deslizadores
<p>13</p>  <ul style="list-style-type: none"> ▪ Handles ▪ Manijas 	<p>14</p>  <ul style="list-style-type: none"> ▪ Left Panel ▪ Panel Izquierdo 	<p>15</p>  <ul style="list-style-type: none"> ▪ Right Panel ▪ Panel Derecho 	<p>16</p>  <ul style="list-style-type: none"> ▪ Bottom Panel ▪ Panel Inferior

<p>17</p>  <ul style="list-style-type: none"> ▪ Back Panel ▪ Panel Posterior 	<p>18</p>  <ul style="list-style-type: none"> ▪ Top Panel ▪ Panel Superior 	<p>19</p>  <ul style="list-style-type: none"> ▪ L Bracket ▪ Angulo de Soporte 	<p>20</p>  <ul style="list-style-type: none"> ▪ Front Wheel ▪ Rueda Frontal
<p>21</p>  <ul style="list-style-type: none"> ▪ Support Tubes ▪ Tubos de Soporte 	<p>22</p>  <ul style="list-style-type: none"> ▪ Top Glass Panel ▪ Vidrio del Panel Superior 	<p>23A 23B 23C 23D 23</p>  <ul style="list-style-type: none"> ▪ A,B,C-Metal Fittings; D-Lock; E-Metal Plate; F-Screws; G-Key ▪ A,B,C-Accesorios de Metal; D-Cerradura; E-Placa de Metal; G-Llave 	

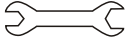
▪ SCREWS ▪ TORNILLOS

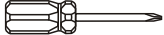
PART	QTY.	ITEM		PART	QTY.	ITEM	
A	16	6X40 MM		F	1	6X12 MM	
B	8	4X30 MM		G	4	6X20 MM	
C	30	3X15 MM		H	4	6X25 MM	
D	4	4X20 MM			1		
E	18	4X14 MM			1		

▪ **6X40MM BOLT INSTALLATION AS BELOW:**

▪ **6x40mm INSTALE EL PERNO ASI:**

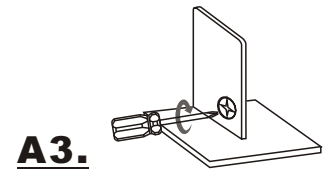
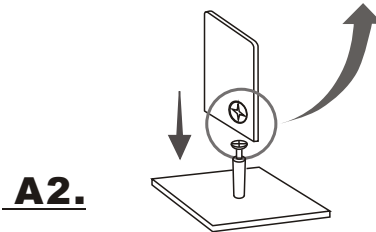
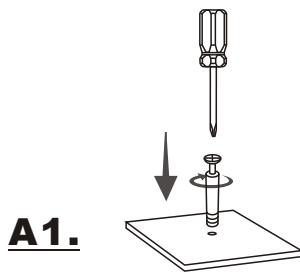
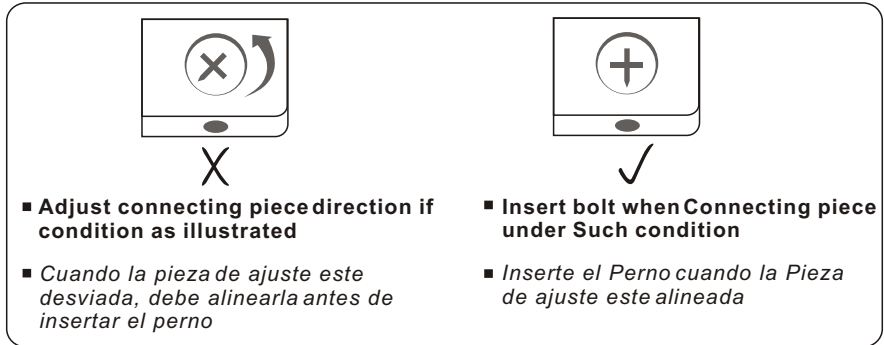
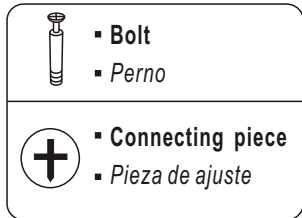

▪ **STEPS**

▪ **PASOS**

1

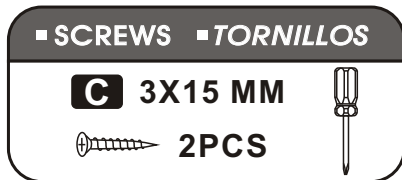
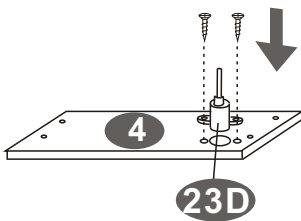

- Use screws C to fix the Lock (23D) to the back face of Top Drawer Front Panel (4).
- Use tornillos C para fijar la cerradura (23D) en la cara posterior del Panel Frontal de Gaveta Superior (4)

2

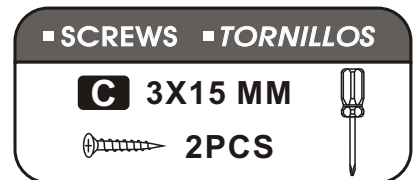
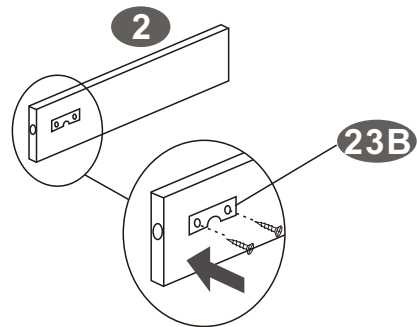

- Use screws C to assemble the Metal Fitting (23B) to the Top Drawer Right Panel (2).
- Use tornillos C para ensamblar el Accesorio de Metal (23B) al Panel Derecho de la Gaveta Superior (2).

3

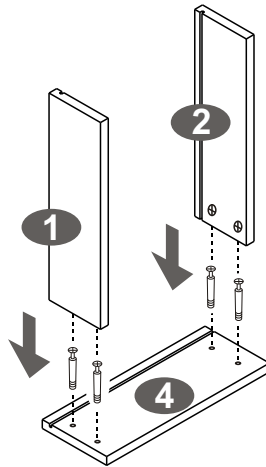

■ SCREWS ■ TORNILLOS

A 6X40 MM

4PCS



- Insert the Bolts A in the holes of the back face of the Top Drawer Front Panel (4) and tighten them with the screwdriver, then place the Top Drawer Left Panel (1) and the Top Drawer Right Panel (2) over the Bolts and tighten the nuts on the inside face.

- Inserte los Pernos A en los agujeros de la cara posterior del Panel Frontal de Gaveta Superior (4) y ajústelos con el destornillador, luego coloque sobre ellos el Panel Izquierdo de Gaveta Superior (1) y el Panel Derecho de Gaveta Superior (2) y ajuste las tuercas situadas en la cara interna de los Paneles.

4

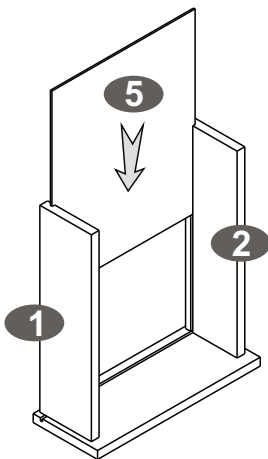

- Slide in the Drawer Bottom Panel (5).
- Deslice el Panel Inferior de Gaveta (5).

5

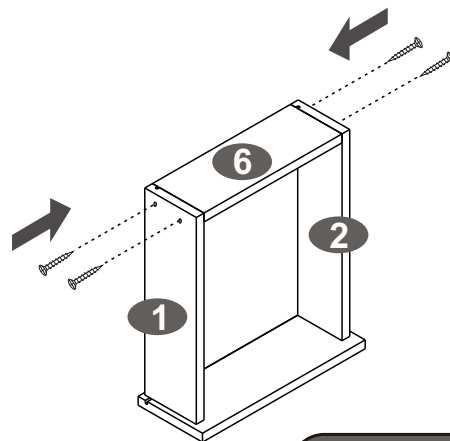

■ SCREWS ■ TORNILLOS

B 4X30 MM

4PCS



- Use Screws B to fix the Top Drawer Back Panel (6) to the Top Drawer's Left and Right Panels (1 & 2).
- Use tornillos B para fijar el Panel Posterior de Gaveta Superior (6) a los Paneles Izquierdo y Derecho de Gaveta Superior (1 y 2).

6

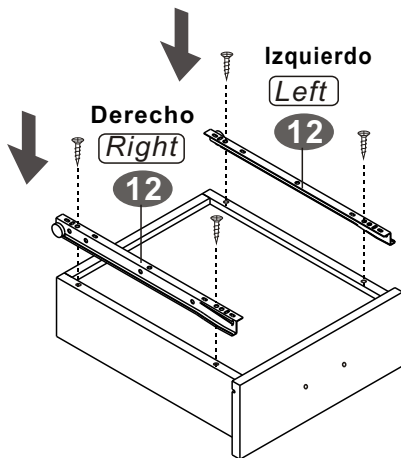

- Align selected holes on slides as illustrated with pre-drilled holes on drawer box before inserting screws
- Haga coincidir los agujeros seleccionados en los Deslizadores con los agujeros pre-taladrados sobre el cajón de la gaveta (como indica la ilustración) antes de insertar los tornillos.

▪ SCREWS ▪ TORNILLOS

C 3X15 MM

4PCS



- Use screws C to assemble the Slider (12) to the Top Drawer Left & Right Panels (1 & 2).
- Use tornillos C para ensamblar los Deslizadores (12) a los Paneles Izquierdo y Derecho de Gaveta Superior (1 y 2).

7

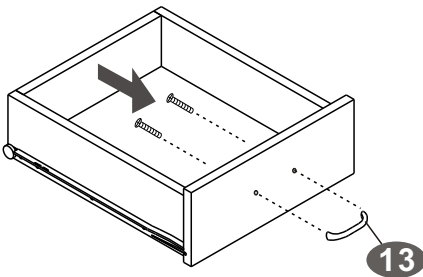

▪ SCREWS ▪ TORNILLOS

D 4X20 MM

2PCS



- Use screws D to fix the Handle (13) to the Top Drawer Front Panel (4).
- Use tornillos D para fijar la Manija (13) al Panel Frontal de Gaveta Superior (4).

8

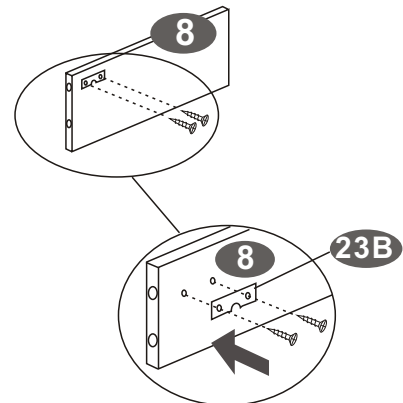

▪ SCREWS ▪ TORNILLOS

C 3X15 MM

2PCS



- Use screws C to assemble the Metal Fitting (23B) to the Bottom Drawer Right Panel (8).
- Use tornillos C para ensamblar el Accesorio de Metal (23B) al Panel Derecho de Gaveta Inferior

9

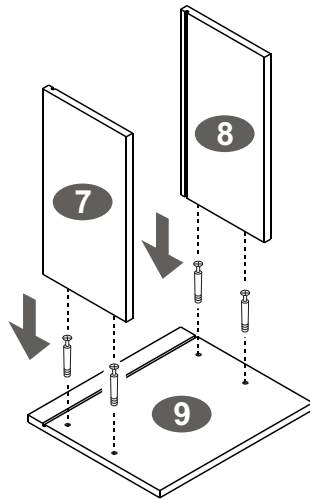

■ SCREWS ■ TORNILLOS

■ **A** 6X40 MM

■ 4PCS



- Insert the Bolts A in the holes of the back face of the Bottom Drawer Front Panel (9) and tighten them with the screwdriver, then place the Bottom Drawer Left Panel (7) and the Bottom Drawer Right Panel (8) over the Bolts and tighten the nuts on the inside faces.

- Inserte los Pernos A en los agujeros de la cara interna del Panel Frontal de Gaveta Inferior y ajústelos con el destornillador, luego coloque el Panel Izquierdo de Gaveta Inferior (7) y el Panel Derecho de Gaveta Inferior (8) sobre los pernos y ajuste las tuercas en la cara interna de los Paneles.

10

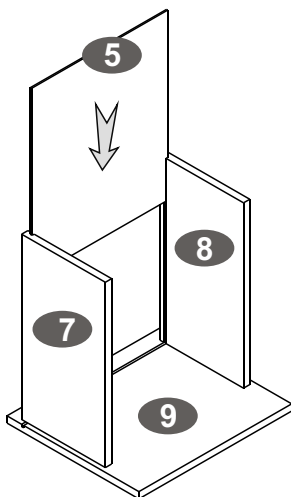

- Slide in the Drawer Bottom Panel (5).
- Deslice el Panel Inferior de Gaveta (5).

11

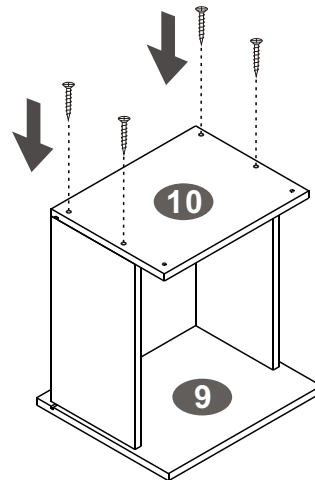

■ SCREWS ■ TORNILLOS

■ **B** 4X30 MM

■ 4PCS

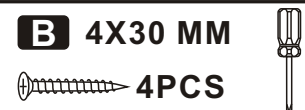

- Use Screws B to fix the Bottom Drawer Back Panel (10) to the Bottom Drawer's Left and Right Panels (7 & 8).
- Use tornillos B para fijar el Panel Posterior de Gaveta Inferior (10) a los Paneles Izquierdo y Derecho de Gaveta Inferior (7 y 8).

12

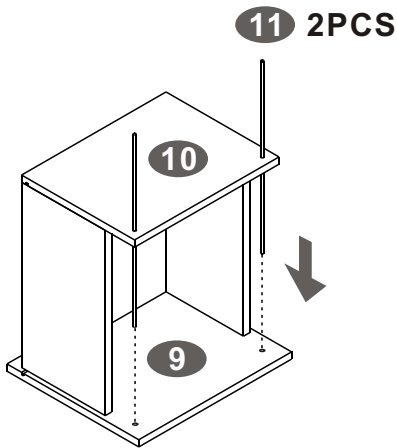

- Insert the Tubes for Files (11).
- Inserte los Tubos para los Archivos (11).

13

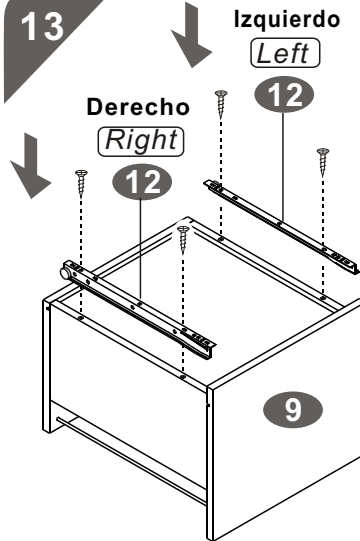

Align selected holes on slides as illustrated with pre-drilled holes on drawer box before inserting screws

Haga coincidir los agujeros seleccionados en los Deslizadores con los agujeros pre-taladrados sobre el cajón de la gaveta (como indica la ilustración) antes de insertar los tornillos.

■ SCREWS ■ TORNILLOS

C 3X15 MM

4PCS



- Use screws C to assemble the Slider (12) to the Bottom Drawer Left & Right Panels (7 & 8).
- Use tornillos C para ensamblar los Deslizadores (12) a los Paneles Izquierdo y Derecho de Gaveta Inferior (7 y 8).

14

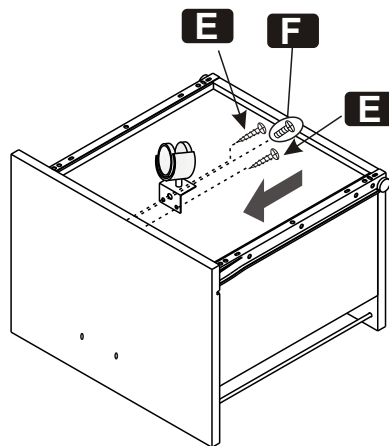
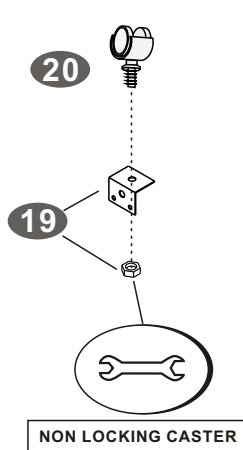

■ SCREWS ■ TORNILLOS

E 4X14 MM

2PCS



F 6X12 MM

1PC



- Fix the Front Wheel (20) to the L Bracket (19) and tighten it well. Turn around the lower drawer, Use screws E & F to assemble the L Bracket (19) to the Bottom Drawer Front Panel (9).
- Fije la Rueda Delantera (20) al Angulo de Soporte (19) y ajuste bien. Use tornillos E y F para ensamblar el Angulo de Soporte (19) al Panel Frontal de la Gaveta Inferior (9) en el lado posterior de la misma. Use una rueda sin freno.

15

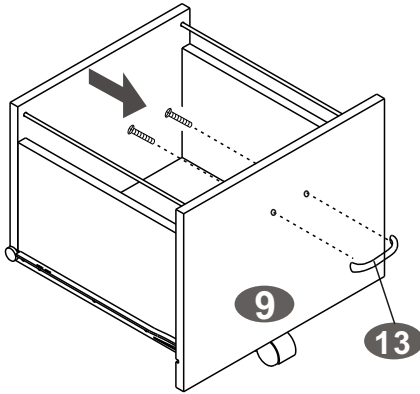

■ SCREWS ■ TORNILLOS

D 4X20 MM

2PCS



- Use screws D to fix the Handle (13) to the Bottom Drawer Front Panel (9).
- Use tornillos D para fijar la Manija (13) al Panel Frontal de Gaveta Inferior (9).

16

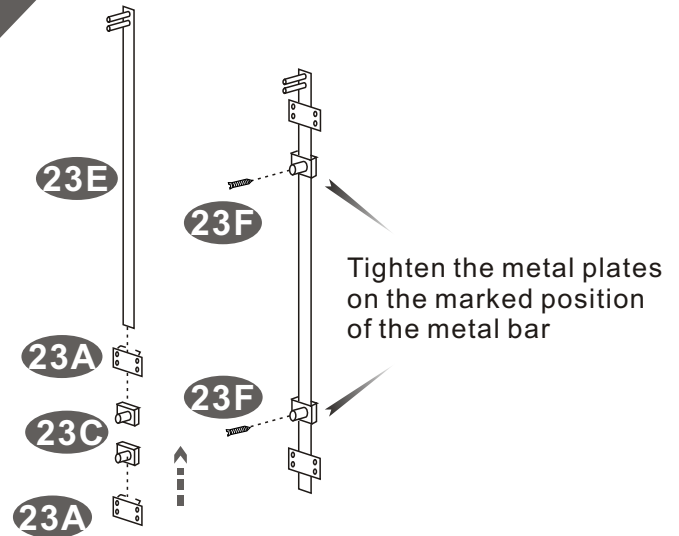

Tighten the metal plates on the marked position of the metal bar

- First Slide into the Metal Bar (23E) the 4 Metal Fittings in the order shown in the drawing (23A,23C,23C,23A). Then, tighten the metal plates 23C on the marked position of the Metal Bar (23E) with 23F.
- Apreté las Placas de Metal (23F) en la posición marcada sobre la Barra de Metal. Primero deslice en la Barra de Metal (23E) los cuatro accesorios de metal en el orden que muestra el dibujo (23A,23C,23C,23A). Luego ajuste los Accesorios de Metal (23C) en la posición marcada sobre la Barra de Metal (23E) con 23F.

17

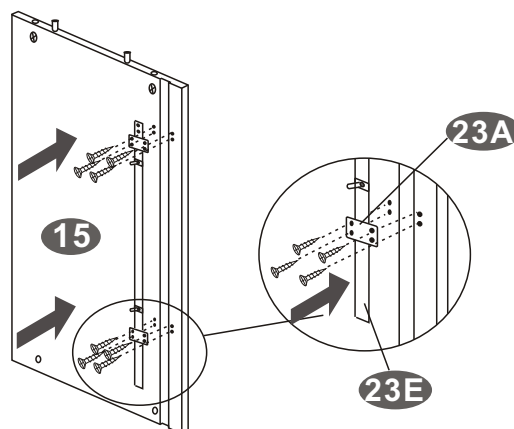

■ SCREWS ■ TORNILLOS

C 3X15 MM

8PCS



- Use screws C and the Metal Fittings (23A) to assemble the Metal Bar (23E) to the Right Panel (15).
- Use tornillos C y el Accesorio de Metal (23A) para ensamblar la Barra de Metal (23E) al Panel Derecho (15).

18

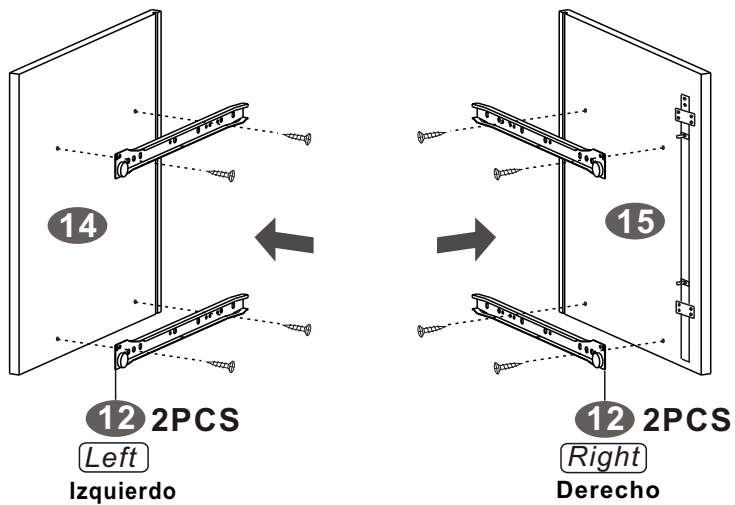

■ SCREWS ■ TORNILLOS

C 3X15 MM

8PCS



- Match the Sliders (12) with the holes of the inside faces of the Left & Right Panels (14 & 15). Then fix the fixed part to the Panels using screws C.
- Haga coincidir los Deslizadores (12) con los agujeros de la cara interna de los Paneles Izquierdo y Derecho (14 y 15). Luego fijelos a los Paneles usando tornillos C.

19

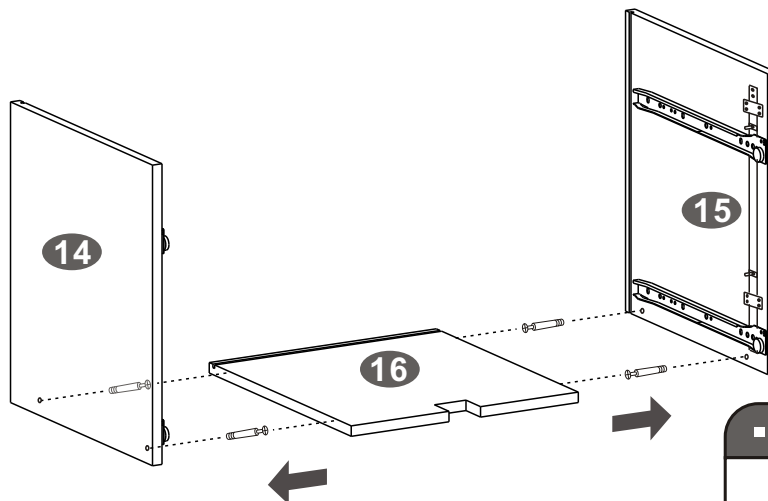

■ SCREWS ■ TORNILLOS

A 6X40 MM

4PCS



- Insert two Bolts A in the holes of the inside faces of the Left & Right Panels (14 & 15) and tighten them with the screwdriver. Place the Bottom Panel (16) over the Bolts of the Right Panel (14), then place Left Panel (15) over the Bottom Panel (16) and tighten all nuts on the inside faces of panels (16).
- Inserte los Pernos A en los agujeros de la cara interna de los Paneles Izquierdo y Derecho (14 y 15) y ajústelos con el destornillador. Coloque el Panel Inferior (16) sobre los Pernos de los Paneles Izquierdo y Derecho (14 y 15) y aprete las tuercas ubicadas en la cara interna del Panel Inferior (16).

20

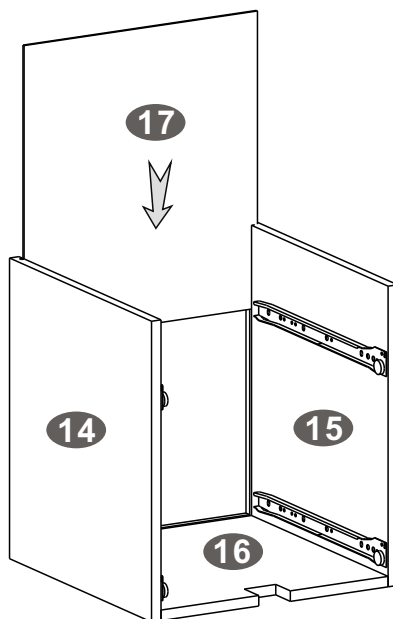

- Slide in Back Panel (17) between the Left & Right Panels (14 & 15).
- Deslice el Panel Posterior (17) entre los Paneles Izquierdo y Derecho (14 y 15).

21

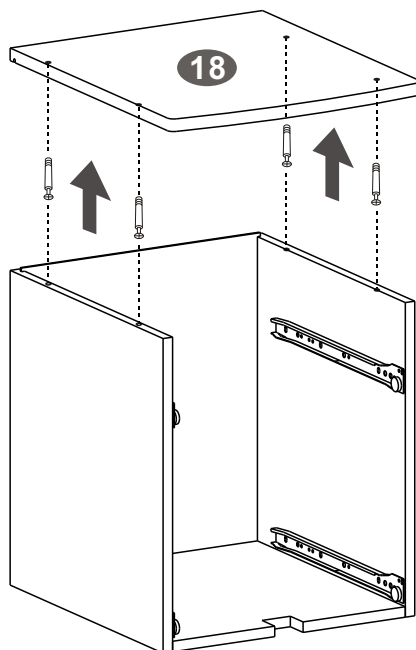

■ SCREWS ■ TORNILLOS

A 6X40 MM

4PCS



- Insert the Bolts A in the holes of the Top Panel (18) and put it over the Left & Right Panels (14 & 15) and tighten all nuts well.
- Inserte los Pernos A en los agujeros del Panel Superior (18) y coloque éste sobre los Paneles Izquierdo y Derecho (14 y 15) y ajuste bien las tuercas.

22

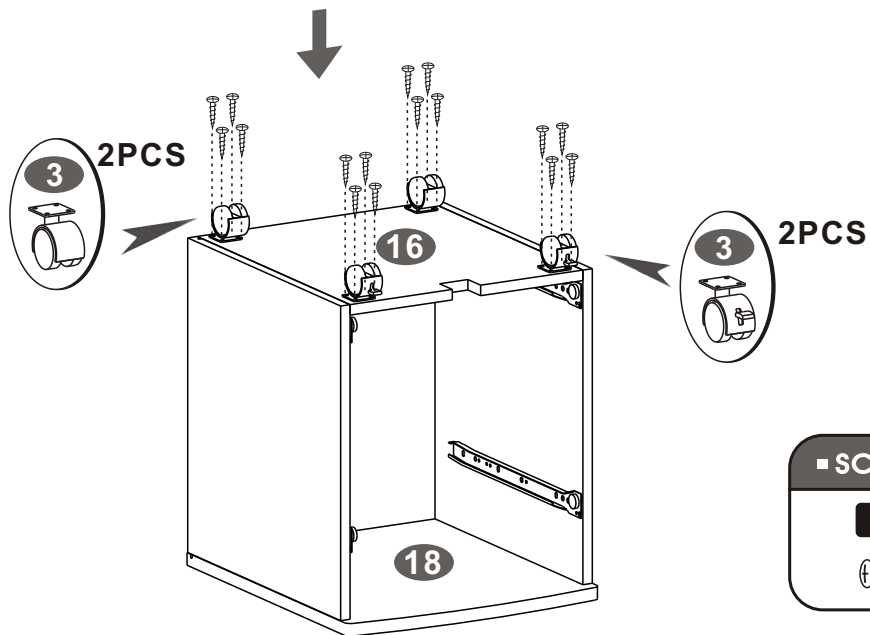

- Use screws E to fix the Casters (3) to the Bottom Panel (16).
- Use tornillos E para fijar las Ruedas (3) al Panel Inferior (16).

23

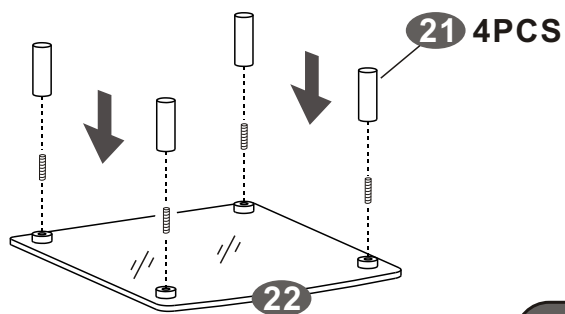

- Use screws G to assemble the Support Tubes (21) with the Top Glass Panel (22).
- Use tornillos G para ensamblar los Tubos de Soporte (21) con el Vidrio del Panel Superior (22).

24

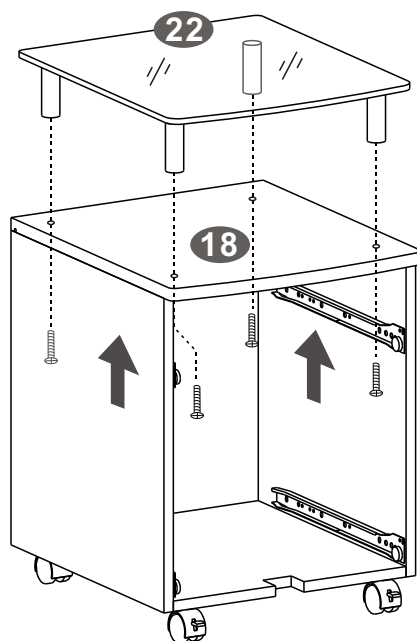

■ SCREWS ■ TORNILLOS

H 6X25 MM

4PCS



- Use screws H to assemble the Support Tubes (21) with the Top Panel (18).
- Use tornillos H para ensamblar los Tubos de Soporte (21) con el Panel Superior (18).

25

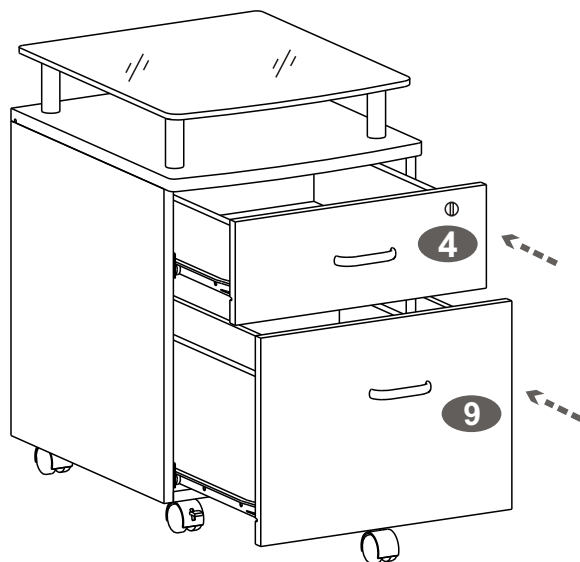

- Slide in the drawers. Tighten all screw well and enjoy the cabinet.
- Deslice las Gavetas. Ajuste bien los tornillos y disfrute su gabinete.

S-06 FILING CABINET

DIMENSIONS

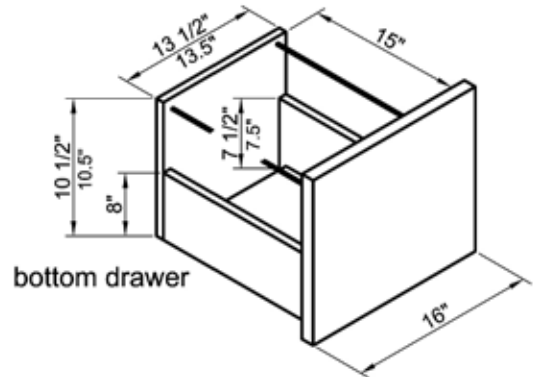
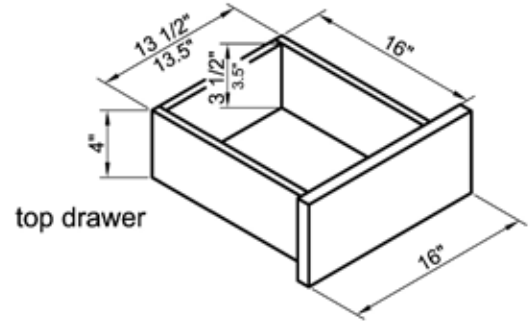
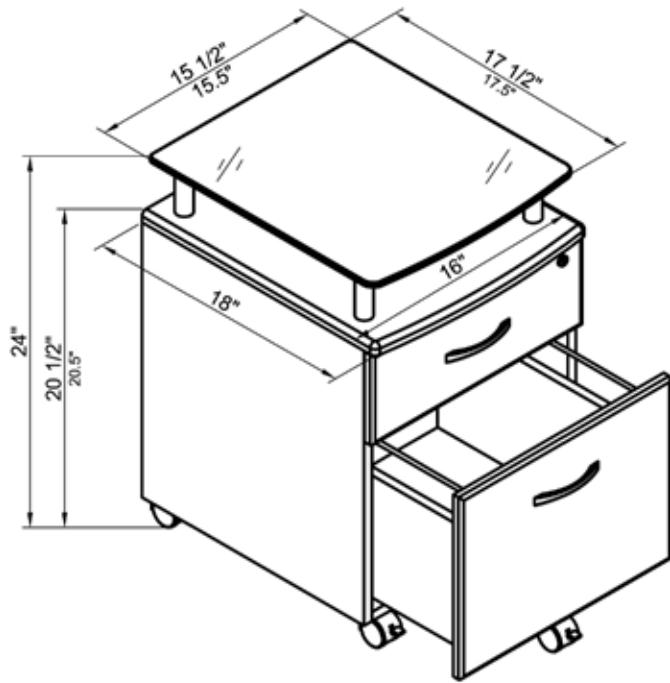

Product Size: 16"W x 18"D x 24"H

MAXIMUM WEIGHT CAPACITIES

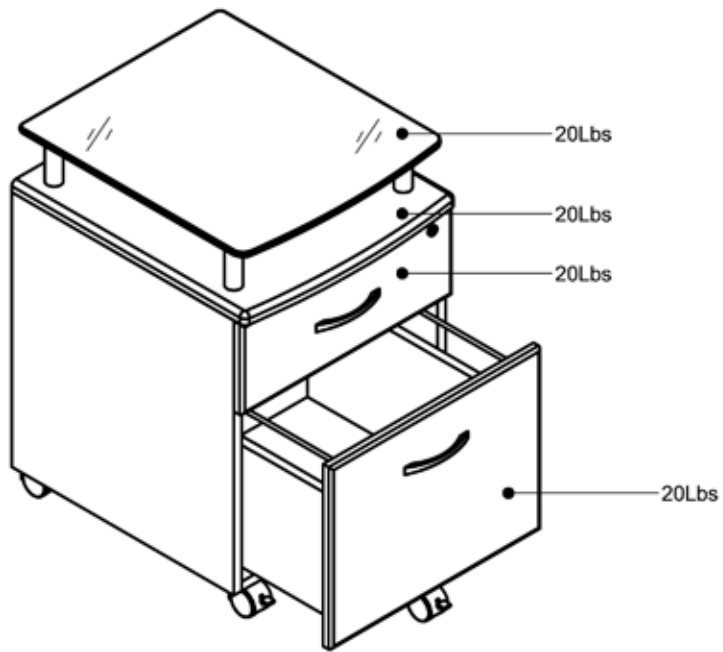

DO NOT exceed this limit
Please use care and good judgement
when placing objects on glass surface

RTA-S06 FILING CABINET

DIMENSIONS

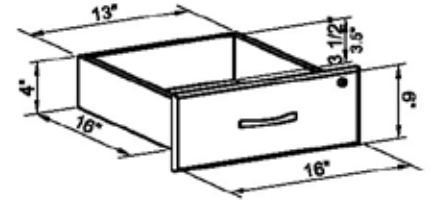
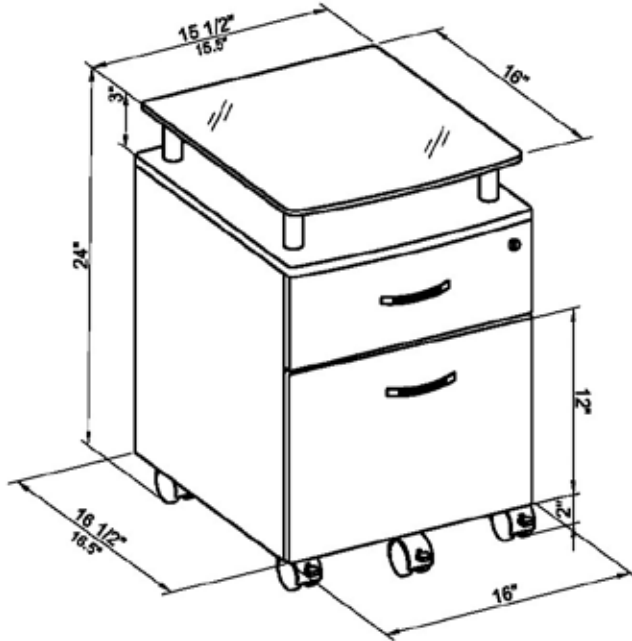

top drawer

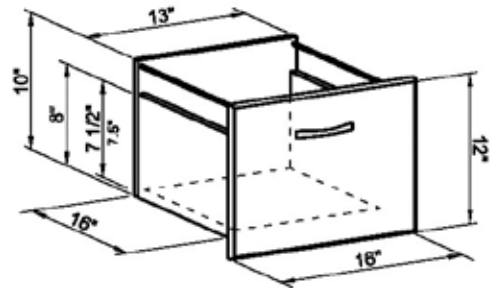

bottom drawer

Product Size: 16"W x 16 1/2"D x 24"H

MAXIMUM WEIGHT CAPACITIES

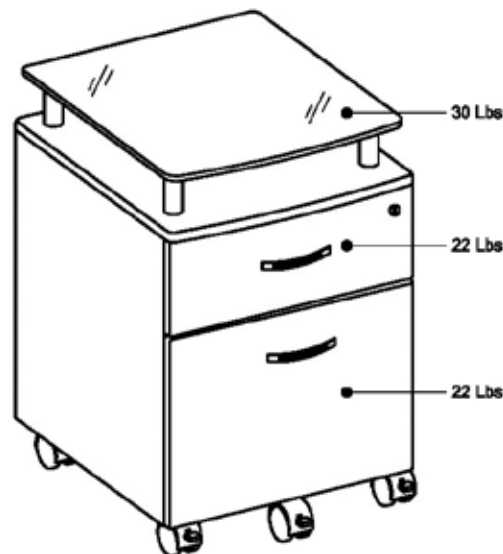

DO NOT exceed this limit
Please use care and good judgement
when placing objects on glass surface



PRODUCT WARRANTY

TECHNI MOBILI DESK WARRANTY

LIMITED 5-YEAR WARRANTY

RTA Products, LLC warrants to the Original Purchaser that this product will be free from defects in its workmanship and materials, under normal use and service conditions, as described herein. "Defects" as used in this warranty, is defined as any imperfections that impair the use of the furniture or product. RTA products will repair or replace, at its option, without charge to the original purchaser 'other than freight from purchaser to RTA Products, only the defective products or parts for a period of FIVE (5) Years.

Replacement parts can only be supplied if parts are available. Items out of production may be unavailable. This warranty will be effective for the applicable time period beginning the date of purchase on your original sales receipt. RTA product's obligation under this warranty is limited to repairing or replacing products or parts as provided herein. This product has been designed for and is intended for office and home-office use only. This warranty is Original Purchaser's sole remedy for product defects, and this warranty does not extend to any product, or damage to any product, caused by or attributed to abuse or misuse, products used for commercial or rental purposes, use modifications of, or attachments to the product, and products or parts not used, maintained, or extended hereunder is in lieu of any and all other warranties, express or implied, including without limitations any implied warranty or merchantability or of fitness for a particular purpose. Please note, all desks made with PVC Laminate surface should not be exposed to direct sunlight, as it may damage the material. Damage of this nature is not covered under this warranty.

RTA Products will not be responsible for indirect, special, incidental or consequential damages. This warranty is limited to merchandise purchased in the Continental United States. Some States do not allow the exclusion or limitation of incidental or consequential damages, so the above limitations or exclusions may not apply to you. This warranty gives you specific legal rights. You may also have other rights that may vary from state to state.

RTA Products will advise you of the procedure to follow in making warranty claims. The following are the procedures for warranty claims:

- a. Call us Monday – Friday, from 9am-5pm (Eastern Time) at (866) 782-8262 to explain the defect and give your name, address and phone number. Please have ready the model number of our product, date and place of purchase. You can also write to us by e-mail to warranty@rtaproducts.com and include the same information.
- b. If we determine that replacement will remedy the situation, and in order to determine the extent or the cause of the defect, purchaser will need to send the part in question at purchaser's expense. Once we receive the part, we will examine it and determine whether the claim is valid (or not), and then proceed to send the replacement. We will ship the replacement at our expense.

TECHNI MOBILI CHAIR WARRANTY

2-YEAR WARRANTY

1. RTA Products, LLC has warranted the Techni Mobili office chairs to the original purchaser who acquired a new product from RTA Products or its authorized resellers of the product against defects in material or workmanship.
2. This warranty is expressly limited to the repair or replacement (at its option) of defective chair components or materials that fails under normal use as a result of a defect in materials or workmanship. This warranty is limited to merchandise purchased in the Continental United States. No assembly labor is included. The word "defects" as used in this warranty, is defined as imperfections that impair the utility of the product.
3. This warranty applies under conditions of normal use, but does not apply to defects that result from intentional damage, negligence, unreasonable use or exposure.
4. Liability for consequential damages is excluded to the extent exclusion is permitted by law. This warranty gives you specific legal rights, and you may have other rights that vary from State to State.
5. RTA Products does not warrant: a) natural variations in character marks b) changes in surface finishes due to aging or exposure to light c) marks, scars, or wrinkles occurring naturally in leather d) failure resulting from normal wear and tear e) the matching of colors, grains, or textures of natural materials f) the colorfastness or the matching of textiles, including an exact match to cuttings or to swatch cards g) damage, marking, or staining of veneer surfaces due to contact with rubber or similar compounds, damage from sharp objects or imprinting from writing instruments, or prolonged exposure to direct sunlight h) we do not warrant products that are exposed to extreme environmental conditions or that have been subject to improper storage.
6. RTA Products shall not be liable for loss of time, inconvenience, commercial loss, or incidental or consequential damages.

7. Any modification to the original product voids the warranty. We do not warrant the performance of the product when used in combination with other than original products.
8. This product has been designed for and is intended for office and home-office use only. This warranty is Original Purchaser's sole remedy for product defects, and this warranty does not extend to any product, or damage to any product, caused by or attributed to abuse or misuse, products used for commercial or rental purposes, use modifications of, or attachments to the product, and products or parts not used, maintained, or extended hereunder is in lieu of any and all other warranties, express or implied, including without limitations any implied warranty or merchantability or of fitness for a particular purpose.
9. Report any defects to RTA Products, LLC together with your sales receipt or other proof of purchase. If the chair is defective within the terms of the warranty, RTA Products, LLC will furnish a replacement chair (at its option) at no cost of equal or similar value and design.
10. RTA Products will advise you of the procedure to follow in making warranty claims. The following are the procedures for warranty claims:
 - a) Call us Monday – Friday, from 9am-5pm (Eastern Time) at (866) 782-8262 to explain the defect and give your name, address and phone number. Please have ready the model number of our product, date and place of purchase. You can also write to us by e-mail to warranty@rtaproducts.com and include the same information.
 - b) If we determine that replacement will remedy the situation, and in order to determine the extent or the cause of the defect, purchaser will need to send the part in question at purchaser's expense. Once we receive the part, we will examine it and determine whether the claim is valid (or not), and then proceed to send the replacement. We will ship the replacement at our expense.

2COOL PRODUCT WARRANTY

ONE (1) YEAR LIMITED WARRANTY

2COOL warrants this product against defects in materials and/or workmanship under normal use for a period of ONE (1) YEAR from the date of purchase by the original purchaser ("Warranty Period"). If a defect arises and a valid claim is received within the Warranty Period, at its option, 2COOL will either 1) repair the defect at no charge, using new or refurbished replacement parts, or 2) replace the product with a new product that is at least functionally equivalent to the original product.

Obtaining Service: To obtain warranty service, call 2COOL Limited Warranty Service at 1-866-782-8262. Please be prepared to describe the product that needs service and the nature of the problem. A purchase receipt is required. All repaired and replacements must be authorized in advance. Service options, parts availability and response times will vary. You are responsible for delivery and the cost of delivery of the product or any parts to the authorized service center for replacement, per our instructions.

Limits and Exclusions: Coverage under this Limited Warranty is limited to the Continental United States of America. This warranty does not apply to: a) damage caused by failure to follow instructions relating to the product's use or the installation of components; b) damage caused by accident, abuse, misuse, fire, floods, earthquake or other external causes; c) damage caused by service performed by anyone who is not a representative of 2COOL; d) accessories used in conjunction with a covered product; e) a product or part that has been modified to alter functionality or capability; f) items intended to be periodically replaced by the purchaser during the normal life of the product including, without limitation, batteries or light bulbs; g) any product sold "as is" including, without limitation, floor demonstration models and refurbished items; or h) a product that is used commercially or for a commercial purpose.

2COOL shall not be liable for incidental or consequential damages resulting from the use of this product, or arising out of any breach of this warranty. To the extent permitted by applicable law, 2COOL disclaims any and all statutory or implied warranties, including, without limitation, warranties of merchantability, fitness for a particular purpose and warranties against hidden or latent defects. If 2COOL cannot lawfully disclaim statutory or implied warranties, then to the extent permitted by law, all such warranties shall be limited in duration to the duration of this express warranty.

Some states disallow the exclusion or limitation of incidental or consequential damages or how long an implied warranty lasts, so the above exclusions or limitations may not apply to you. This warranty gives you specific legal rights and you may also have other rights, which vary from state to state.