

English

# ASSEMBLY INSTRUCTIONS

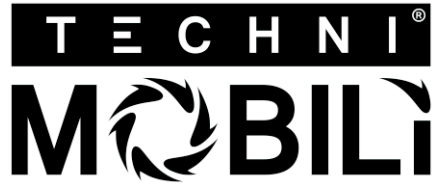

MODEL RTA - 2706A

Thanks for purchasing one of our products.  
Please read carefully the assembly instructions before the installation.  
Please save this manual for future reference.

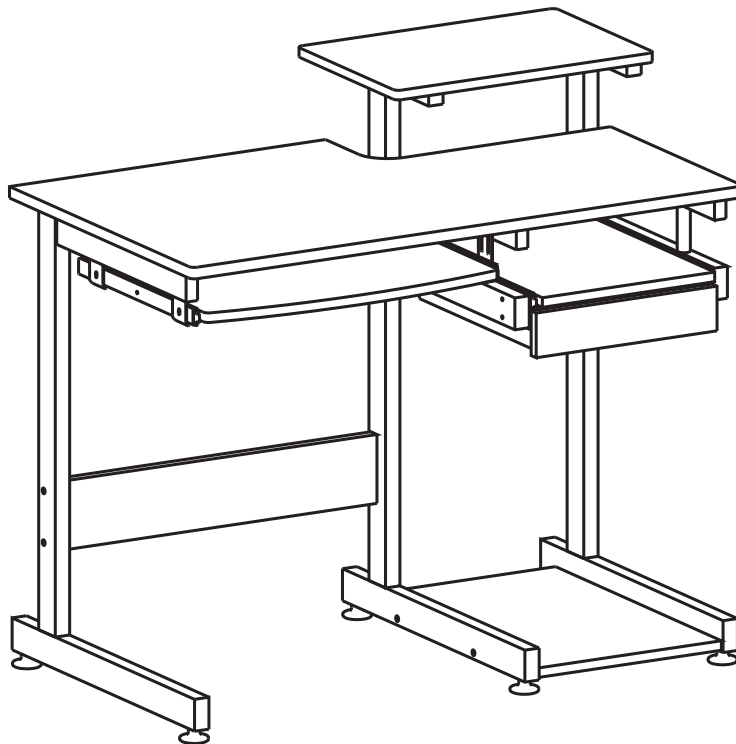

MODEL RTA-2706A



Spanish

# INSTRUCCIONES DE ENSAMBLAJE.

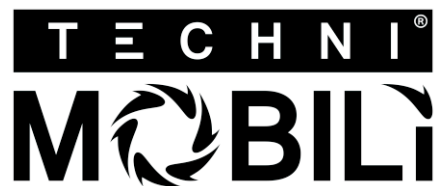

MODELO RTA - 2706A

Gracias por comprar uno de nuestros productos.  
Por favor lea cuidadosamente las instrucciones de ensamblaje antes de instalar la unidad.  
Por favor guarde este manual para referencias futuras.

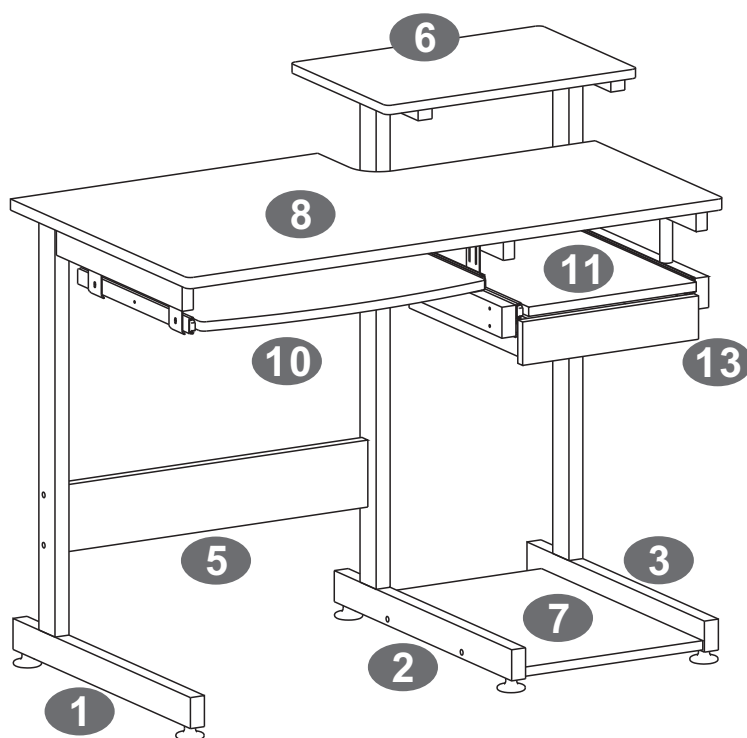

MODELO RTA-2706A

# RTA-2706A

## DIMENSIONS

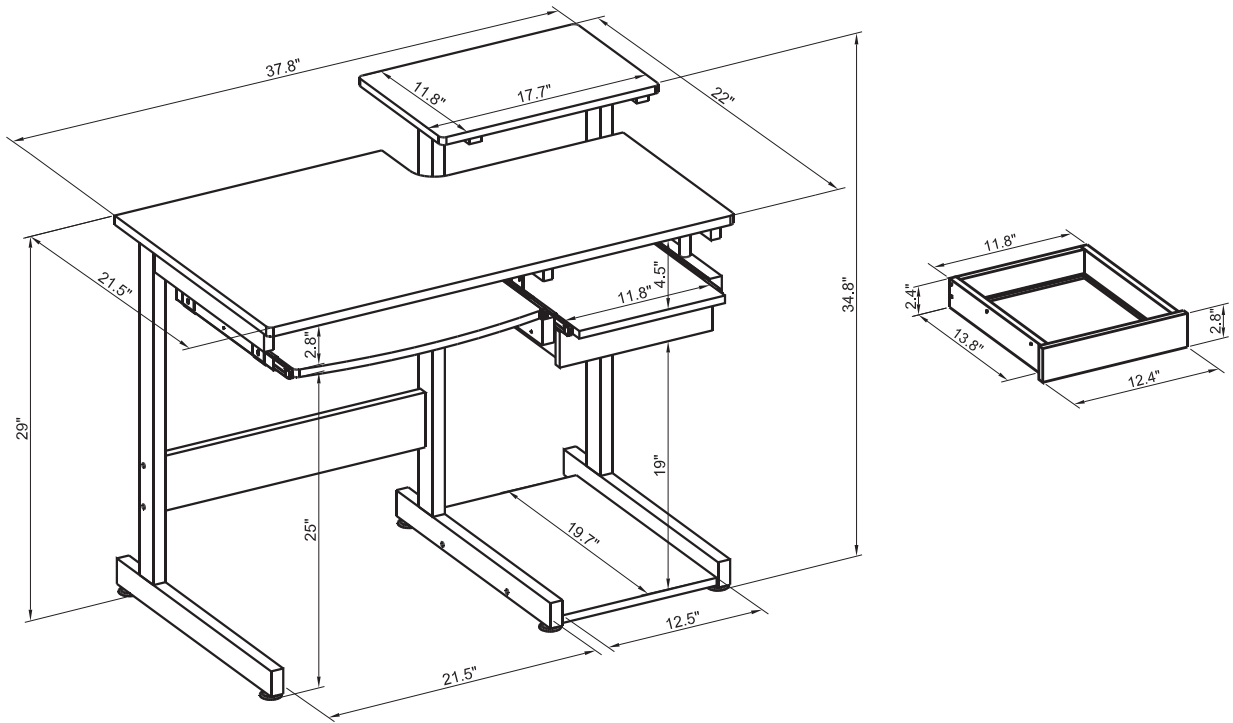

Product Size: 37.8"W x 22"D x 34.8"H

## MAXIMUM WEIGHT CAPACITIES

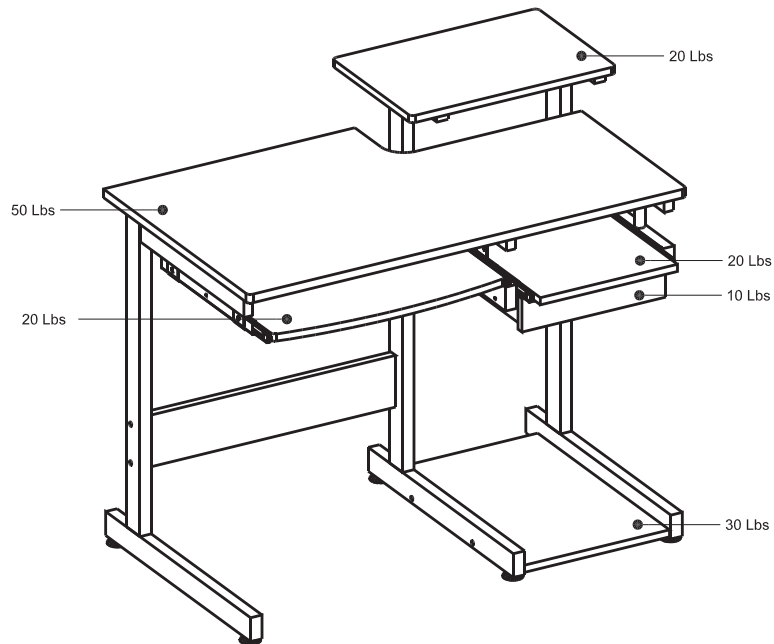

**DO NOT** exceed this limit  
Please use care and good judgement  
when placing objects on wood surface

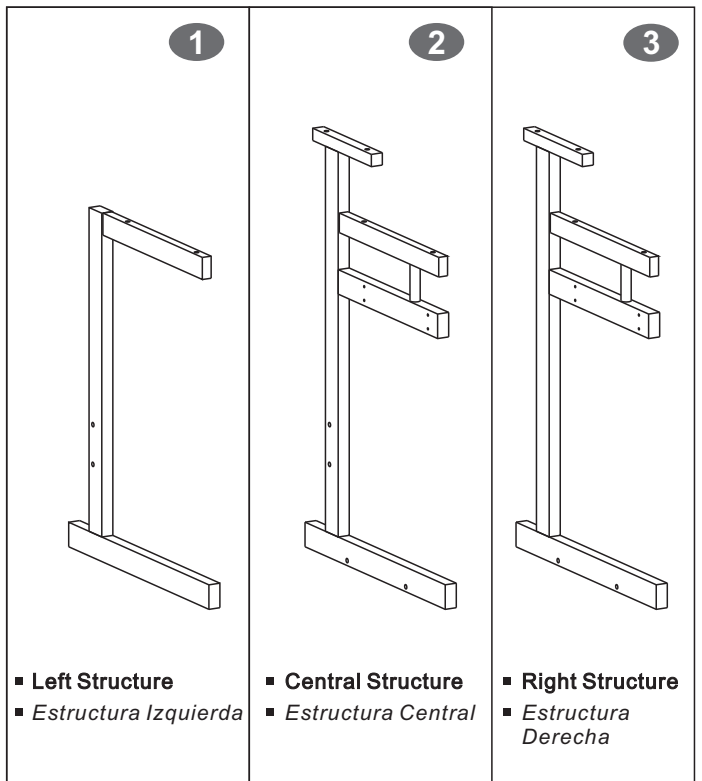
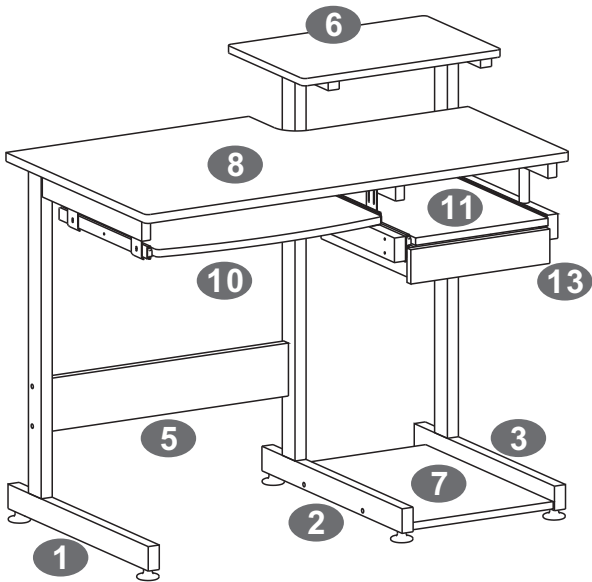

▪ PARTS LIST    ▪ LISTA DE PARTES





<p>4</p> <p>X6</p> <ul style="list-style-type: none"> <li>▪ Studs</li> <li>▪ Topes</li> </ul>	<p>5</p> <ul style="list-style-type: none"> <li>▪ Back Panel</li> <li>▪ Panel Posterior</li> </ul>	<p>6</p> <ul style="list-style-type: none"> <li>▪ Monitor Panel</li> <li>▪ Panel de Monitor</li> </ul>	<p>7</p> <ul style="list-style-type: none"> <li>▪ CPU Panel</li> <li>▪ Panel Para Cpu</li> </ul>
<p>8</p> <ul style="list-style-type: none"> <li>▪ Main Panel</li> <li>▪ Panel Principal</li> </ul>		<p>9</p> <p>X4</p> <ul style="list-style-type: none"> <li>▪ Hooks</li> <li>▪ Bases</li> </ul>	
<p>11</p> <ul style="list-style-type: none"> <li>▪ Auxiliary Panel</li> <li>▪ Panel Auxiliar</li> </ul>		<p>13</p> <ul style="list-style-type: none"> <li>▪ Drawer</li> <li>▪ Gaveta</li> </ul>	<p>14</p> <p>2SETS</p> <p>Derecho Right</p> <p>Left Izquierdo</p> <ul style="list-style-type: none"> <li>▪ Sliders</li> <li>▪ Deslizadores</li> </ul>
<p>12</p> <p>1 SET</p> <ul style="list-style-type: none"> <li>▪ Slider For Drawer</li> <li>▪ Deslizadores para gaveta</li> </ul>			

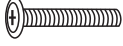
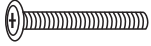

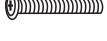
▪ SCREWS    ▪ TORNILLOS

PART	QTY.	ITEM	
<b>A</b>	4	6X35 MM	
<b>B</b>	14	6X50 MM	
<b>C</b>	8	4X14 MM	
<b>D</b>	4	4X4 MM	
<b>E</b>	8	4X28 MM	

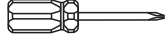
PART	QTY.	ITEM	
<b>F</b>	4	3X15 MM	
<b>G</b>	4	6X12 MM	
	1		



**GENERAL ASSEMBLY TIPS AND TROUBLESHOOTING DURING ASSEMBLY:**

- \*Before you start assembling, make sure you have all the parts and necessary hardware by doing a quick inventory.
- \*Follow the assembly instructions step by step, and do not skip any unless advised to do so by RTA PRODUCTS' Customer Service.
- \*On each step, and to avoid misalignments, always leave screws loose, and do not tighten them until all are in place.
- \*In wood panels, the laminate might be covering the holes.  
If there are no visible holes: Pass the tip of your finger around the area where the hole should be, and press against the surface to feel the indentation.  
If the hole looks too small for the screw or bolt: carefully perforate the laminate with the tip of a pen.

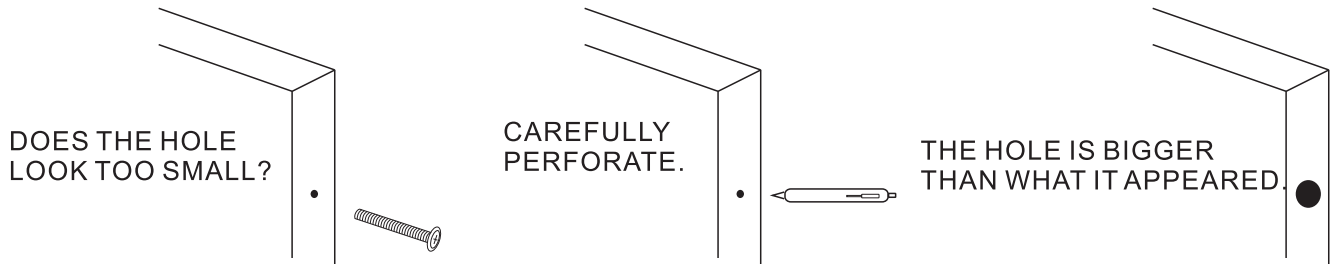

- \*In wood panels, some might have inserts that look like screws. Those inserts are either nuts or cam locks. Make sure they are aligned to receive the screws or bolts.

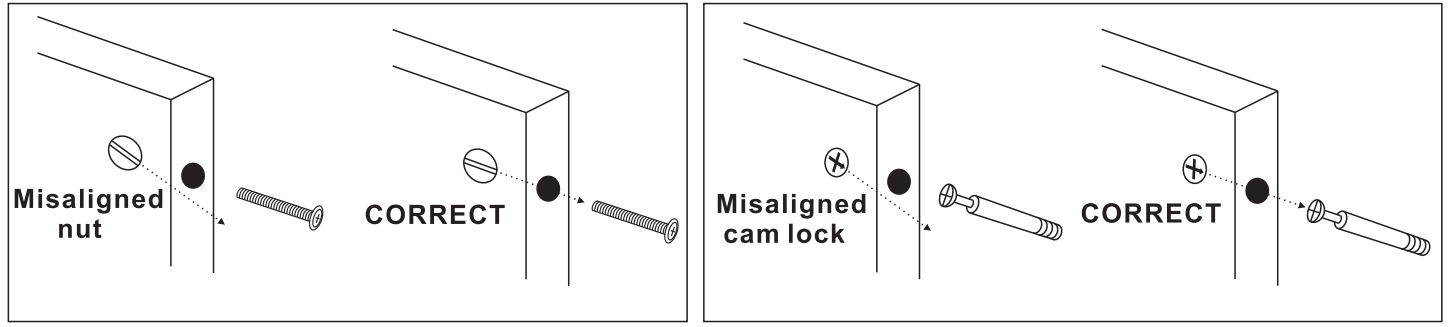

- \*Make sure to use the correct screws or bolts, and do not overtighten them. Using wrong screws or overtightening them might cause damage to the parts, and such damage is not covered by the product's warranty.

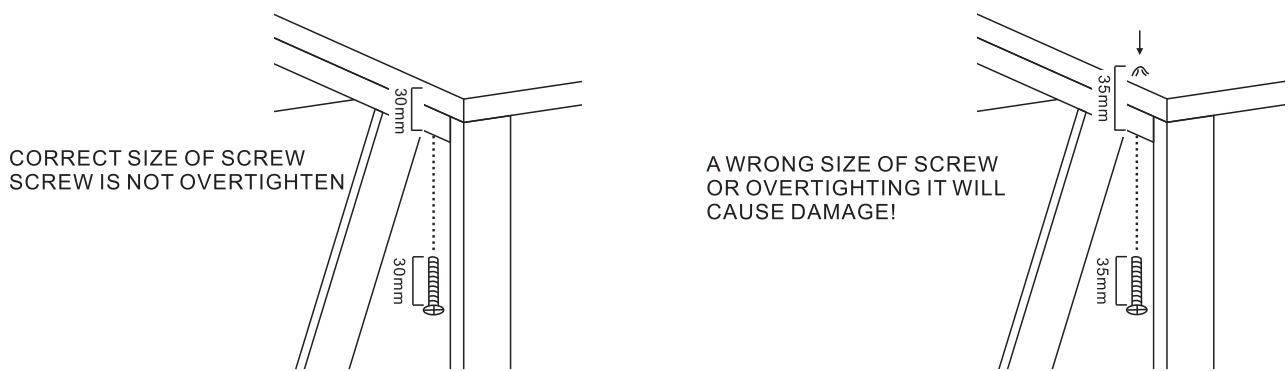

**CONSEJOS PARA RESOLVER PROBLEMAS DURANTE EL ENSAMBLAJE:**

- \*Antes de comenzar, haga un inventario rápido para asegurarse de tener todas las partes y tornillos necesarios.
- \*Siga las instrucciones paso por paso, y no se salte ninguno a menos que se lo aconseje un representante de Servicio al Cliente de RTA PRODUCTS.
- \*Para evitar desalineamientos, en cada paso que haga deje los tornillos medio puestos, y no los apriete hasta que todos estén colocados en sus lugares.
- \*En paneles de madera, el laminado podría cubrir las perforaciones.  
**Si no ve los hoyos:** Pase la punta del dedo por el area y presione contra la superficie para encontrar el hoyo.  
**Si el hoyo luce muy pequeño para el tornillo o perno:** Con cuidado perforo el laminado con la punta de un lapicero (bolígrafo, pluma).

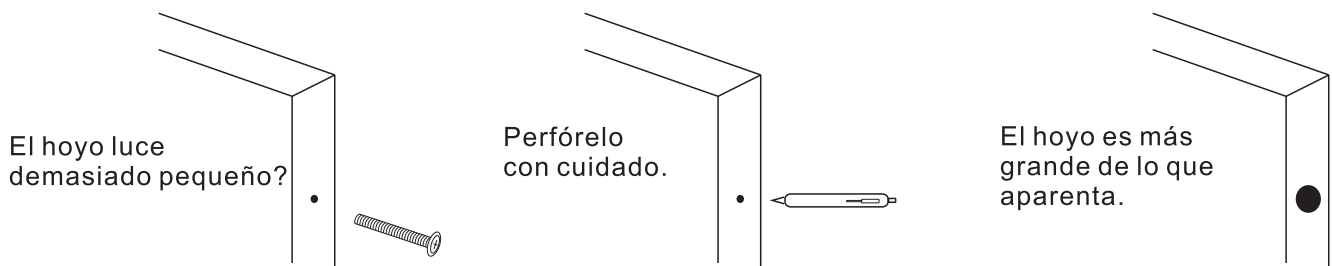

- \*Algunos paneles pueden tener insertados lo que parecen tornillos, pero son tuercas o cerrajes: Asegúrese que estén alineados para recibir el tornillo o perno.

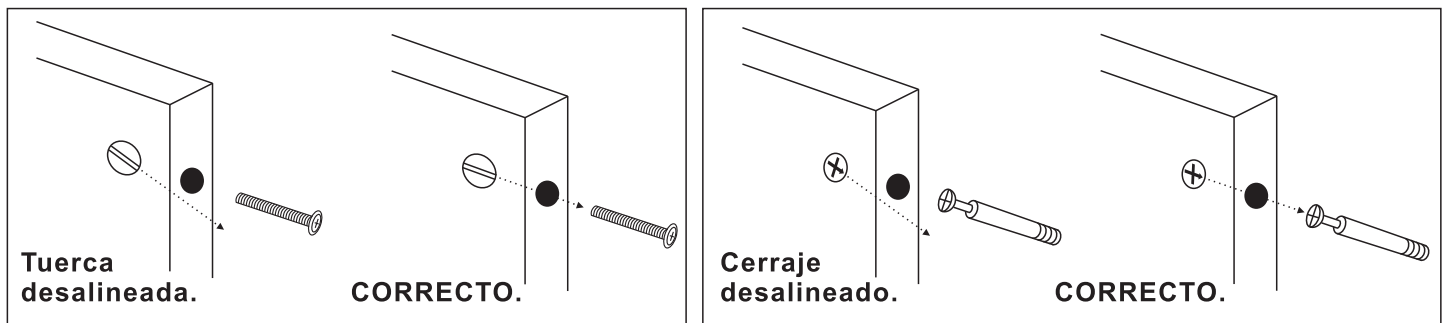

- \*Asegúrese de usar los tornillos y pernos correctos, y no los apriete demasiado. Usar tornillos/pernos de tamaño incorrecto o sobre-apretarlos puede causar daño a las partes, lo cual no es cubierto por la garantía del producto.

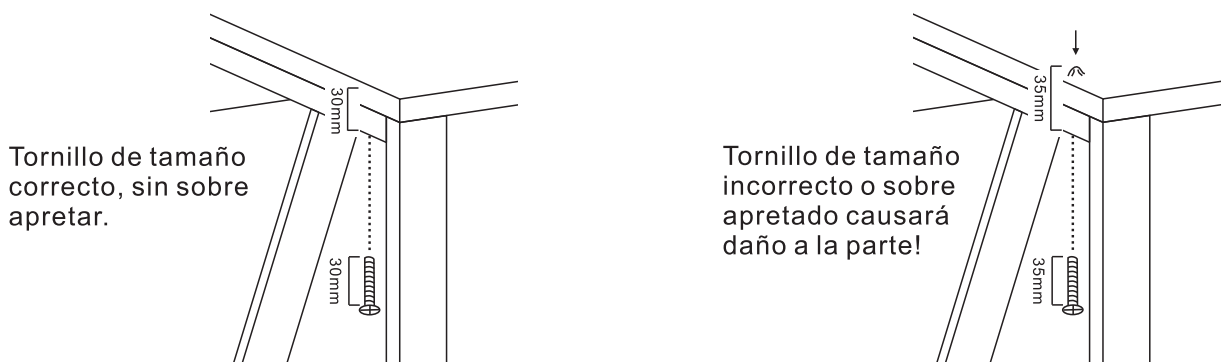

## ▪ STEPS

## ▪ PASOS

1

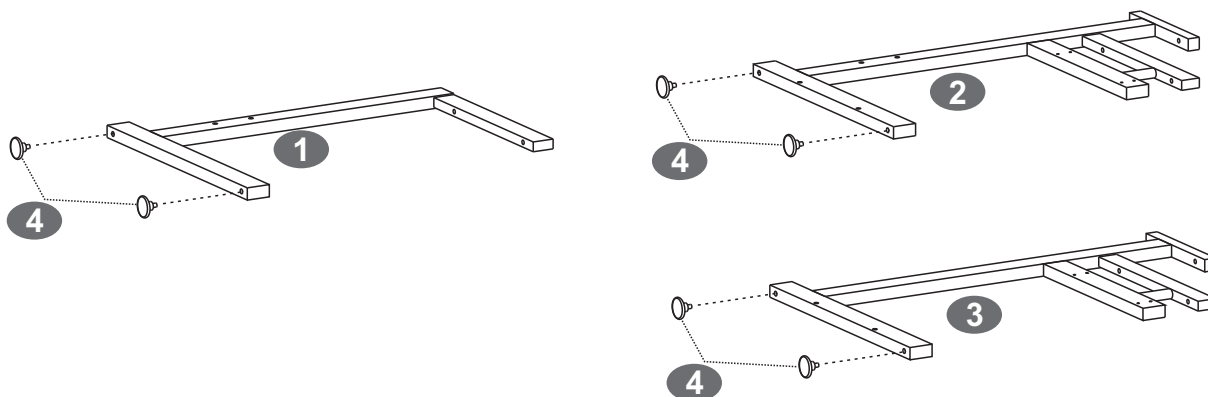

- Insert the Studs (4) at the bottom of the Left, Central & Right Structures (1,2&3).
- Inserte los topes (4) en las patas de las estructuras izquierda, derecha y central (1,2,3).

2

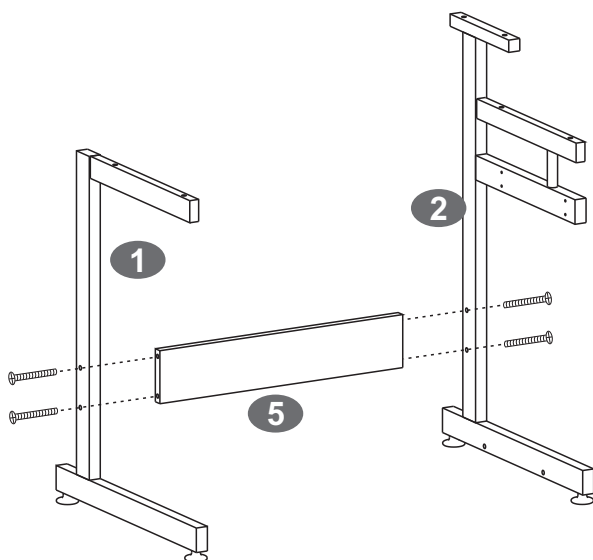

Before doing this step, make sure that all the nuts in the panel are properly aligned to receive the screws!

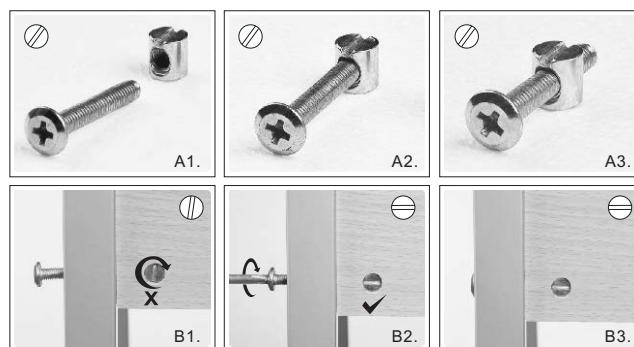

Antes de hacer este paso, asegúrese que las tuercas en el panel estén alineadas para recibir los tornillos!

## ▪ SCREWS ▪ TORNILLOS

**B** 6X50 MM

4PCS



- Use screws B to assemble the Back Panel (5) between the Left & Central Structures (1 & 2).
- Use tornillos B para ensamblar el panel posterior (5) entre las estructuras central e izquierda (1, 2).



3

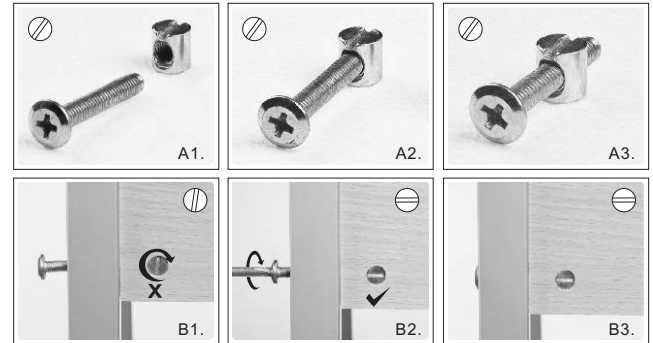
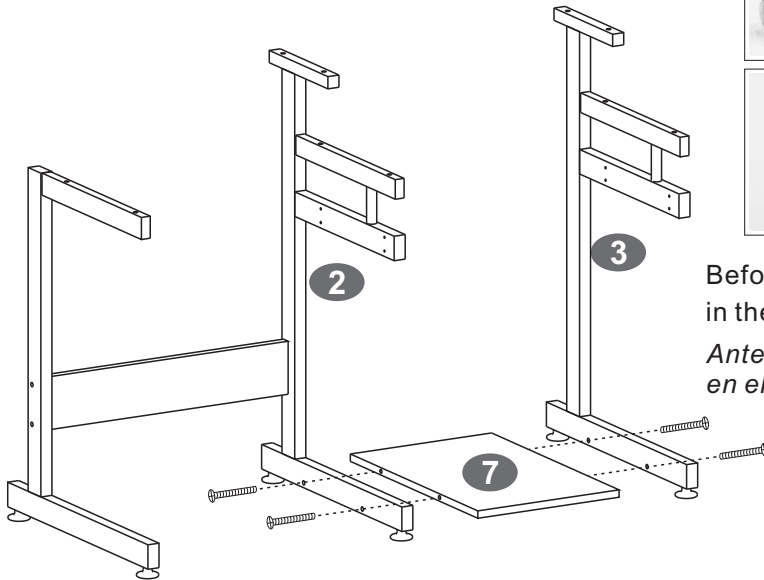

Before doing this step, make sure that all the nuts in the panel are properly aligned to receive the screws!

*Antes de hacer este paso, asegúrese que las tuercas en el panel estén alineadas para recibir los tornillos!*

▪ SCREWS ▪ TORNILLOS

**B** 6X50 MM

4PCS



- Use screws B to assemble the CPU Panel (7) between the Central and Right Structure (2&3).
- Use tornillos B para ensamblar el Panel de Cpu (7) entre las estructuras Central y Derecha y así quedaran conectadas las (3) estructuras.

4

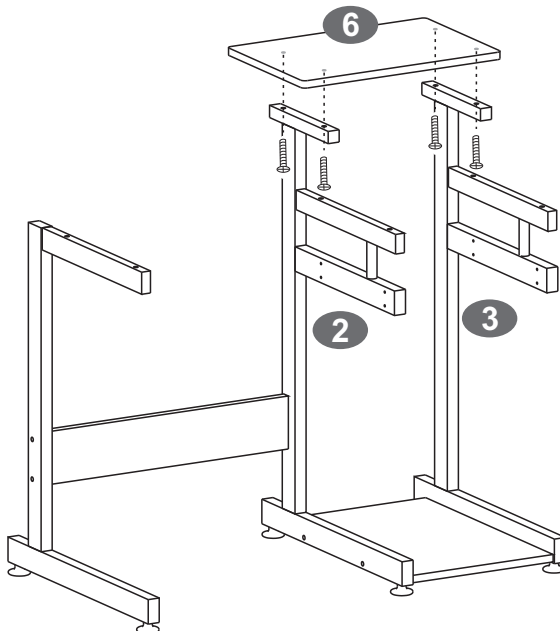

▪ SCREWS ▪ TORNILLOS

**A** 6X35 MM

4PCS



- Use screws A to fix the Monitor Panel (6) to Central & Right Structure (2&3).
- Use tornillos A para ensamblar el Panel para Monitor (6) a las estructuras derecha y central (2,3).

5

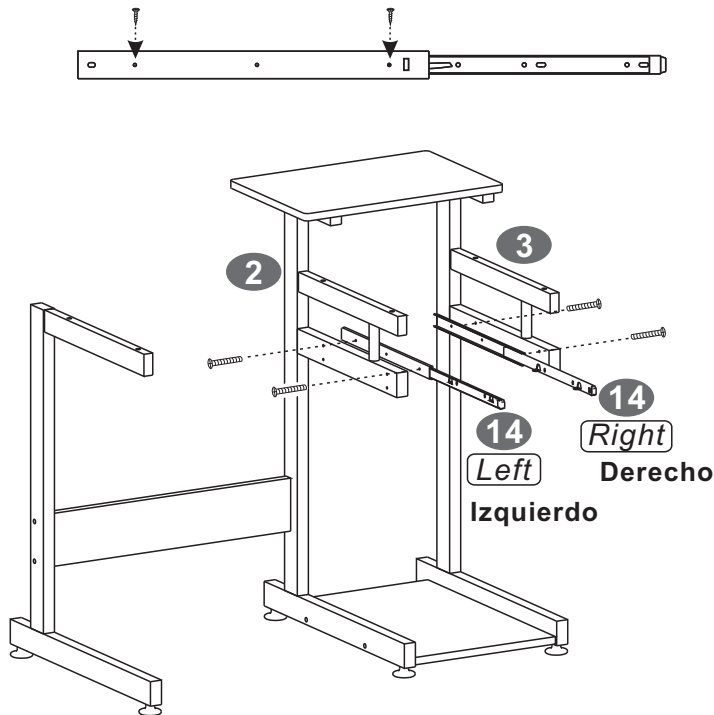

▪ SCREWS ▪ TORNILLOS

**E** 4X28 MM

4PCS



- Use screws E to assemble one pair of Sliders (14) to the Central & Right Structures (2&3) noting that they must slide-out to the front of the desk. You will find four holes in the metal structures, use the top two.
- Use Tornillos E para fijar el lado grueso de dos de los deslizadores (14) a las Estructuras derecha y central (2,3) tomando en cuenta que deben poder deslizarse hacia el frente del mueble. En la estructura encontrara 4 huecos de cada lado, use los de arriba.

6

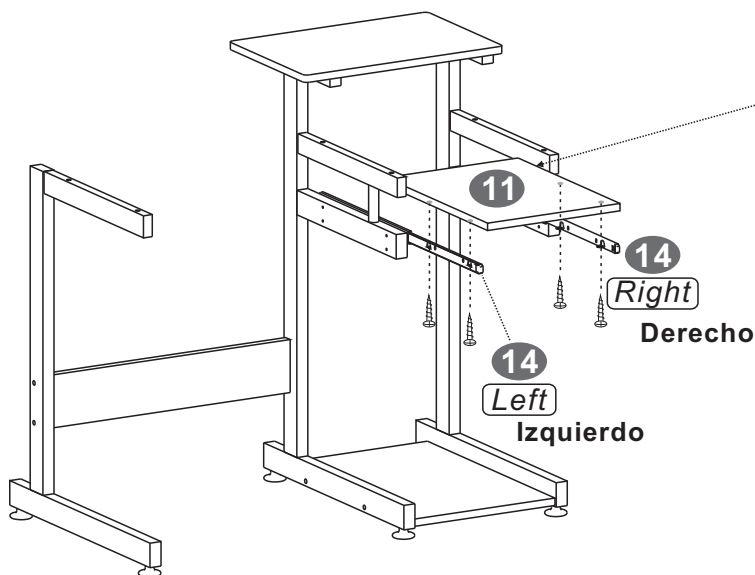

▪ SCREWS ▪ TORNILLOS

**C** 4X14 MM

4PCS



- Use screws C to fix the back face of the Auxiliary Panel (11) to the Sliders (14).
- Con tornillos C y por la cara posterior del panel Auxiliar (11) fijelo a los deslizadores (14).

7

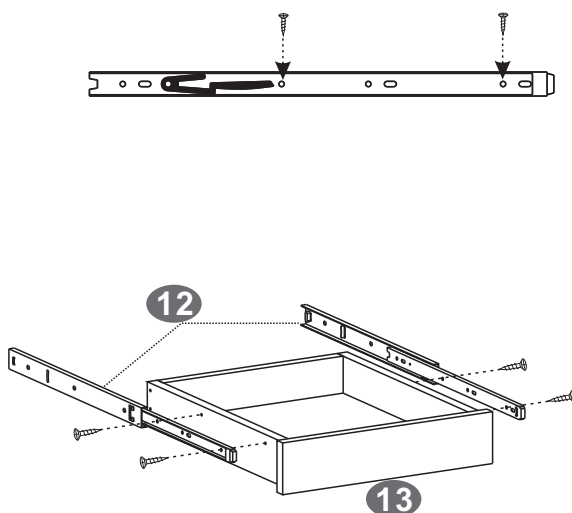

▪ SCREWS ▪ TORNILLOS

**F** 3X15 MM

4PCS



- Use screws F to assemble the thinner part of the Sliders (12) to the Drawer (13).
- Use tornillos F para fijar los deslizadores de gaveta (12) a la Gaveta (13), note que debe fijar la parte delgada del deslizador.

8

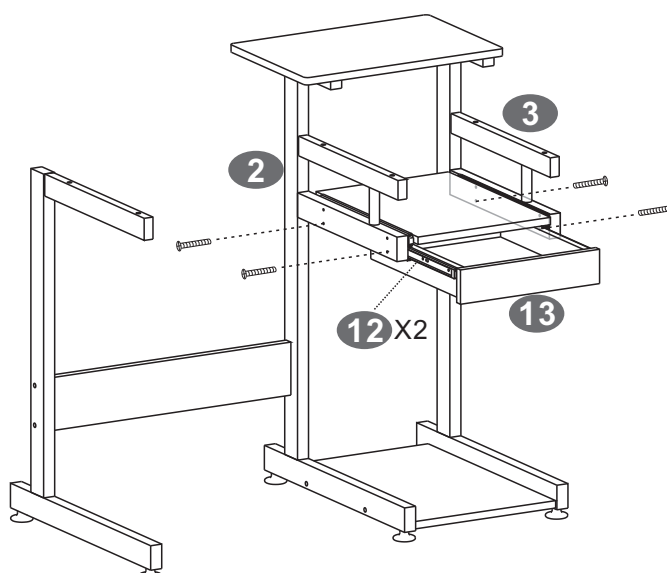

▪ SCREWS ▪ TORNILLOS

**E** 4X28 MM

4PCS



- Use screws E to assemble the wider part of the Drawer's sliders (12) to the Central & Right Structures (2&3).
- Con tornillos E fije la parte gruesa de los deslizadores de Gaveta (12) a las estructuras derecha y central (2,3).

9

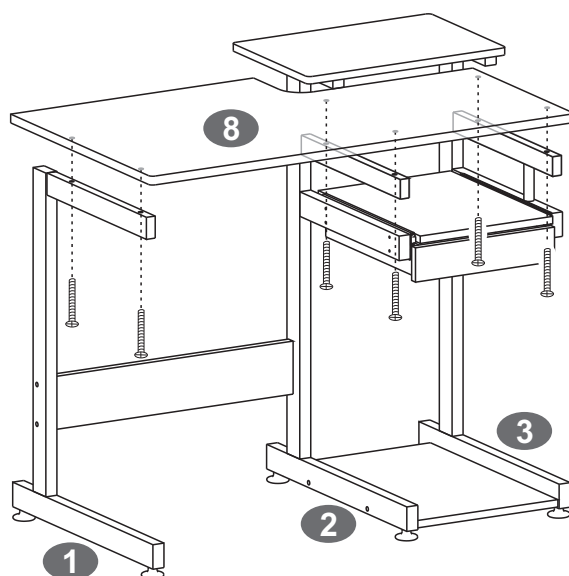

▪ SCREWS ▪ TORNILLOS

**B** 6X50 MM

 6PCS



- Use screws **B** to assemble the back face of the Main Panel (8) to the Main Structures (1,2&3).
- Use tornillos **B** para fijar el Panel Principal (8) a las estructuras derecha, izquierda y central (1,2,3).

10

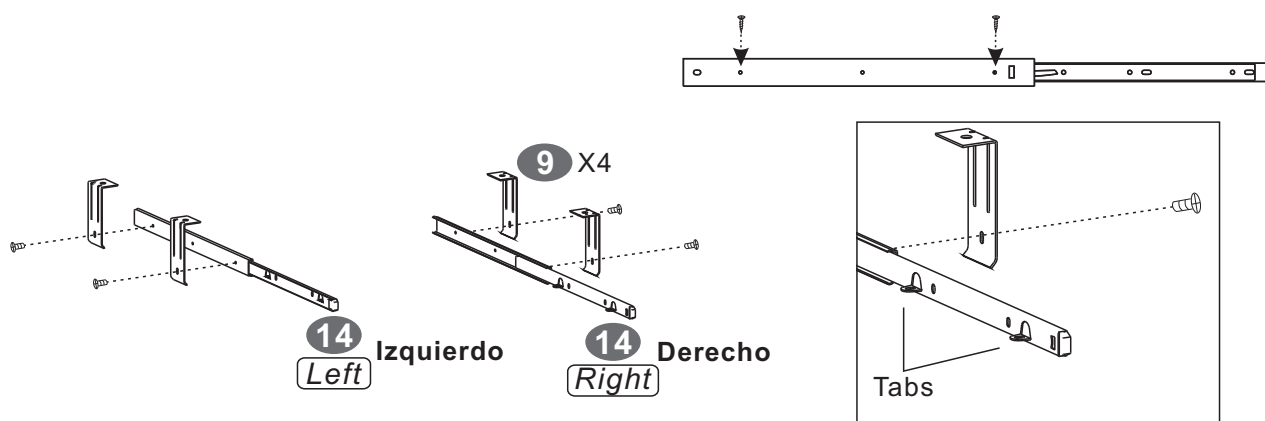

▪ SCREWS ▪ TORNILLOS

**D** 4X4 MM

 4PCS



- Use screws **D** to fix the Hooks (9) to the other pair of Sliders (14).
- Use Tornillos **D** para fijar la parte gruesa de los otros dos deslizadores (14) a las bases (9).

11

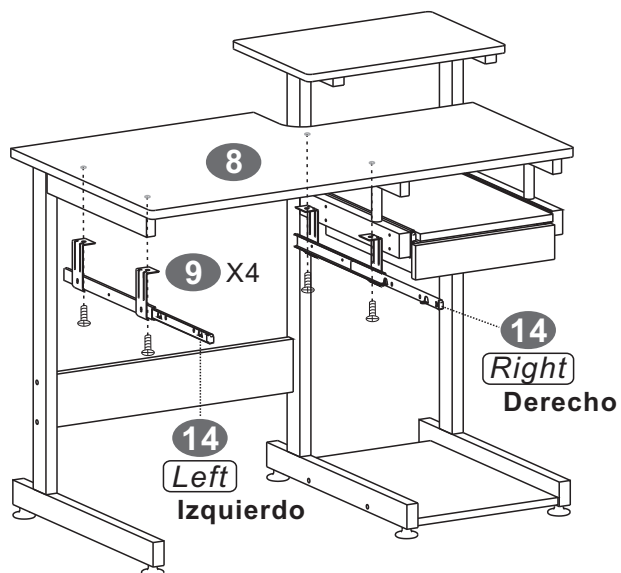

- Use screws G to fix the Hooks (9) to the underside of the Main Panel.
- Use tornillos G para fijar las bases (9) a la parte inferior del Panel Principal (8).

▪ SCREWS ▪ TORNILLOS

**G** 6X12 MM

4PCS



12

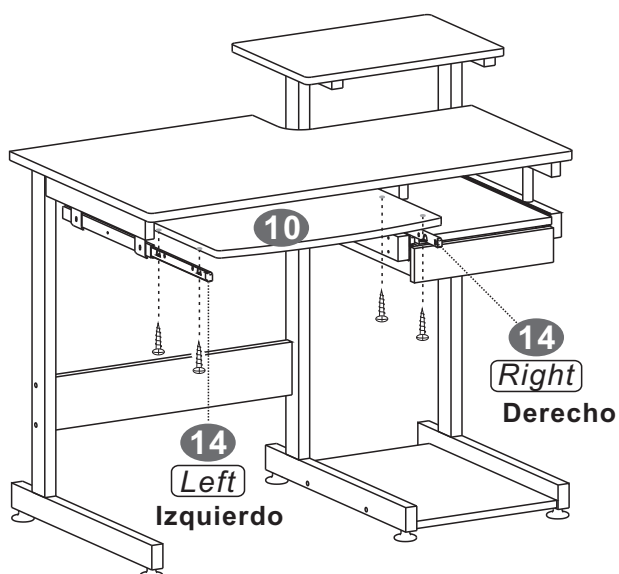

- Use screws C to assemble the back face of the Keyboard Panel (10) to the Sliders (14).
- Con tornillos C y por debajo, ensamble el Panel de Teclado (10) con los deslizadores (14).

▪ SCREWS ▪ TORNILLOS

**C** 4X14 MM

4PCS



# CARE AND MAINTENANCE

## English

- DO NOT EXPOSE THE SURFACES TO DIRECT SUNLIGHT, OR EXTREME ENVIRONMENTAL CONDITIONS. EXPOSURE WILL DAMAGE THE PRODUCT, WHICH IS NOT COVERED BY THE WARRANTY.
- DO NOT USE SOLVENTS OVER SURFACES OR STRUCTURAL TUBES. SURFACES MUST BE CLEANED WITH A SOLUTION OF A SMOOTH SOAP AND WATER, THEN CLEARED WITH A DRY TOWEL.
- PRODUCTS THAT ARE HEAVY SHOULD BE LIFTED OR MOVED BY AT LEAST 2 PERSONS, AND ALL OBJECTS SHOULD BE REMOVED FROM THE PRODUCT.

## Spanish

- NO EXPONGA LAS SUPERFICIES A LA LUZ SOLAR DIRECTA, O A CONDICIONES AMBIENTALES EXTREMAS. ESTE TIPO DE DAÑOS NO SON CUBIERTOS POR LA GARANTÍA DEL PRODUCTO.
- NO USE SOLVENTES SOBRE LAS SUPERFICIES O TUBOS ESTRUCTURALES. LAS SUPERFICIES DEBEN SER LIMPIADOS CON UN JABÓN SUAVE Y AGUA, Y SECADOS INMEDIATAMENTE CON UNA TOALLA LIMPIA Y SECA.
- PRODUCTOS QUE SON PESADOS DEBEN LEVANTARSE O MOVERSE POR AL MENOS 2 PERSONAS, Y TODOS LOS OBJETOS DEBEN SER REMOVIDOS DEL PRODUCTO.

## PRODUCT WARRANTY

### TECHNI MOBILI DESK WARRANTY LIMITED 5-YEAR WARRANTY



RTA Products, LLC warrants to the Original Purchaser who acquired a new product from RTA Products or its authorized resellers that this product will be free from defects in its workmanship and materials, under normal use and service conditions, as described herein. "Defects" as used in this warranty, is defined as any imperfections that impair the use of the furniture or product. RTA products will repair or replace, at its option, without charge to the original purchaser 'other than freight from purchaser to RTA Products, only the defective products or parts for a period of FIVE (5) Years.

Replacement parts can only be supplied if parts are available. Items out of production may be unavailable. This warranty will be effective for the applicable time period beginning the date of purchase on your original sales receipt. RTA product's obligation under this warranty is limited to repairing or replacing products or parts as provided herein. This product has been designed for and is intended for office and home-office use only. This warranty is Original Purchaser's sole remedy for product defects, and this warranty does not extend to any product, or damage to any product, caused by or attributed to abuse or misuse, products used for commercial or rental purposes, use modifications of, or attachments to the product, and products or parts not used, maintained, or extended hereunder is in lieu of any and all other warranties, express or implied, including without limitations any implied warranty or merchantability or of fitness for a particular purpose. Please note, all desks made with PVC Laminate surface should not be exposed to direct sunlight, as it may damage the material. Damage of this nature is not covered under this warranty.

RTA Products will not be responsible for indirect, special, incidental or consequential damages. This warranty is limited to merchandise purchased in the Continental United States. Some States do not allow the exclusion or limitation of incidental or consequential damages, so the above limitations or exclusions may not apply to you. This warranty gives you specific legal rights. You may also have other rights that may vary from state to state.

RTA Products will advise you of the procedure to follow in making warranty claims. The following are the procedures for warranty claims:

- a. Call us Monday – Friday, from 9am-5pm (Eastern Time) at (866) 782-8262 to explain the defect and give your name, address and phone number. Please have ready the model number of our product, date and place of purchase. You can also write to us by e-mail to [warranty@rtaproducts.com](mailto:warranty@rtaproducts.com) and include the same information.
- b. If we determine that replacement will remedy the situation, and in order to determine the extent or the cause of the defect, purchaser will need to send the part in question at purchaser's expense. Once we receive the part, we will examine it and determine whether the claim is valid (or not), and then proceed to send the replacement. We will ship the replacement at our expense.