

WONDER WALL

ASSEMBLY NOTES

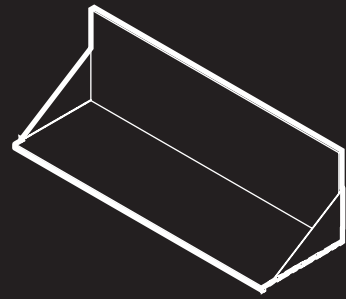

TAKE A SAD WALL
MAKE IT BETTER

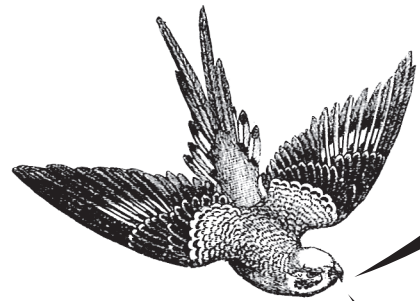

CARE

Clean back panel with a slightly damp, soft cloth. To remove dirt and fingerprints, use a quality cleaner formulated for wood furniture. Wipe completely dry with a soft cloth in the direction of the wood grain.

Clean powder-coated shelf with a soft cloth or sponge using a mild detergent, such as dish soap, and warm water. Wipe completely dry with a soft cloth.

PARTS

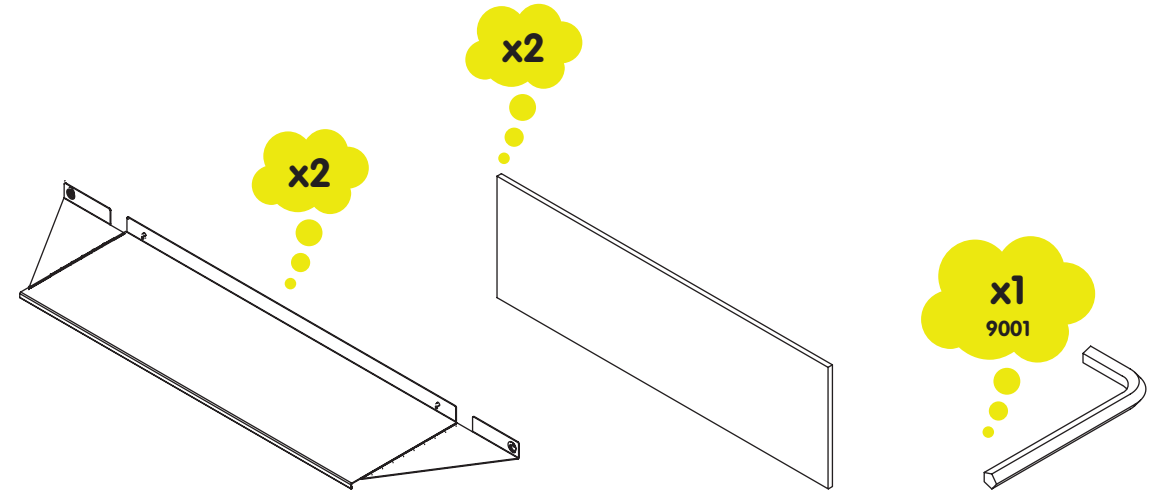

1

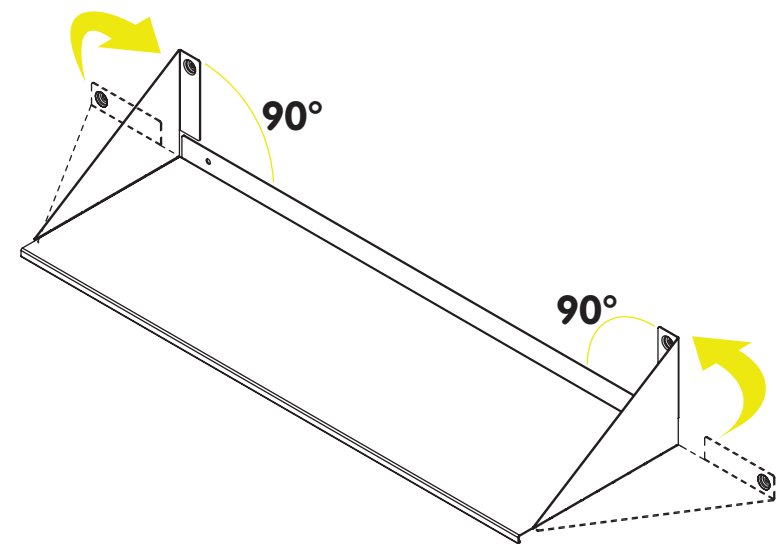

2

Installation of the Wonder Wall is not for the faint of heart. We recommend professional installation to ensure proper mounting.

*

To determine the hardware best suited for your type of wall and anticipated load, consult your local hardware professional.

36 3/8"

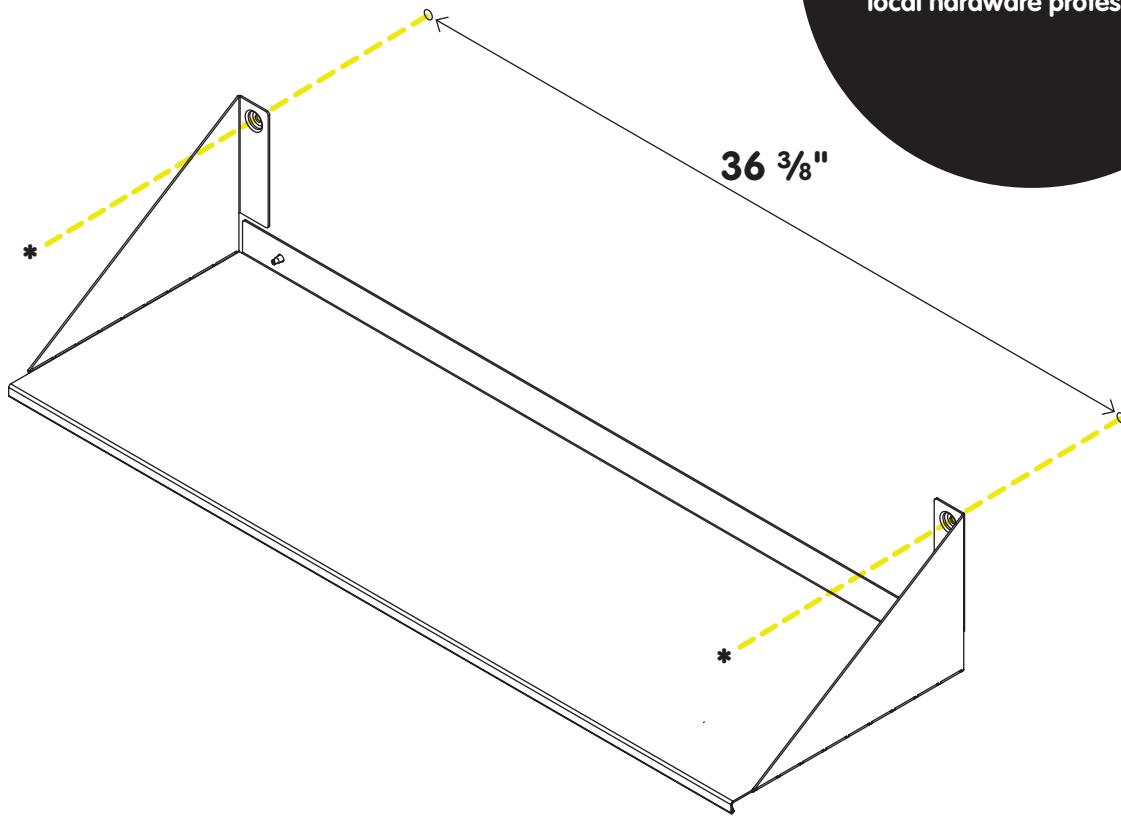

NOTE

To lift the front: use the hex key to turn both levelers clockwise

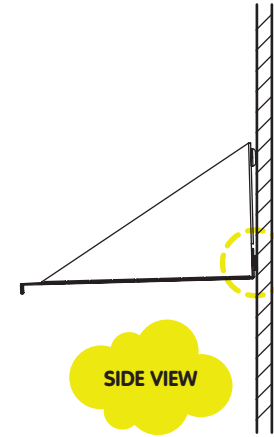

SIDE VIEW



FRONT VIEW

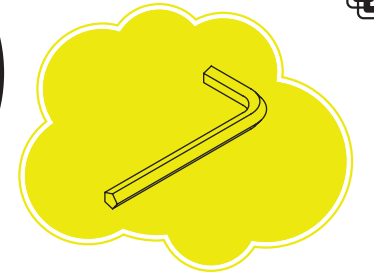

NOTE

To lower the front: use the hex key to turn both levelers counterclockwise

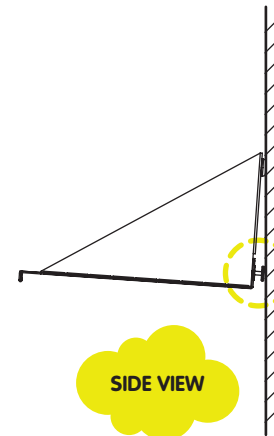

SIDE VIEW



FRONT VIEW

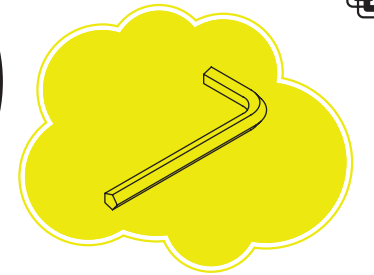

4

IT'S MAGNETIC!



PANEL BACK VIEW

