



Double Bookshelf Pot Rack Installation Instructions

Thank you for purchasing the Rogar International Shelf and Pot Rack. Installation of this storage unit is quick and easy, requiring only routine hand tools.

1. Tools required:

- Drill
- Hex Wrench (supplied with rack)
- Level
- Pencil
- Pliers or Wrench (small crescent wrench works well)
- Screwdriver (Phillips)
- Tape Measure

A method of locating the wall studs is required. An electronic, sonic, or magnetic stud finder is best, though other means may be utilized.

2. Parts List -check the contents of the box to insure all parts have been included.

- A. Shelf (2 each)
- B. Vertical Support Arms (2 each)
- C. Grid (2 each)
- D. Button Head Screws (4 each)
- E. Acorn Nut (4 each)
- F. 1-1/4" Wood Screws (8 each)
- G. Plastic Wall Anchors (8 each, Optional Use)
- H. Hex Wrench (1 each)
- I. Eye Hooks (6 each) & "S" Hooks (2 each)

Parts A, B & C depicted in Figure 1; D & E are depicted in Figure 2; and F in Figure 3.

3. Planning the Installation of Bookshelf Pot Rack

Caution: The Pot Rack should be attached directly to structural framing members, such as wall studs. Mounting to wallboard, plaster, etc., is not recommended even if using the optional wall , toggle bolts, as they may not be adequate.

The Pot Rack, when loaded with books, cookware, utensils, etc., is quite heavy. Therefore, the supplied screws should be attached directly to the wall studs, or other structural framing members. When deciding where to hang the Pot Rack, access to the wall studs should be considered. Do not put grids in shelves until after attaching the rack to the wall.

4. Hanging The Pot Rack:

The Pot Rack design allows for mounting on common 16-inch center studs. The three mounting holes on each shelf are 16 inches apart, and the vertical support arms should be attached with the mounting holes 32 inches apart.

Refer to figure 3. Locate the wall studs on the wall at the height you want to mount the shelf. With a pencil, mark the location of 3 side-by-side studs. The marks should be approximately 16 inches apart.

In the following sequence, drill eight holes using a drill bit slightly smaller than the threaded section of the wood screws. Make sure the bit drills into the wall stud; if it drills into an open area, search for the wall stud, and drill a new hole.

Drill a hole for the center wood screw on the top shelf and attach the shelf to the wall. Do not set the wood screw firmly at this time, because the shelf must move to level it.

With the use of a level, or by measuring the distance from the floor at both ends, adjust the top shelf to a level position and mark the remaining two screw holes. Rotate the shelf up or down in order to drill the two marked mounting holes. Screw in two wood screws; again do not set the screws firmly.

For the bottom shelf; drill holes for the center and two outer screws, 11 1/2" inches below the centers of the screws in the top shelf. Attach the bottom shelf to the wall but do not set the screws firmly at this time. **Note:** The bottom edge of the top shelf should be 10" inches above the top edge of the bottom shelf and level with it.

Refer to figure 2. Attach the two vertical support arms to the shelves with the button head screws and acorn nuts. Only finger tighten the screws at this time. **Note:** Acorn nuts and button head screws can be reversed if desired.

Align the two vertical support arms with the two outermost wall studs and mark the screw holes with pencil. (Loosen the screws if necessary in order to slightly twist the arms exposing the hole marks.) Confirm the marks are over studs and 32 inches apart (both parts should visually look perpendicular to the shelf.) Drill two holes and screw in the wood screws.

Tighten all screws, lay in the grids and hang the hooks to complete the installation of your new rack.

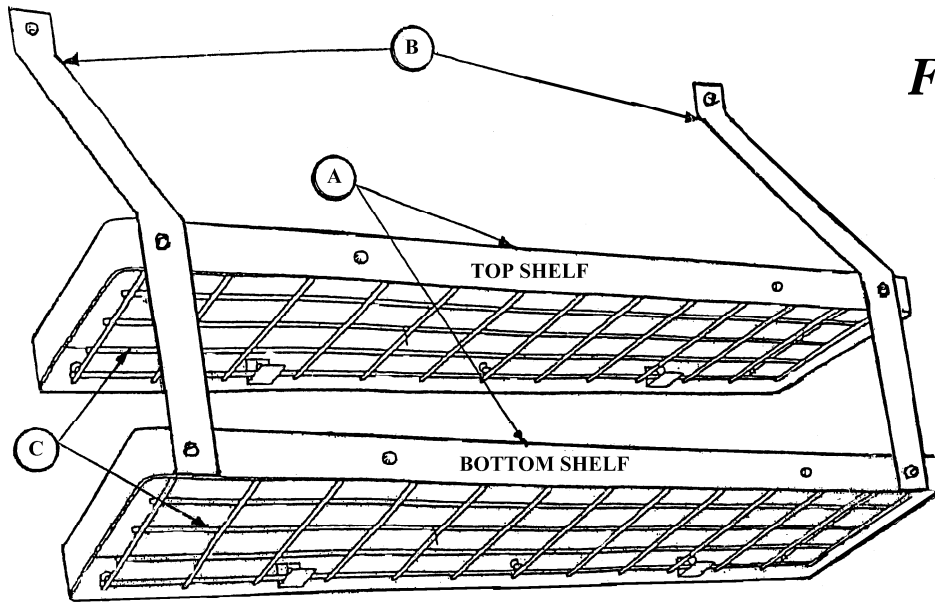

FIGURE 1

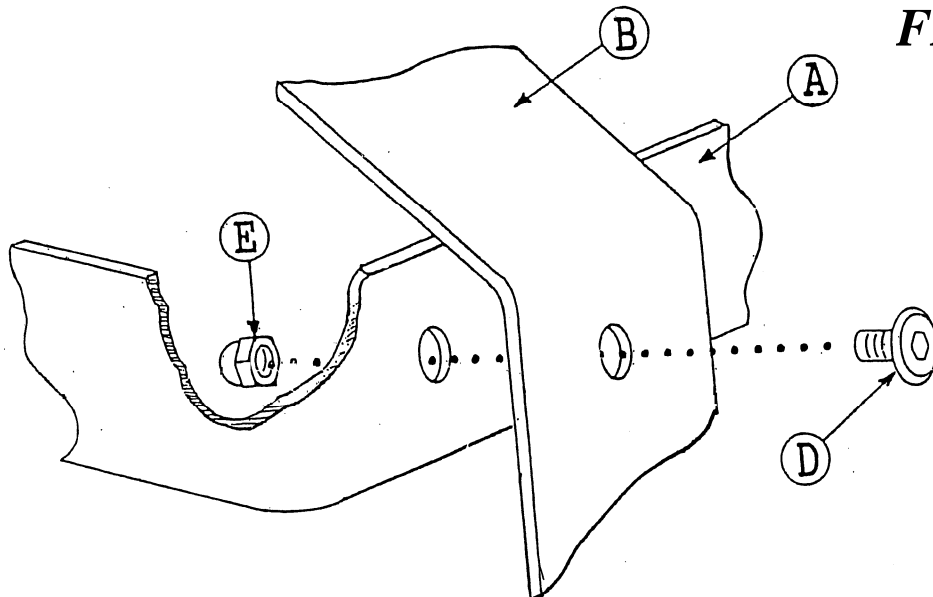

FIGURE 2

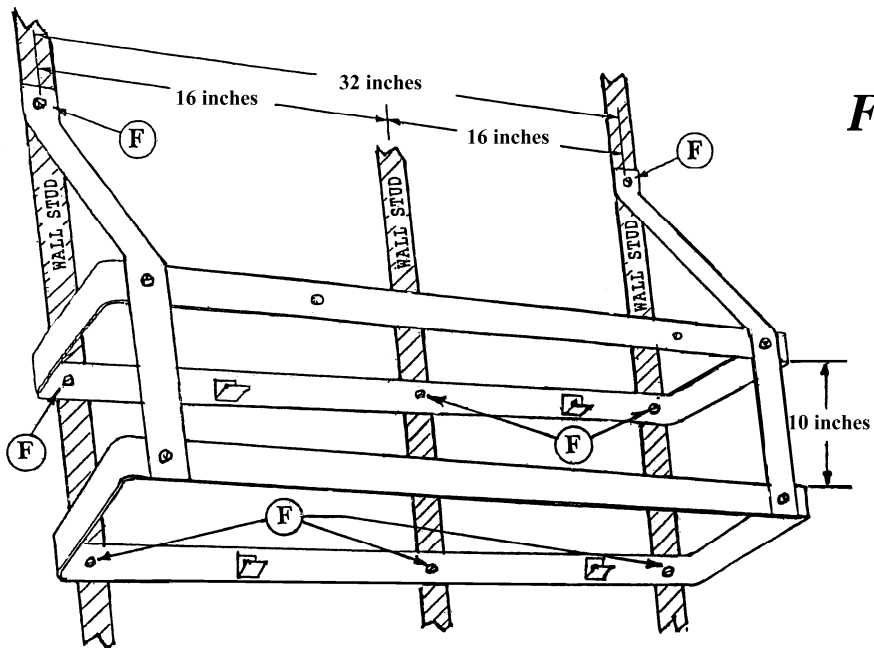

FIGURE 3