

pendants



**Weblink**  
100

**Project page**  
262, 324, 336, 342, 354, 368, 372, 376

**Design**  
Poul Henningsen

**Concept**  
PH ke (1958) is a 360-degree glare free luminaire created by 72 leaves, which shield the light source, redirect and reflect the light onto the underlying leaves, giving distinct, unique illumination.

**Finish**  
Copper or stainless steel, brushed and lacquered. White, wet painted.

**Material**  
Leaves: Die cut copper, laser cut stainless steel or die cut steel. Top shade: White, spun steel. Frame: High lustre chrome plated, laser cut steel. Suspension: High lustre chrome plated, spun aluminum.

**Mounting**  
Suspension type: 3x stainless steel aircraft cables. Suspension length: 12'. Canopy: White. Cord type: 3-conductor, 18 AWG PVC power cord. Cord color: Copper version: Black cord or stainless steel and white version: white cord. Cord length: 12'.

**Weight**  
Max. 55 lbs.

**Label**  
cUL, Dry location. IBEW.

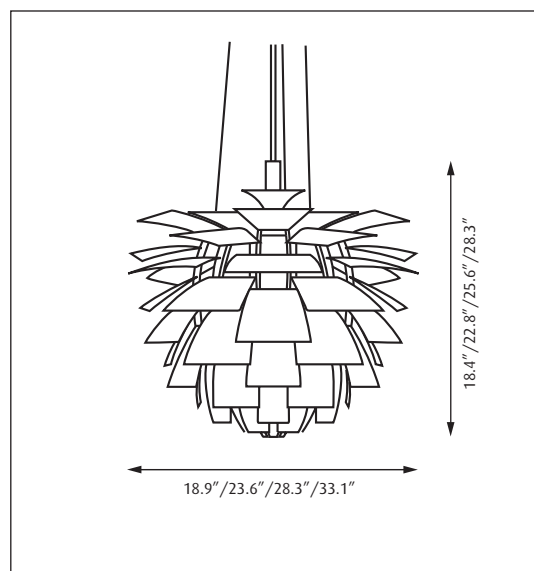

Product code	Dimension	Light source	Voltage	Finish
PHA	18.9" 23.6" 28.3" 33.1"	1/150W/CMH/T-6 G12 1/250W/MH/ED-28-0 mogul 1/400W/MH/ED-37 mogul 1/200W/A-23/CL medium 1/500W/PS-35/CL mogul	120/277V 120V	BR ST STEEL COP LAC WHT

Specification notes:

- 18.9" variant is available in 1/200W incandescent and CMH G12 light sources.
- CMH and MH variants provided with one remote mounted 120/277V F-can ballast.
- Incandescent variants only available in 120V.
- MH variants require an open rated lamp (by others)
- 1/400W/ED-37/MH mogul is not available in 23.6" or 18.9" diameter variants.
- 23.6", 28.3", 33.1" variants are only available in 1/500W incandescent.

Info notes:

- MH variants require an open rated lamp (by others).
- The comparable EU version has the following classification: Ingress Protection Code: IP20.



White

Copper

Stainless steel

White

Copper

Stainless steel

**Tampa International Airport**  
Tampa, Florida, USA  
**Architect**  
Alfonso Architects, Inc.  
**Lighting Designer**  
Tilden Lobnitz Cooper  
**Photo**  
Terry Renna

