

ASSEMBLY INSTRUCTIONS
MODEL 5302

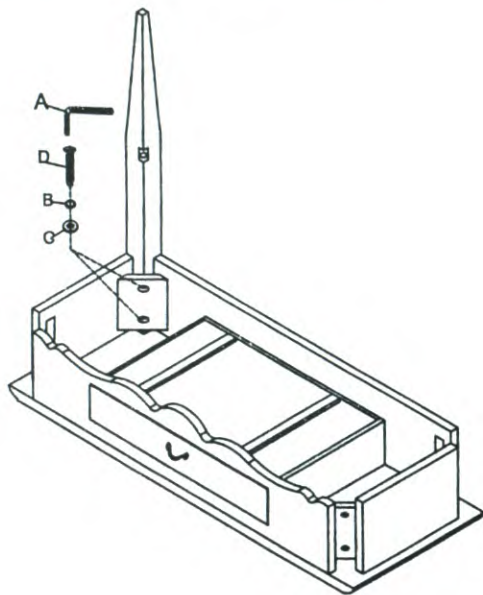

HARDWARE LIST & PARTS LIST

NO	DRAWING	DESCRIPTION	QTY
A		Allen wrench	01
B		Spring washer	12
C		Flat washer	12
D		Long allen bolt	08
E		Short allen bolt	04

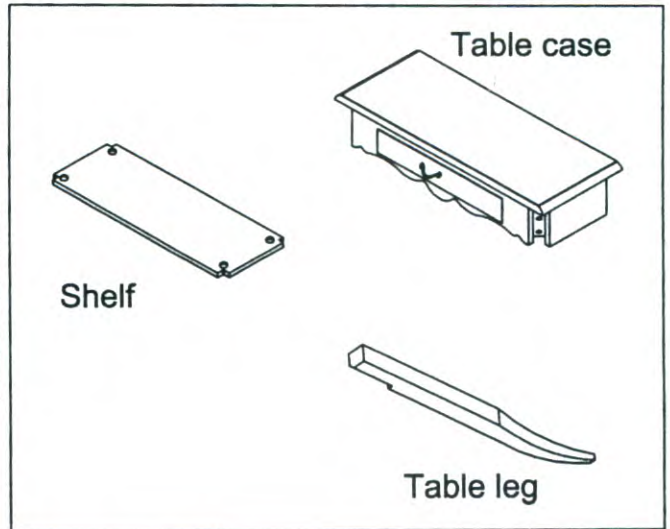

Step 1

Place the table case on a clean surface and then attach the table leg. Secure by using allen wrench (A), long allen bolt (D), spring washer (B) and flat washer (C). Do not tighten until legs are attached.

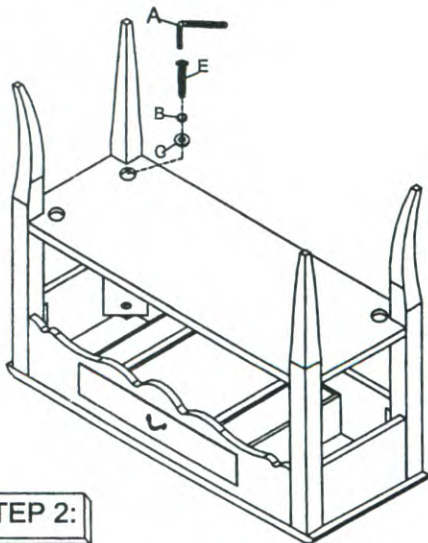

STEP 2:

Attach the shelf to the legs as shown. Secure by using allen wrench (A), short allen bolt (E), spring washer (B) and flat washer (C). Tighten all screws.



Assembly is complete