

Assembly Diagram

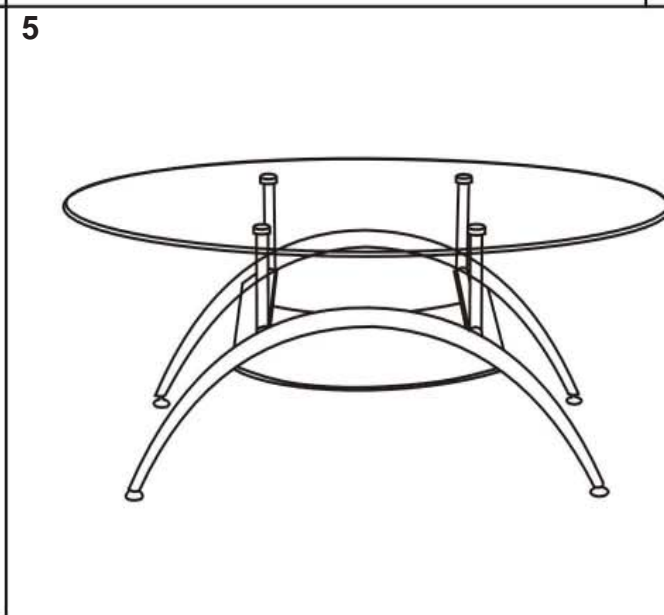

MODEL NO:C42BM

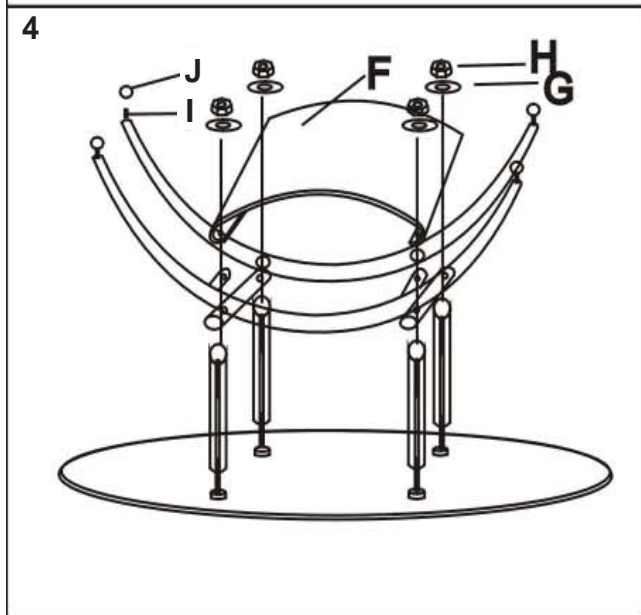
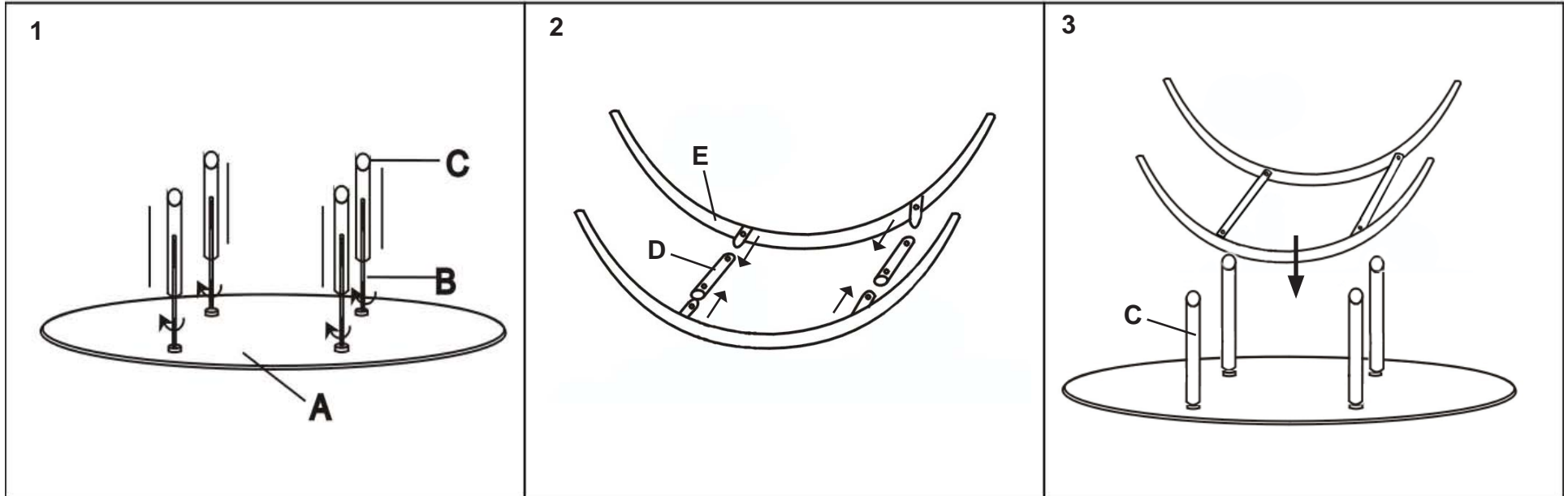

| | | | |
|----------|--|-------------|----------|
| A | | Top Glass | 1 |
| B | | 7" Rod | 4 |
| C | | Cylinder | 4 |
| D | | Cross Bar | 2 |
| E | | Curved Legs | 2 |
| F | | Mesh | 1 |
| G | | Washer | 4 |
| H | | Nuts | 4 |
| I | | Rod(xs) | 4 |
| J | | Feet | 4 |

Assembly Instruction

C42BM



*Important: Make sure all parts are available for assembly
Follow Instructions steps very carefully*

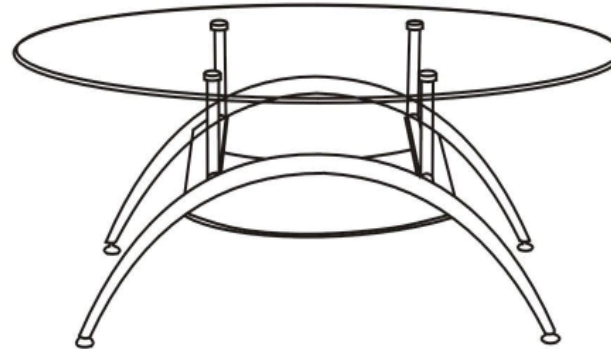

Step 1: Lay large table glass (A) on soft surface

Screw rods (B) into the four plates on the glass and slide cylinders (C) over the rods.

Step 2: Insert curved legs (E) into cross bars (D) as shown in the illustration and align the holes properly.

Step 3: Place leg assembly over rods (B). Ensure the cross bars (D) are seated properly in the groove of the rods.

Step 4: Place mesh basket (F) over rods (B). Place washers (G) and nuts (N) over rods (B) and tighten.

Screw feet (J) unto all four rods (I). Screw foot assemblies to curved legs (D) as shown in the illustration.

Warning: *Be careful to not over tighten*

Step 5: Very carefully turn the table upright

For our most up to date instruction, to request missing, lost, or broken parts, or for any other Customer Service issues, please visit our website at www.walkerredison.com or call us at 877-203-2917.