

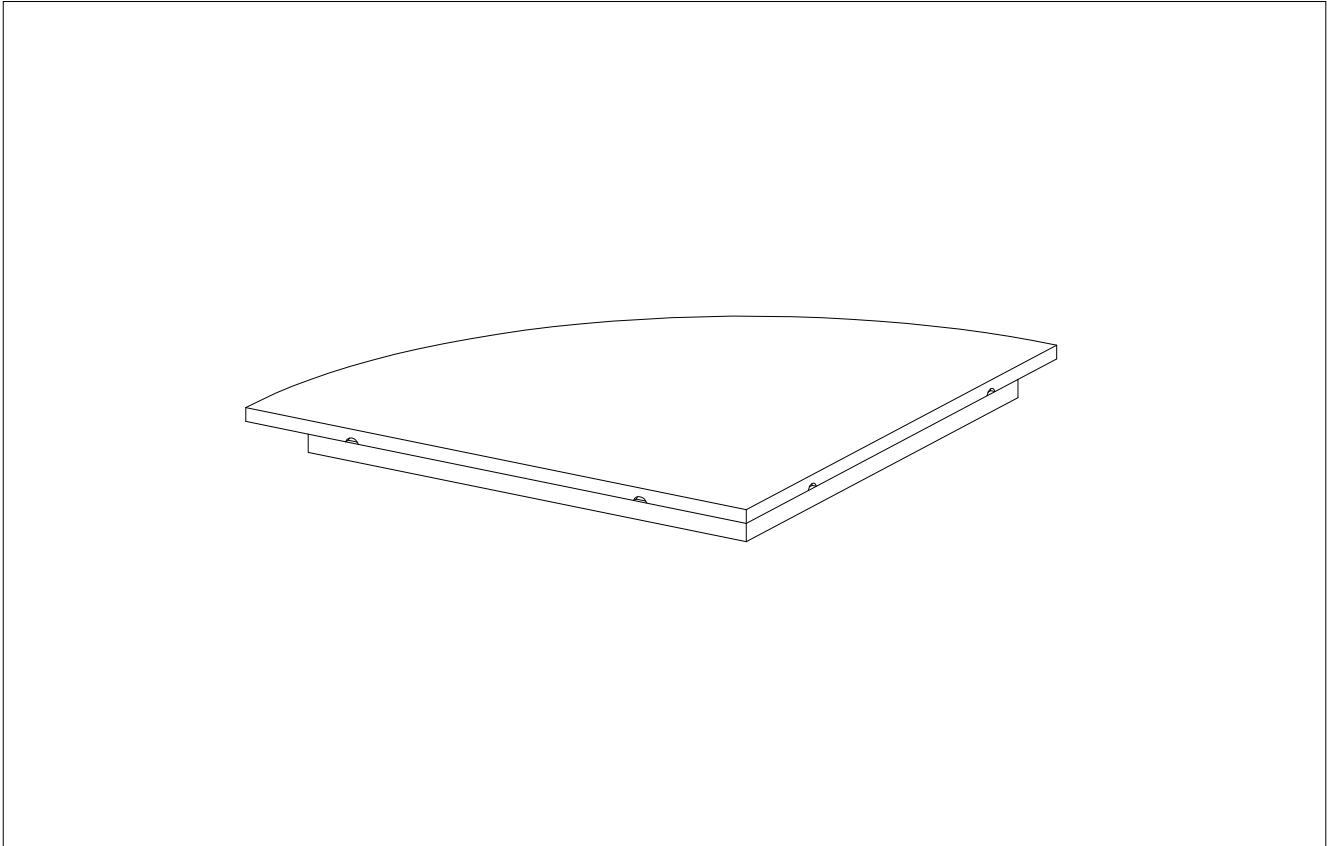

## **Florentina Corner Connector**

**ZLN # ZL2160-3CCU**



 **DO NOT return to the store if parts are missing or damaged.**

For Parts Replacements and Inquiries, please call us Toll-Free 1-888-736-2141 or E-mail  
[CustomerService@Z-LineDesigns.com](mailto:CustomerService@Z-LineDesigns.com)

To ensure a timely delivery, please include the following:

1. Full Name
2. Physical Address (Our primary carrier, FedEx, will NOT deliver to P.O. Boxes)
3. Phone Number
4. QC Number : SW
5. ZLN Number : ZL2160-3CCU\_V00
6. Part Number(s) or Letter(s)
7. Quantity
8. We also request that you please provide a brief description of the reason for your request.

**Our Customer Service Representatives will be available to assist you Monday – Friday 7:00 am to 3:30 pm  
Pacific Standard Time (Except Holidays).**

082112

## ***Important***



ONLY ONE PERSON IS NECESSARY FOR THE ASSEMBLY OF THIS PRODUCT.  
HOWEVER ONE OR MORE STEPS MAY NEED A SECOND PERSON TO ASSIST.

---

**Before you begin:** Lay out all of the parts on a non-abrasive surface in order to identify and count prior to assembly. You will need the parts and hardware listed on page 3 of this instruction manual.

---

**NOW YOU ARE READY TO BEGIN ACTUAL ASSEMBLY!**

**WARNING – Failure to follow these installation instructions or any other abuse, mistreatment, unreasonable use or neglect of the product shall constitute a waiver of all warranties, expressed and implied, and constitute a waiver of all claims of liability against Z-Lines Designs, Inc., its directors, officers, shareholders, parents, subsidiaries, affiliates, agents, customers and licensors, for any direct, indirect, special (including loss of revenue or income, pain and suffering, emotional distress, or similar damages), incidental, punitive, or consequential damages arising out of or resulting from the improper installation, abuse, mistreatment, unreasonable use or neglect regardless of whether such damages arise in contract, tort, under statute, in equity, at law, or otherwise.**

# PARTS IDENTIFICATION

1

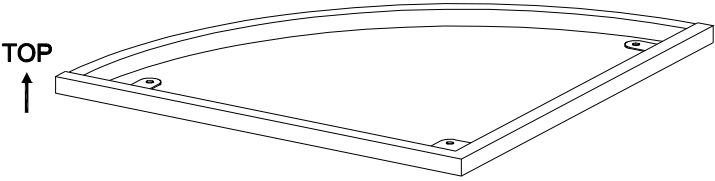

CORNER FRAME

1 PC

2

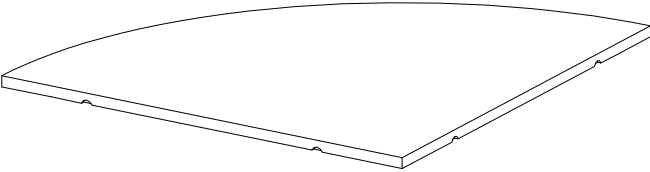

CORNER WOOD PANEL

1 PC

# HARDWARE IDENTIFICATION

A

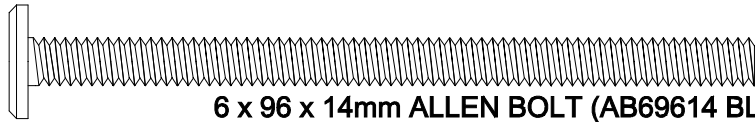
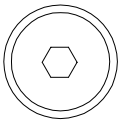

6 x 96 x 14mm ALLEN BOLT (AB69614 BL)

4 PCS

B

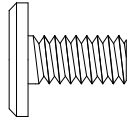
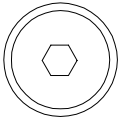

6 x 13 x 14mm ALLEN BOLT (AB61314 BL)

3 PCS

C

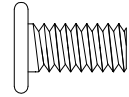

6 x 13 x 10mm ALLEN BOLT (AB61310 BL)

4 PCS

D



METAL BRACKET

4 PCS

E

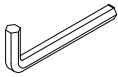

ALLEN WRENCH (AW4S)

1 PC

THE BELOW PARTS ARE PRE-ASSEMBLED AND ARE LISTED AS A REFERENCE ONLY.

ZA



END CAP

2 PCS

# ASSEMBLY INSTRUCTION

## STEP 1

PLEASE DECIDE THE ORIENTATION OF THE ZL2160-1MDU MAIN DESK and ZL2160-2CDU COMPUTER DESK BEFORE PROCEEDING WITH THIS STEP.

\*Note: The ZL2160-2CDU Computer Desk can be installed on either the Right or Left Side of the ZL2160-1MDU Main Desk.

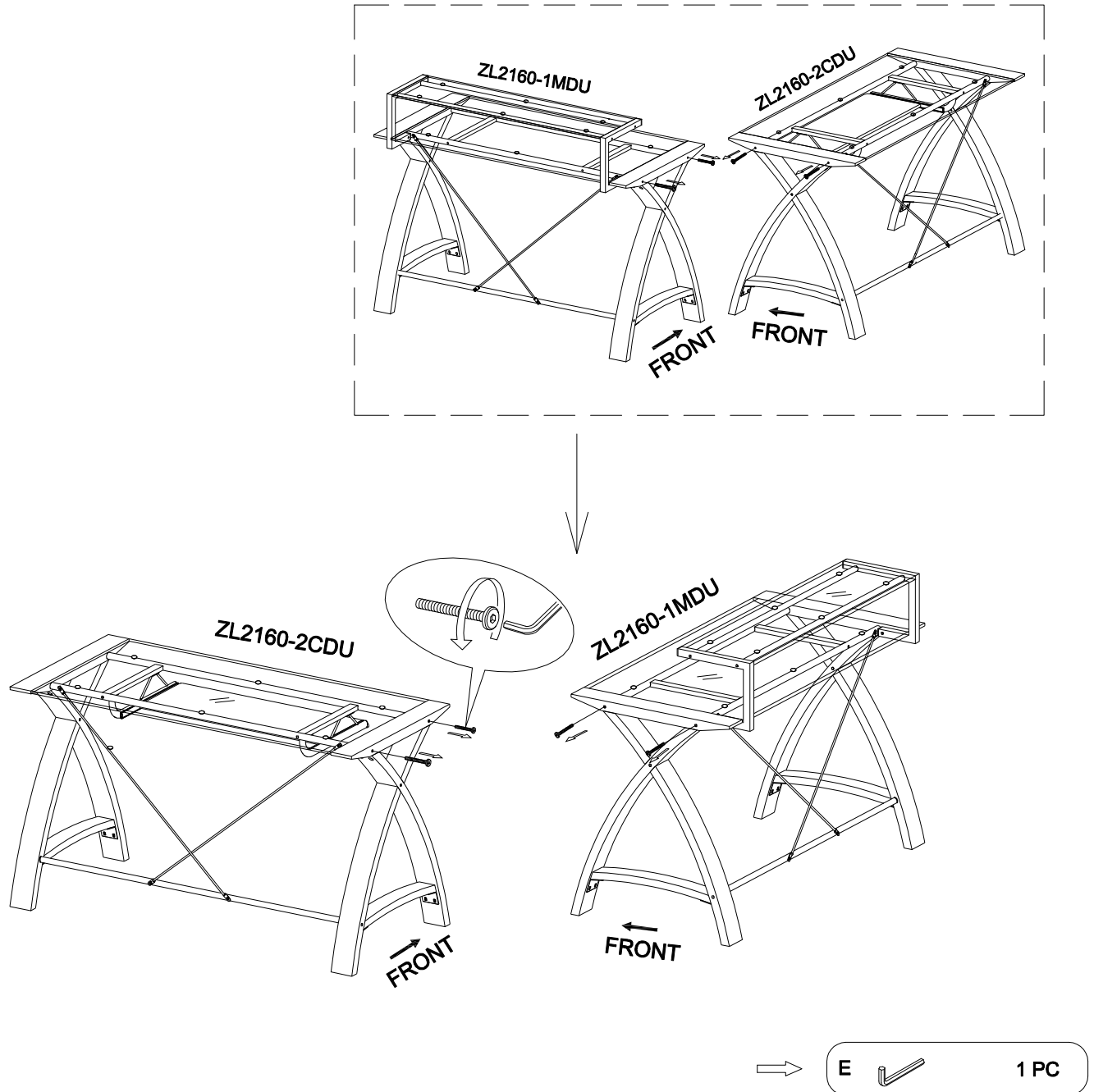

**\*NOTE:** It is **STRONGLY RECOMMENDED** that you remove the Top Glass from both the ZL2160-1MDU Main Desk and ZL2160-2CDU Computer Desk before proceeding with this step. Alternatively, have someone help support the Top Glass while you remove original Allen Bolts.

Remove original Allen Bolts from the FRONT and BACK corresponding side frames of ZL2160-1MD and ZL2160-2CDU using (E) Allen Wrench. You may discard the OLD Allen Bolts at this time.

# STEP 2

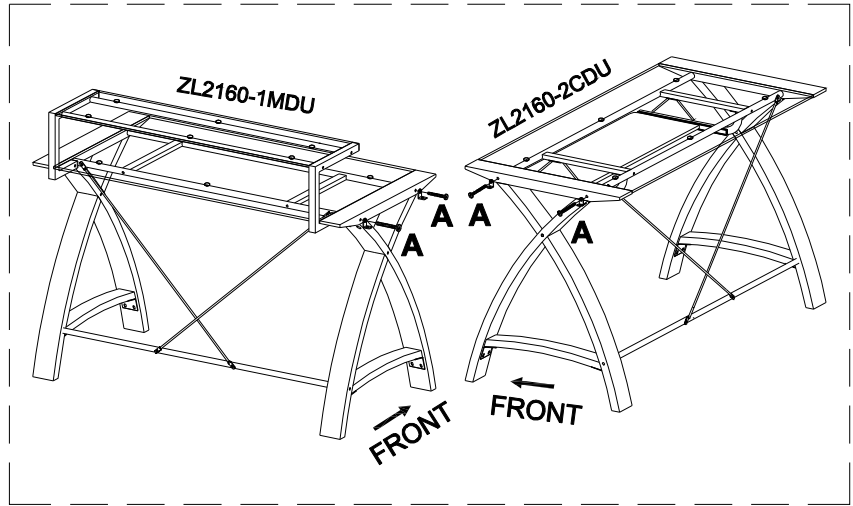

DO NOT FULLY TIGHTEN ALLEN BOLTS UNTIL THE END OF STEP 4.

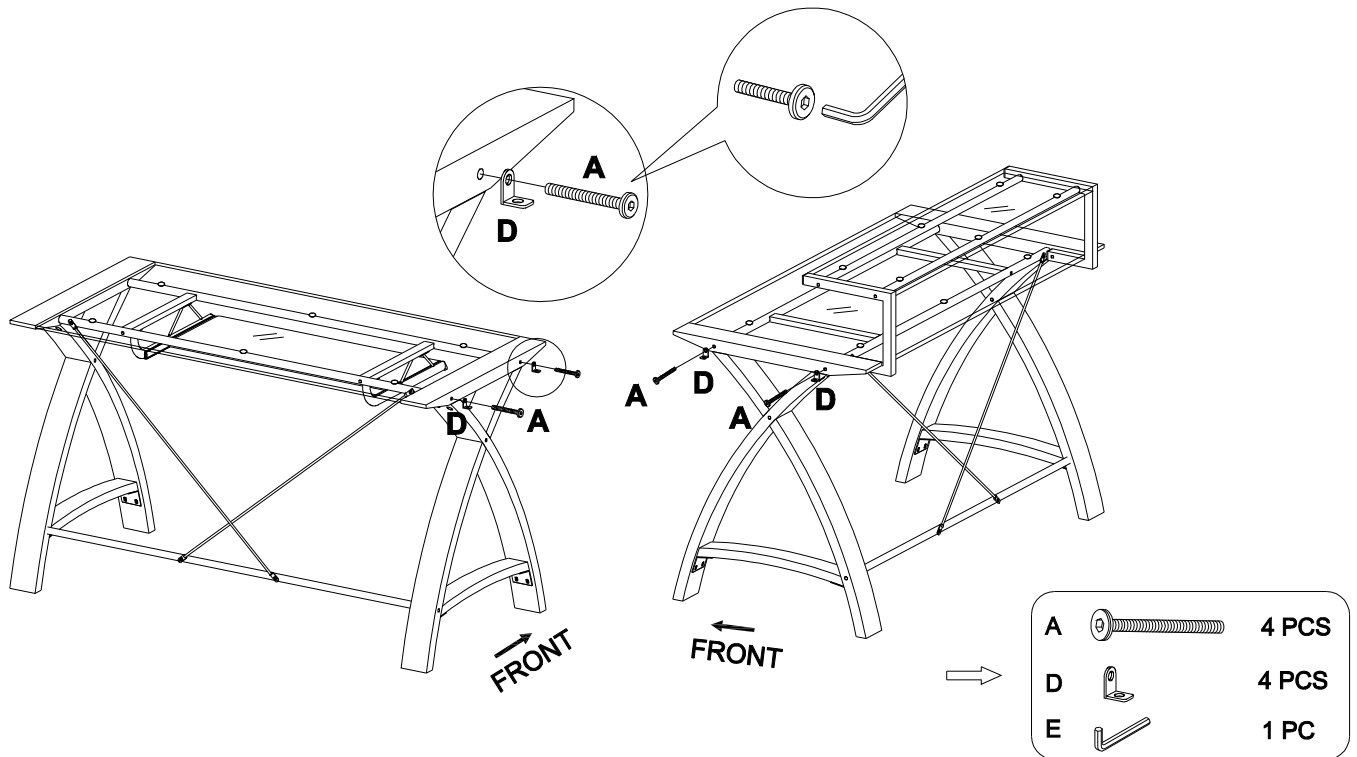

# STEP 3

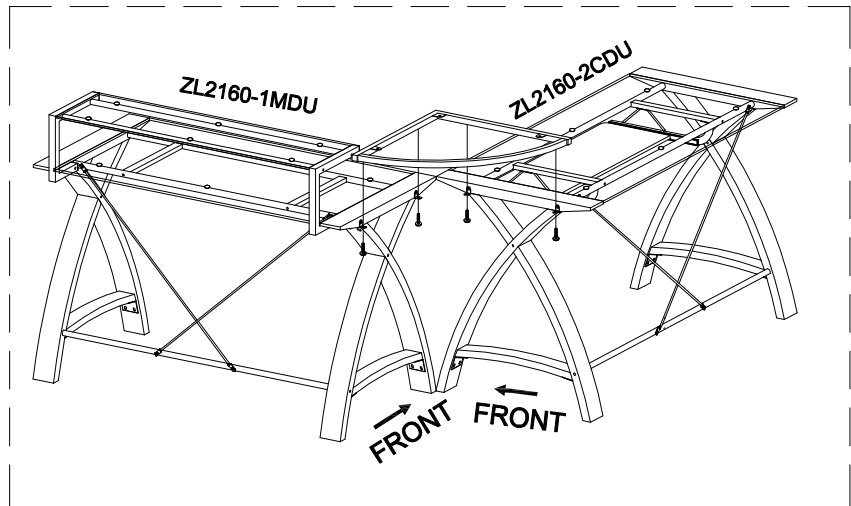

DO NOT FULLY TIGHTEN ALLEN BOLTS UNTIL THE END OF STEP 4.

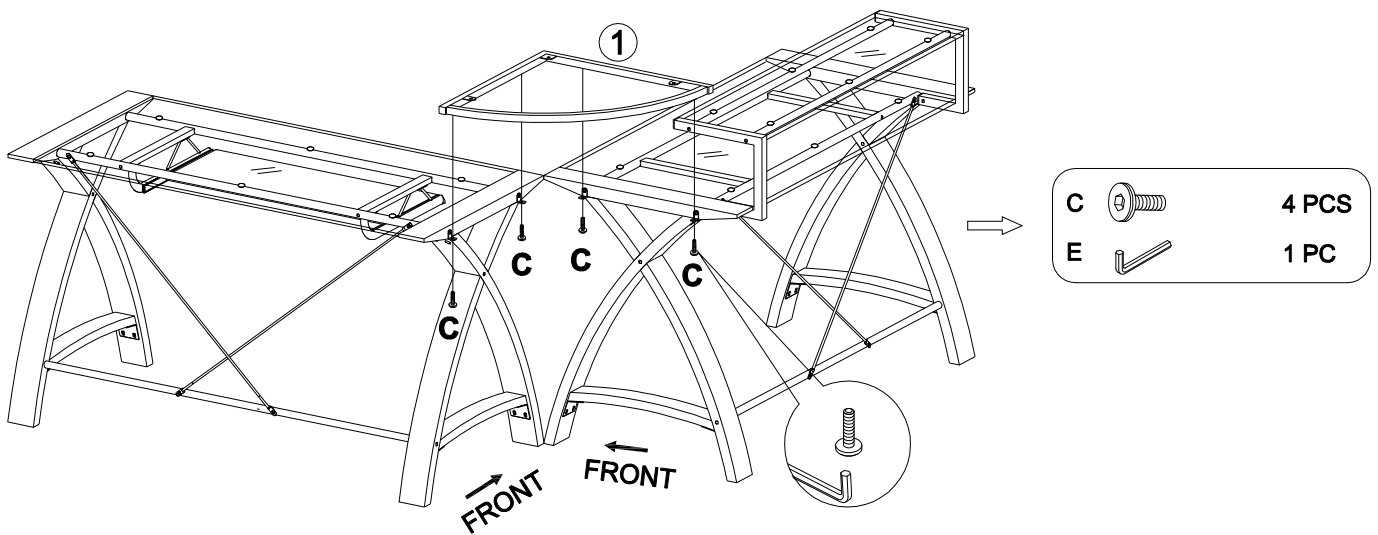

# STEP 4

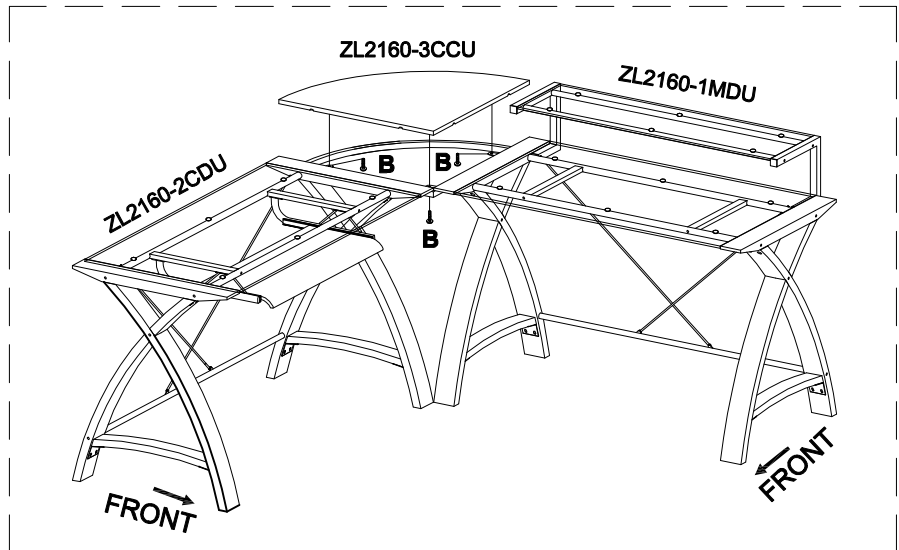

FULLY TIGHTEN ALLEN BOLTS FROM STEPS 2-4 AT THIS TIME USING (E) ALLEN WRENCH.

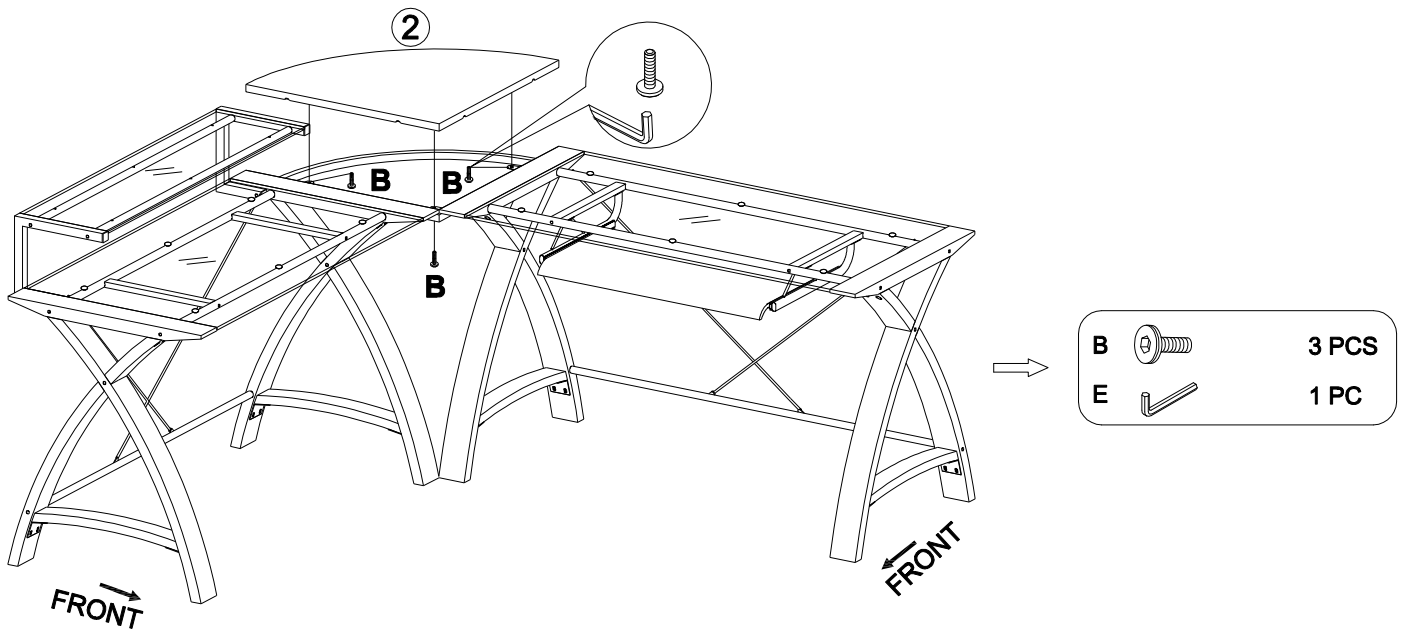

## DIMENSIONS

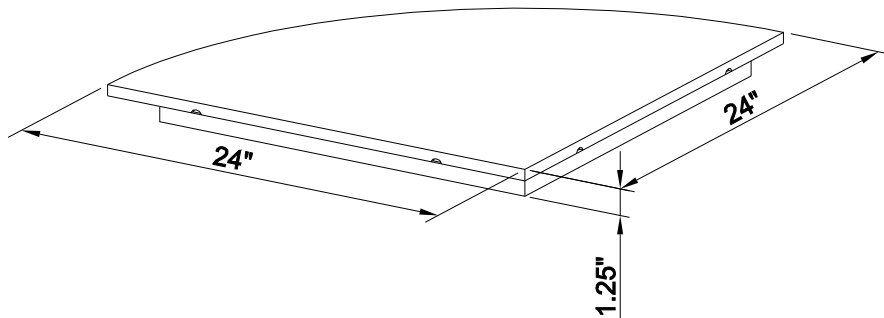

Product Size: 24" (W) x 24" (D) x 1.25" (H)

## MAXIMUM WEIGHT CAPACITIES

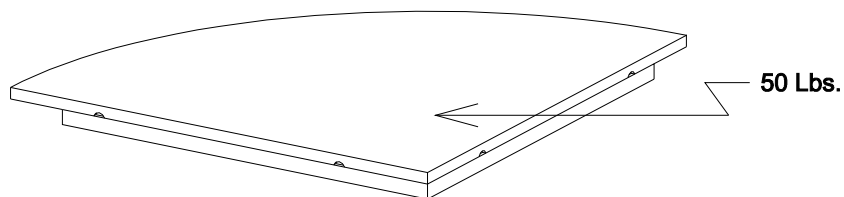

**⚠ WARNING: THIS PRODUCT IS INTENDED TO HOLD THE MAXIMUM WEIGHT (EVENLY DISTRIBUTED) INDICATED. EXCEEDING THE MAXIMUM WEIGHT WILL RESULT IN INSTABILITY AND MAY CAUSE POSSIBLE INJURY.**





Creating beauty, Manufacturing great value!



## 1 Year Limited Warranty

Thank you for purchasing a Z-Line Designs product. We promise to repair or replace any Z-Line Designs product or component that may have any defects in material or workmanship for as long as you, the original purchaser, own it. This warranty is subject to the provisions below. Z-Line Designs' sole obligation and purchasers' exclusive remedy pursuant to these warranties are limited to replacement at Z-Line Designs sole discretion. There are no other warranties except as expressly set forth below, either expressed or implied, including any warranty of merchantability for any particular purpose.

The word "defects" in this warranty is defined as imperfections that impair the service, function or effectiveness of the product.

### 1 YEAR:

Glides, casters and user-adjustable work surface mechanisms, laminates, veneer finishes and other materials which cover your Z-Line Designs product.

### INFORMATION ON COLOR VARIATIONS & FINISHES:

Some natural variations occurring in wood, or other natural materials are inherent to their character, and thus can not be avoided. Therefore they are not considered to be defects. Z-Line Designs does not warrant the color-fastness or matching of colors, grains, textures or other such materials. Customers' own materials selected by and used at the request of a user is therefore not warranted by Z-Line Designs.

### LIMITATIONS INVOLVING MATERIALS & COMPONENTS:

The materials and all components listed below are covered according to the following schedule from the date of sale to the original purchaser.

### EXCLUSIONS:

This warranty does not apply to: damage caused by the carrier, modifications to the product, or attachments to the product not approved by Z-Line Designs, non-standard materials selected by and used at the request of a user, and products that were not installed, used or maintained in accordance with product instructions and warnings. Nor shall Z-Line Designs have any responsibility for incidental or consequential damages resulting from the breach of this Warranty, including but not limited to inconvenience, rental or purchase of replacement products, loss of profits or commercial loss. Some states do not allow the exclusion or limitation of incidental or consequential damages so the above limitation or exclusion may not apply to you. This warranty gives you specific legal rights and you may also have other rights, which may vary from state to state. This warranty applies only to products sold within the United States of America and the Commonwealth of Canada.

### TO OBTAIN SERVICE FROM THIS WARRANTY:

Your Z-Line Designs' dealer is our mutual partner in supporting your warranty requests. By following the procedures instructed below, you are assured that you will receive the best level of customer service guaranteed.

- A) Please contact the local Dealer from whom you originally purchased within 30 days (**unless otherwise noted by the Dealer**) of discovery of the defect. Prepare to confirm that you are the original purchaser of the product and provide necessary product information, such as serial number(s)/ UPC number(s) from the product in question.
- B) The Dealer will gather all the pertinent information required regarding your claim(s), inspect the product and thus contact a Z-Line Designs Customer Service Representative. (Please allow a reasonable amount of time for inspection, review, and response to Dealer.
- C) If the Z-Line Designs Dealer confirms that the product in review is eligible under the warranty conditions as stated above, the customer service representative or another representative of the Company will determine whether to provide replacement parts, or authorize other arrangements at the sole discretion of the vendor, Z-Line Designs. No assembly/labor is included in this warranty.

### TO CONTACT CUSTOMER SERVICE:

Our knowledgeable Service Representatives are ready to assist you in the case this warranty applies to you. Please be prepared to explain the defect in detail, model/style number, date and location of purchase, your name, address, phone number and have your original sales receipt.

Please contact us Monday-Friday (except all major holidays) at:

Toll Free 1-888-736-2141 from 7:00 am – 3:30 pm (Pacific Standard Time) OR Email us: [customerservice@z-linedesigns.com](mailto:customerservice@z-linedesigns.com)

**OR**

Contact your local dealer from whom you originally purchased the product in question.





