



## Triana Desk & Bookcase

### ZLN # ZL2031-1DBU



**⚠ DO NOT return to the store if parts are missing or damaged.**

For Parts Replacements and Inquiries, please call us Toll-Free 1-888-736-2141 or E-mail [CustomerService@Z-LineDesigns.com](mailto:CustomerService@Z-LineDesigns.com)

To ensure a timely delivery, please include the following:

1. Full Name
2. Physical Address (Our primary carrier, FedEx, will NOT deliver to P.O. Boxes)
3. Phone Number
4. QC Number : SW
5. ZLN Number : ZL2031-1DBU\_V00
6. Part Number(s) or Letter(s)
7. Quantity
8. We also request that you please provide a brief description of the reason for your request.

**Our Customer Service Representatives will be available to assist you Monday – Friday 7:00 am to 3:30 pm Pacific Standard Time (Except Holidays).**

062812

## ***Important***

**Estimated Assembly Time: 50 Min.**



TWO PEOPLE ARE NECESSARY FOR THE ASSEMBLY OF THIS PRODUCT.

---

**Before you begin:** Lay out all of the parts on a non-abrasive surface in order to identify and count prior to assembly. You will need the parts and hardware listed on pages 3 - 5 of this instruction manual as well as the tools shown below to assemble this unit.

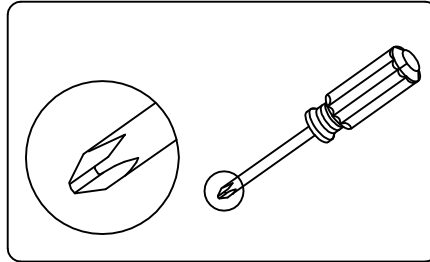











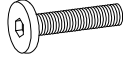
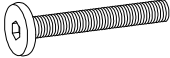
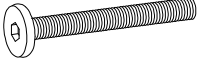
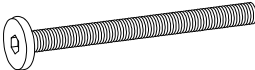

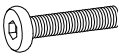
PHILLIPS HEAD SCREWDRIVER

---

**NOW YOU ARE READY TO BEGIN ACTUAL ASSEMBLY!**

**WARNING – Failure to follow these installation instructions or any other abuse, mistreatment, unreasonable use or neglect of the product shall constitute a waiver of all warranties, expressed and implied, and constitute a waiver of all claims of liability against Z-Lines Designs, Inc., its directors, officers, shareholders, parents, subsidiaries, affiliates, agents, customers and licensors, for any direct, indirect, special (including loss of revenue or income, pain and suffering, emotional distress, or similar damages), incidental, punitive, or consequential damages arising out of or resulting from the improper installation, abuse, mistreatment, unreasonable use or neglect regardless of whether such damages arise in contract, tort, under statute, in equity, at law, or otherwise.**

## HARDWARE IDENTIFICATION









A		6 x 38 x 14mm ALLEN BOLT (AB63814BL)	2 PCS
B		6 x 64 x 14mm ALLEN BOLT (AB66414BL)	12 PCS
C		6 x 76 x 14mm ALLEN BOLT (AB67614BL)	4 PCS
D		6 x 101 x 14mm ALLEN BOLT (AB610114BL)	1 PC
E		6 x 13 x 10mm ALLEN BOLT (AB61310BL)	33 PCS
F		6 x 35 x 10mm ALLEN BOLT (AB63510BL)	4 PCS
G		CAP NUT	1 PC
H		SPACER	5 PCS
I		4 x 12 x 8mm WOOD SCREW (RHWS4128BL)	4 PCS
J		SUCTION CUP	14 PCS
K		ADHESIVE GLASS SUPPORT	8 PCS
L		END CAP	8 PCS
M		FLAT PAD	3 PCS
N		ALLEN WRENCH	1 PC
O		SPANNER WRENCH	1 PC
P		CONNECTOR BRACKET	3 PCS

\*Extra hardware is enclosed for your convenience.

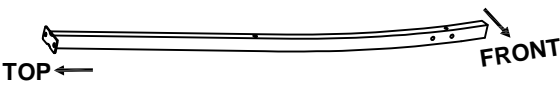

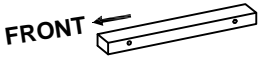
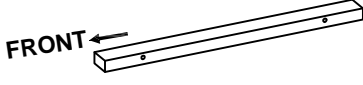
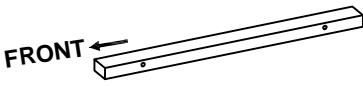

THE BELOW PARTS ARE PRE-ASSEMBLED AND ARE LISTED AS A REFERENCE ONLY.

ZA		UPPER END CAP	3 PCS
ZB		LOWER END CAP	2 PCS

# PARTS IDENTIFICATION-1

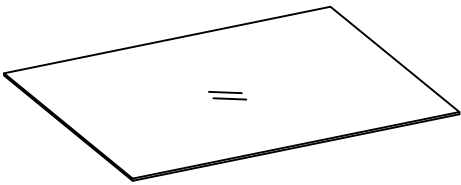
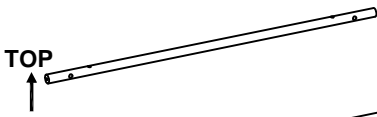
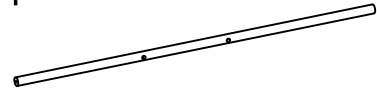
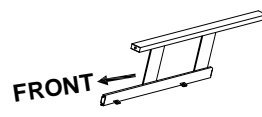
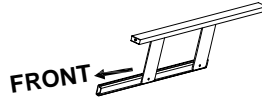
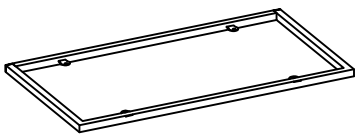
①		LEFT FRONT LEG	1 PC
②		MIDDLE FRONT LEG	1 PC
③		RIGHT FRONT LEG	1 PC
④		LEFT BACK LEG	1 PC
⑤		MIDDLE BACK LEG	1 PC
⑥		RIGHT BACK LEG	1 PC
⑦		TOP SHELF SUPPORT	2 PCS
⑧		MIDDLE DESK SUPPORT	1 PC
⑨		RIGHT DESK SUPPORT	1 PC
⑩		LEFT UPPER CROSSBAR	2 PCS
⑪		LEFT MIDDLE SUPPORT TUBE	2 PCS
⑫		LEFT LOWER SUPPORT TUBE	2 PCS
⑬		SHELF CROSSBAR	4 PCS

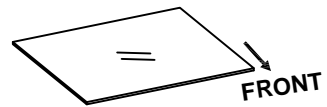
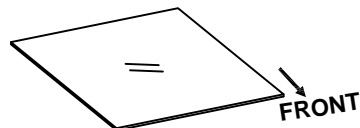
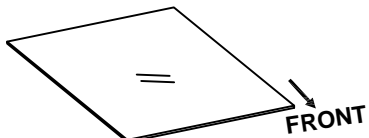
## PARTS IDENTIFICATION-2

14		LOWER SUPPORT TUBE	3 PCS
15		DESKTOP GLASS	1 PC
16		DESK UPPER CROSSBAR	2 PCS
17		DESK LOWER CROSSBAR	1 PC
18		LEFT GLIDE	1 PC
19		RIGHT GLIDE	1 PC
20		KEYBOARD SHELF	1 PC
21		TENSION BAR	2 PCS
22		LEFT UPPER GLASS	1 PC
23		LEFT MIDDLE GLASS	1 PC
24		LEFT LOWER GLASS	1 PC
25		KEYBOARD GLASS	1 PC

# ASSEMBLY INSTRUCTION

## STEP 1

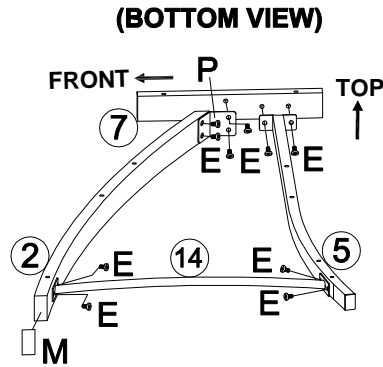
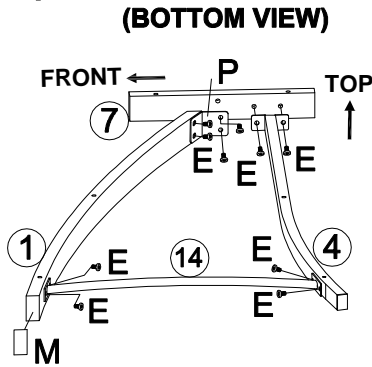

E		20 PCS
P		2 PCS
M		2 PCS
N		

(BOTTOM VIEW)

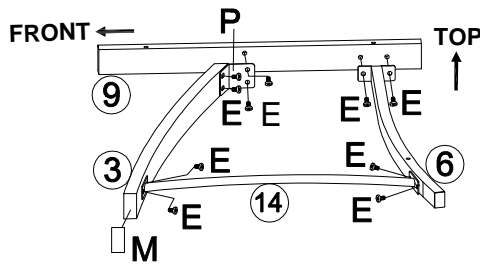

E		10 PCS
P		1 PC
M		1 PC
N		

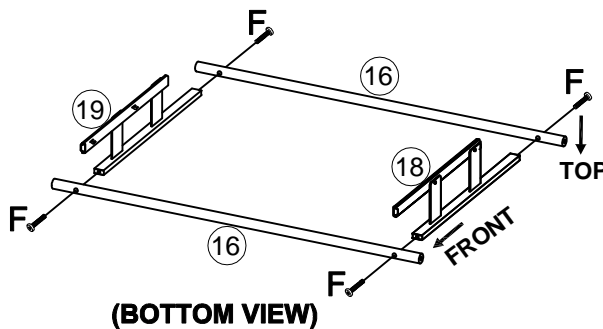

F		4 PCS
N		

### DO NOT FULLY TIGHTEN ALLEN BOLTS UNTIL THE END OF STEP 7.

1. Assemble (1) Left Front Leg and (4) Left Back Leg to (7) Top Shelf Support and (14) Lower Support Tube as shown. Connect (1) Left Front leg using (P) Connector Bracket and secure it and all other components with (E) 6 x 13 x 10mm Allen Bolts and (N) Allen Wrench.
2. Next, apply (M) Flat Pad to the BOTTOM of (1) Left Front Leg assembly as shown.
3. Assemble (2) Middle Front Leg and (5) Middle Back Leg to (7) Top Shelf Support and (14) Lower Support Tube as shown. Connect (2) Middle Front leg using (P) Connector Bracket and secure it and all other components with (E) 6 x 13 x 10mm Allen Bolts and (N) Allen Wrench.
4. Next, apply (M) Flat Pad to the BOTTOM of (2) Middle Front Leg as shown.
5. Assemble (3) Right Front Leg and (6) Right Back Leg to (9) Right Desk Support and (14) Lower Support Tube as shown. Connect (3) Right Front leg using (P) Connector Bracket and secure it and all other components with (E) 6 x 13 x 10mm Allen Bolts and (N) Allen Wrench.
6. Lastly, attach (18) Left Glide and (19) Right Glide to both (16) Desk Upper Crossbars as shown. Secure using (F) 6 x 35 x 10mm Allen Bolts and (N) Allen Wrench.

**\*NOTE: Make sure that both (18/19) Left/Right Glides OPEN to the indicated FRONT of the assembly as shown.**

Set (16) Desk Upper Crossbar assembly aside until Step 4.

## STEP 2

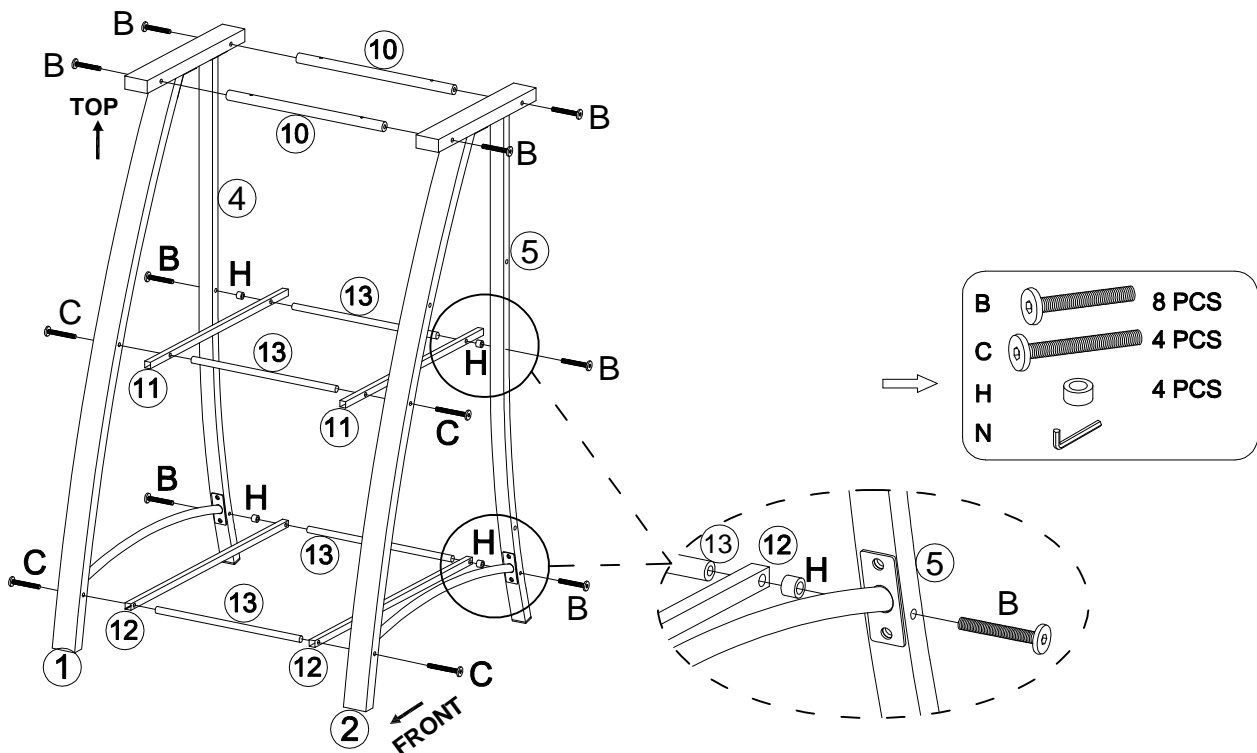

### DO NOT FULLY TIGHTEN ALLEN BOLTS UNTIL THE END OF STEP 7.

1. Attach (1/4) Left Front/Back Leg and (2/5) Middle Front/Back Leg assemblies together as shown. First secure the TOP using (10) Left Upper Crossbars and (B) 6 x 64 x 14mm Allen Bolts and (N) Allen Wrench.
2. Next, secure the MIDDLE portion of the leg assemblies using (11) Left Middle Support tubes and (13) Shelf Crossbars as shown. Secure the FRONT using (C) 6 x 76 x 14mm Allen Bolts and (N) Allen Wrench; then secure the BACK using (H) Spacers (from the inside) and (B) 6 x 64 x 14mm Allen Bolts and (N) Allen Wrench.
3. Lastly, secure the LOWER portion of the leg assemblies using (12) Left Lower Support Tubes and (13) Shelf Crossbars as shown. Secure the FRONT using (C) 6 x 76 x 14mm Allen Bolts and (N) Allen Wrench; then secure the BACK using (H) Spacers (from the inside) and (B) 6 x 64 x 14mm Allen Bolts and (N) Allen Wrench.

## STEP 3

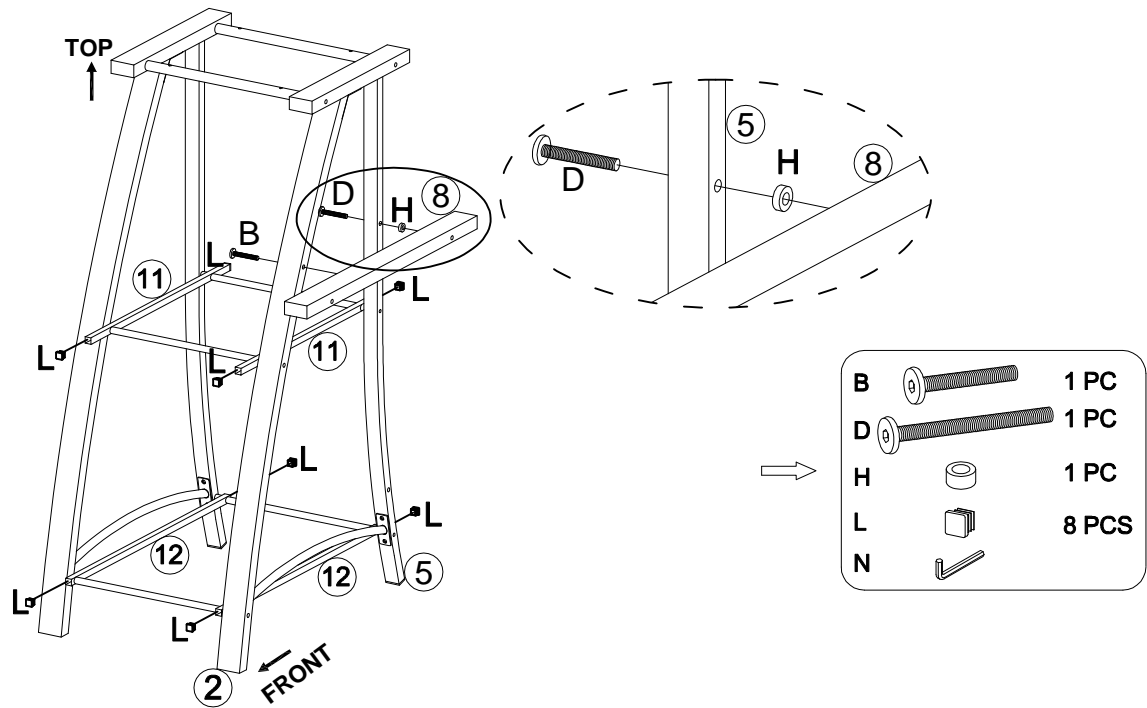

### DO NOT FULLY TIGHTEN ALLEN BOLTS UNTIL THE END OF STEP 7.

1. Install (8) Middle Desk Support to (2/5) Middle Front/Back Leg assembly as shown. Secure the FRONT using (B) 6 x 64 x 14mm Allen Bolt and (N) Allen Wrench; then secure the BACK using (H) Spacer (from the inside) and (D) 6 x 101 x 14mm Allen Bolt and (N) Allen Wrench.

**\*NOTE: (D) 6 x 101 x 14mm Allen Bolt will protrude through (8) Middle Desk Support for use with the next step.**

2. Next, press fit (L) End Caps into place on the FRONT and BACK of both (11) Left Middle Support Tubes and (12) Left Lower Support Tubes as shown.



## STEP 4

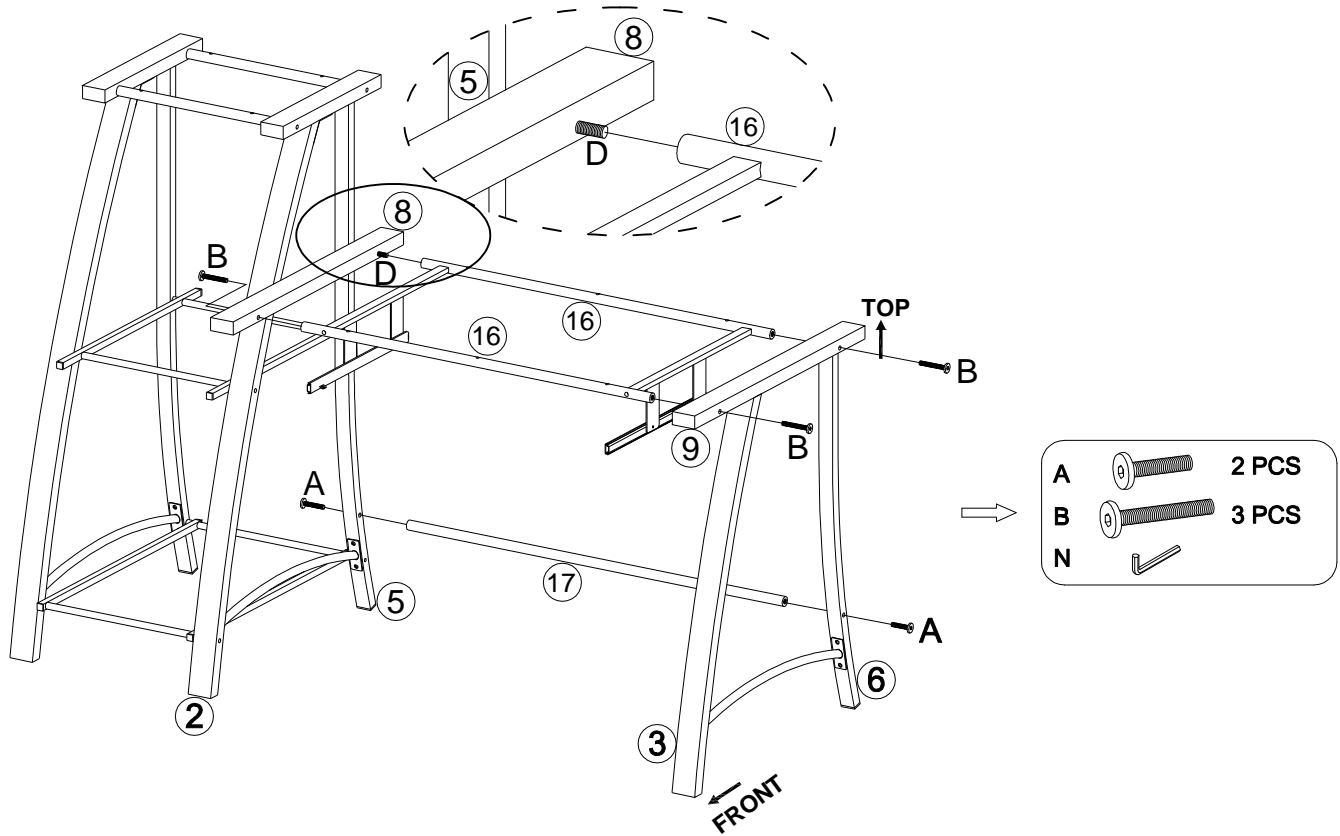

### **DO NOT FULLY TIGHTEN ALLEN BOLTS UNTIL THE END OF STEP 7.**

1. Install (16) Desk Upper Crossbar assembly with glides (from Step 1) to (8) Middle Desk Support assembly and (9) Right Desk Support assembly (from Step 1) as shown. Secure using (B) 6 x 64 x 14mm Allen Bolts; and finish securing (D) 6 x 101 x 14mm Allen Bolts (from Step 3). Tighten with (N) Allen Wrench.
2. Lastly, install (17) Desk Lower Crossbar as shown. Secure using (A) 6 x 38 x 14mm Allen Bolts and (N) Allen Wrench.

**\*NOTE: The 2 (Two) holes at the CENTER of (17) Desk Lower Crossbar--used for installing (21) Tension Bars (in the next step)--should face towards the BACK of the assembly.**

# STEP 5

(BACK VIEW)

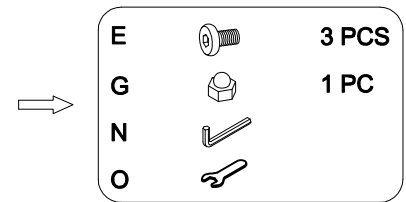
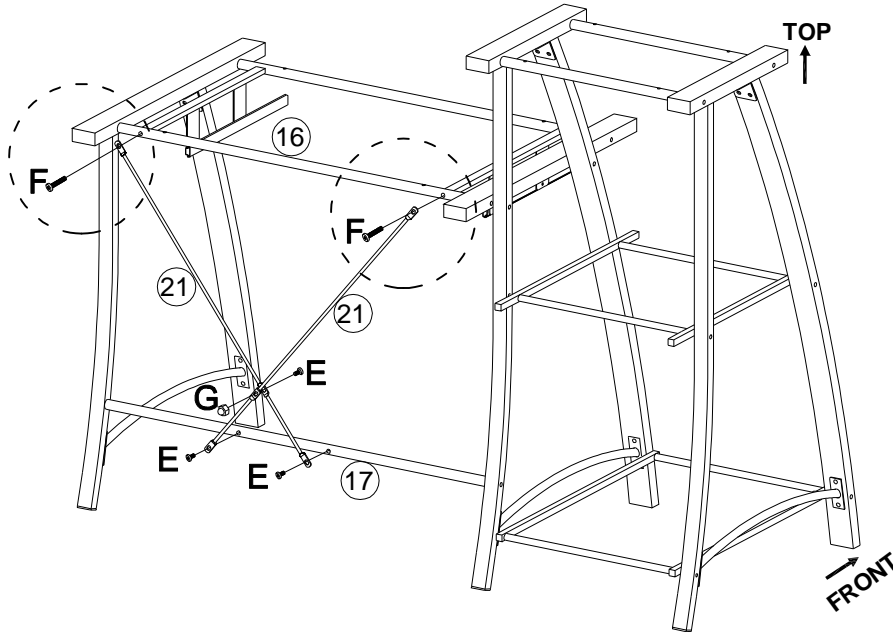

## DO NOT FULLY TIGHTEN ALLEN BOLTS UNTIL THE END OF STEP 7.

1. Remove the BACK set of (F) 6 x 35 x 10mm Allen Bolts temporarily and install (21) Tension Bars into place on (16) Desk Upper Crossbar and (17) Desk Lower Crossbar as shown. Re-secure the TOP using the existing (F) 6 x 35 x 10mm Allen Bolts; then secure the BOTTOM using (E) 6 x 13 x 10 mm Allen Bolts and (N) Allen Wrench.

2. Lastly, secure the MIDDLE of (21) Tension Bars using (G) Cap Nut from the BACK while tightening (E) 6 x 13 x 10mm Allen Bolt from the FRONT using (N) Allen Wrench.

**\*NOTE: Use (O) Spanner Wrench to hold (G) Cap Nut in place while tightening allen bolt.**

## STEP 6

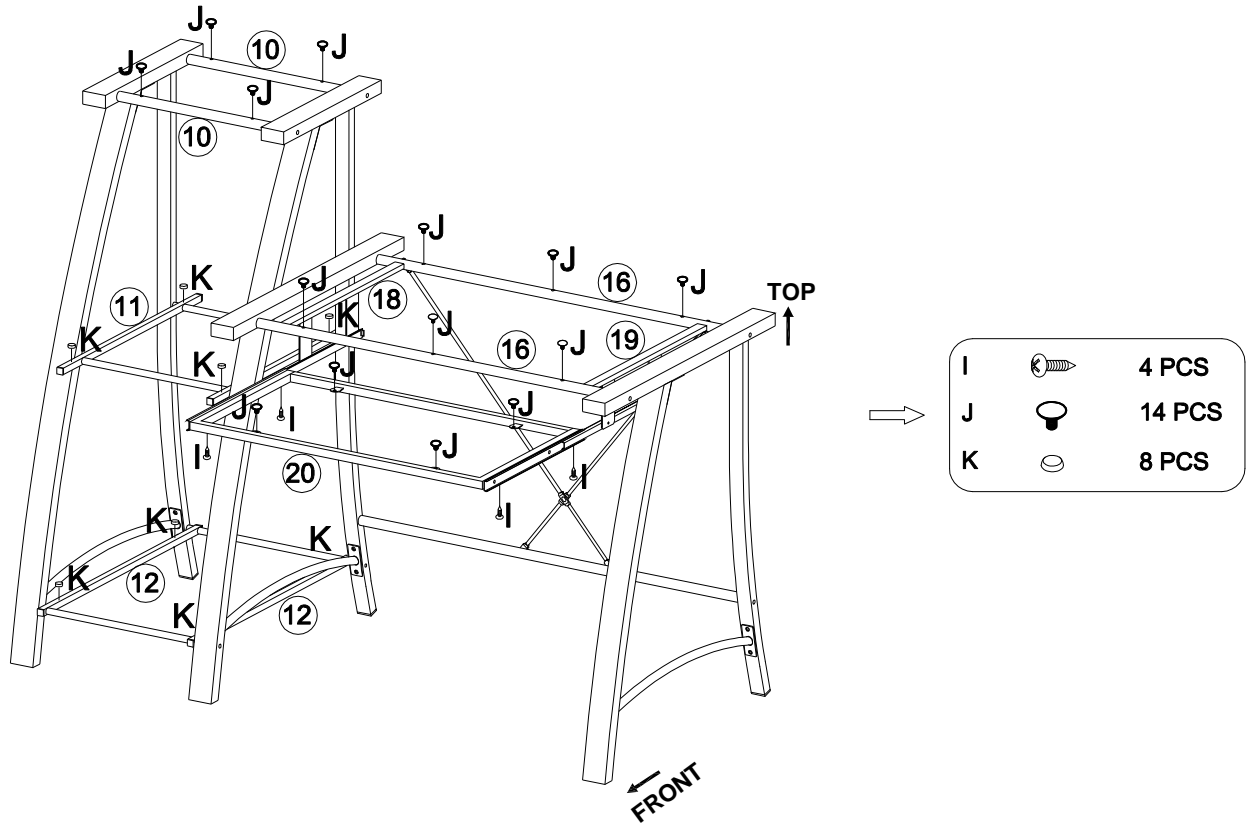

1. Install (20) Keyboard Shelf to (18) Left Glide and (19) Right Glide as shown. Secure from the **BOTTOM** using (I) 4 x 12 x 8mm Wood Screws and a Phillips Head Screwdriver.
2. Next, Install (J) Suction Cups into the corresponding holes on both (10) Left Upper Crossbars, both (16) Desk Upper Crossbars and (20) Keyboard Shelf assembly.
3. Lastly, apply (K) Adhesive Glass Supports to both (11) Left Middle Support Tubes and (12) Left Lower Support Tubes as shown.

## STEP 7

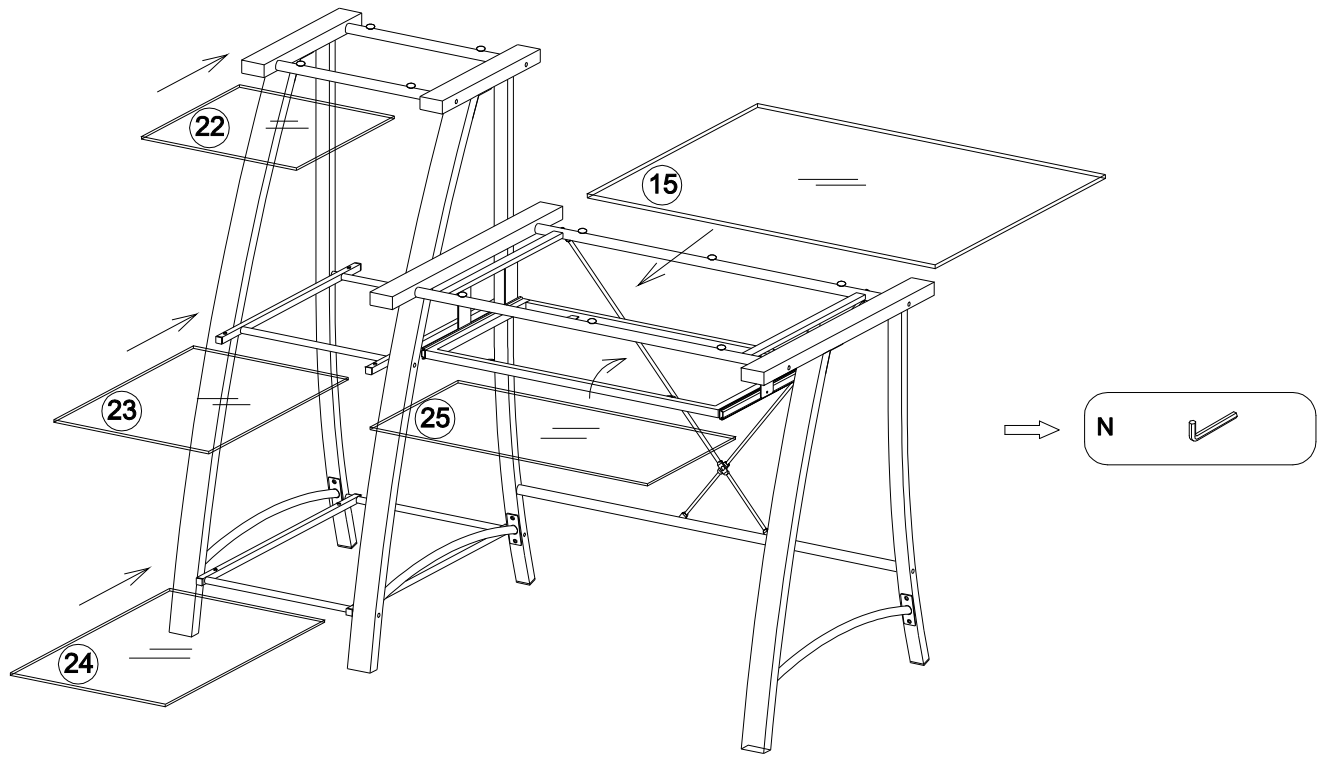

1. Carefully place (15) Desktop Glass down into position as shown, making sure that the glass rests evenly on all (J) Suction Cups (installed in Step 6).
2. Next, carefully place (25) Keyboard Glass into position as shown, making sure that it rests evenly on all (J) Suction Cups (installed in Step 6).
3. Lastly, carefully install (22) Left Upper Glass, (23) Left Middle Glass and (24) Left Lower Glass into their corresponding positions as shown. Make sure that each glass panel rests evenly on either (J) Suction Cups or (K) Adhesive Glass Supports (installed in Step 6).
4. **AT THIS TIME, FULLY TIGHTEN ALL ALLEN BOLTS FROM STEPS 1-6 USING (N) ALLEN WRENCH.**

**CONGRATULATIONS, YOUR Z-LINE DESIGNS TRIANA DESK & BOOKCASE IS NOW COMPLETE!**

Please see Page 13 for Dimensions & Maximum Weight Capacity information.

## DIMENSIONS

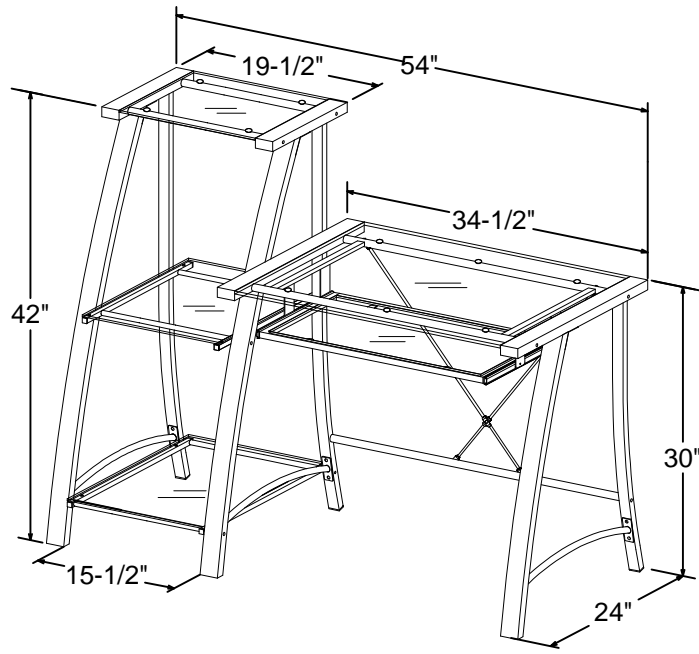

Product Size: 54" (W) x 24" (D) x 42" (H)

## MAXIMUM WEIGHT CAPACITIES



**⚠ WARNING: THIS PRODUCT IS INTENDED TO HOLD THE MAXIMUM WEIGHT (EVENLY DISTRIBUTED) INDICATED. EXCEEDING THE MAXIMUM WEIGHT WILL RESULT IN INSTABILITY AND MAY CAUSE POSSIBLE INJURY.**

**If the glass is chipped or broken stop using the product and consult the manufacturer or supplier.**

**\* GLASS WARNING:**

- **DO NOT** place very hot or very cold items on the glass surface(s) unless adequately thick table mats are used to prevent such items from coming into contact with the glass.
- **DO NOT** sit or stand on the glass surface(s).
- **DO NOT** use the glass as a chopping surface.
- **DO NOT** strike the glass with hard or pointed items.
- **When cleaning the glass, use a liquid glass surface cleanser and a soft cloth; DO NOT use harsh powders or any other abrasive substances as they will scratch the glass.**



Creating beauty, Manufacturing great value!



## 1 Year Limited Warranty

Thank you for purchasing a Z-Line Designs product. We promise to repair or replace any Z-Line Designs product or component that may have any defects in material or workmanship for as long as you, the original purchaser, own it. This warranty is subject to the provisions below. Z-Line Designs' sole obligation and purchasers' exclusive remedy pursuant to these warranties are limited to replacement at Z-Line Designs sole discretion. There are no other warranties except as expressly set forth below, either expressed or implied, including any warranty of merchantability for any particular purpose.

The word "defects" in this warranty is defined as imperfections that impair the service, function or effectiveness of the product.

### 1 YEAR:

Glides, casters and user-adjustable work surface mechanisms, laminates, veneer finishes and other materials which cover your Z-Line Designs product.

### INFORMATION ON COLOR VARIATIONS & FINISHES:

Some natural variations occurring in wood, or other natural materials are inherent to their character, and thus can not be avoided. Therefore they are not considered to be defects. Z-Line Designs does not warrant the color-fastness or matching of colors, grains, textures or other such materials. Customers' own materials selected by and used at the request of a user is therefore not warranted by Z-Line Designs.

### LIMITATIONS INVOLVING MATERIALS & COMPONENTS:

The materials and all components listed below are covered according to the following schedule from the date of sale to the original purchaser.

### EXCLUSIONS:

This warranty does not apply to: damage caused by the carrier, modifications to the product, or attachments to the product not approved by Z-Line Designs, non-standard materials selected by and used at the request of a user, and products that were not installed, used or maintained in accordance with product instructions and warnings. Nor shall Z-Line Designs have any responsibility for incidental or consequential damages resulting from the breach of this Warranty, including but not limited to inconvenience, rental or purchase of replacement products, loss of profits or commercial loss. Some states do not allow the exclusion or limitation of incidental or consequential damages so the above limitation or exclusion may not apply to you. This warranty gives you specific legal rights and you may also have other rights, which may vary from state to state. This warranty applies only to products sold within the United States of America and the Commonwealth of Canada.

### TO OBTAIN SERVICE FROM THIS WARRANTY:

Your Z-Line Designs' dealer is our mutual partner in supporting your warranty requests. By following the procedures instructed below, you are assured that you will receive the best level of customer service guaranteed.

- A) Please contact the local Dealer from whom you originally purchased within 30 days (**unless otherwise noted by the Dealer**) of discovery of the defect. Prepare to confirm that you are the original purchaser of the product and provide necessary product information, such as serial number(s)/ UPC number(s) from the product in question.
- B) The Dealer will gather all the pertinent information required regarding your claim(s), inspect the product and thus contact a Z-Line Designs Customer Service Representative. (Please allow a reasonable amount of time for inspection, review, and response to Dealer.
- C) If the Z-Line Designs Dealer confirms that the product in review is eligible under the warranty conditions as stated above, the customer service representative or another representative of the Company will determine whether to provide replacement parts, or authorize other arrangements at the sole discretion of the vendor, Z-Line Designs. No assembly/labor is included in this warranty.

### TO CONTACT CUSTOMER SERVICE:

Our knowledgeable Service Representatives are ready to assist you in the case this warranty applies to you. Please be prepared to explain the defect in detail, model/style number, date and location of purchase, your name, address, phone number and have your original sales receipt.

Please contact us Monday-Friday (except all major holidays) at:

Toll Free 1-888-736-2141 from 7:00 am – 3:30 pm (Pacific Standard Time) OR Email us: [customerservice@z-linedesigns.com](mailto:customerservice@z-linedesigns.com)

OR

Contact your local dealer from whom you originally purchased the product in question.



