

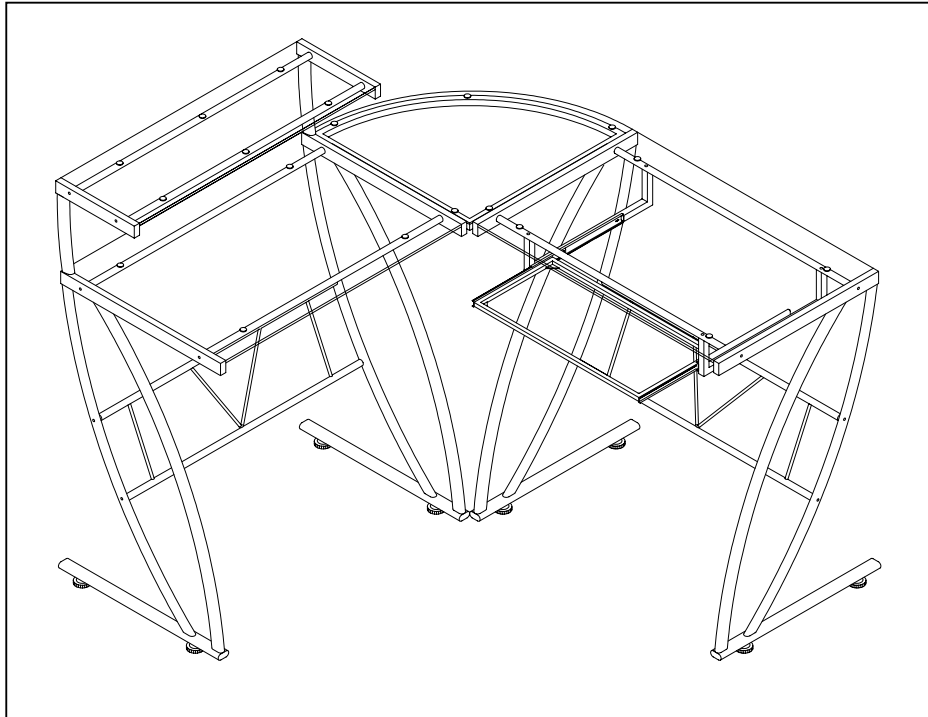

Belaire Glass L Desk

ZLN # ZL1441-1DU



⚠ DO NOT return to the store if parts are missing or damaged.

For Parts Replacements and Inquiries, please call us Toll-Free 1-888-736-2141 or E-mail

CustomerService@Z-LineDesigns.com.

To ensure a timely delivery, please include the following:

1. Full Name
2. Physical Address (Our primary carrier, FedEx, will NOT deliver to P.O. Boxes)
3. Phone Number
4. QC Number: SH _____
5. ZLN Number: ZL1441-1DU
6. Part Number(s) or Letter(s)
7. Quantity
8. We also request that you please provide a brief description of the reason for your request.

Our Customer Service Representatives will be available to assist you Monday – Friday 7:00 am to 3:30 pm Pacific Standard Time (Except Holidays).

022808

Important

Estimated Assembly Time: 1hr

⚠ TWO PEOPLE ARE NECESSARY FOR THE ASSEMBLY OF THIS PRODUCT.





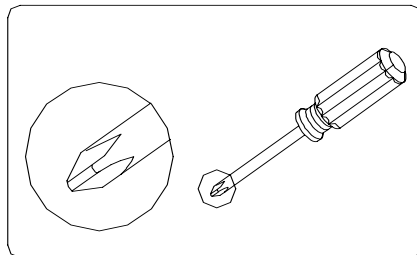



Before you begin: Open, identify, and count all parts prior to assembly. Lay out on non-abrasive surface. You will need the parts identified on page 3 - 5 of this instruction manual.

NECESSARY TOOLS – YOU WILL NEED PHILLIPS HEAD SCREW DRIVER FOR ASSEMBLY





NOW YOU ARE READY TO BEGIN ACTUAL ASSEMBLY!

HARDWARE IDENTIFICATION



A		FLOOR LEVELER (FL81530)	8 PCS
B		6x50x10mm ALLEN BOLT (AB65010BL)	4 PCS
C		6x32x10mm ALLEN BOLT (AB63210BL)	16 PCS
D		6x32x10mm FLAT HEAD ALLEN BOLT (ABFH63210BL)	4 PCS
E		ALLEN WRENCH (AW4BL)	1 PC
F		4x12x8mm WOOD SCREW (RHWS4128BL)	4 PCS
G		RUBBER PLUG	19 PCS
H		FELT PAD	4 PCS

*Extra hardware is enclosed for your convenience.

THE BELOW PARTS ARE PRE-ASSEMBLED AND ARE LISTED AS A REFERENCE ONLY.

I		UPPER PLASTIC END CAP	10 PCS
J		LOWER PLASTIC END CAP	8 PCS

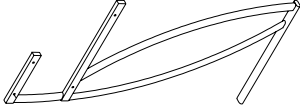
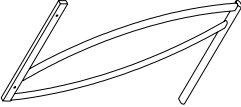
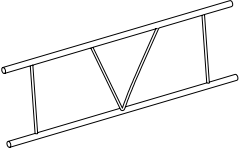
PARTS IDENTIFICATION-1

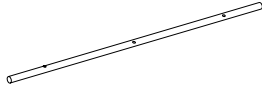
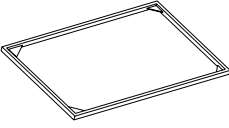
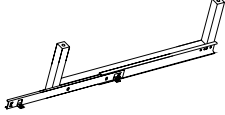
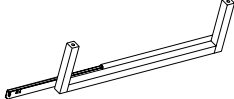
①		MAIN DESK FRAME	2 PCS
②		COMPUTER DESK FRAME	2 PCS
③		BACK FRAME	2 PCS
④		COMPUTER DESK CROSSBAR	2 PCS
⑤		MAIN DESK CROSSBAR	2 PCS
⑥		SHELF CROSSBAR	2 PCS
⑦		KEYBOARD FRAME	1 PC
⑧		LEFT KEYBOARD GLIDE	1 PC
⑨		RIGHT KEYBOARD GLIDE	1 PC

PARTS IDENTIFICATION-2

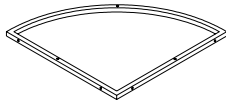
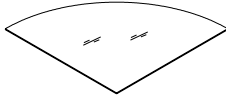
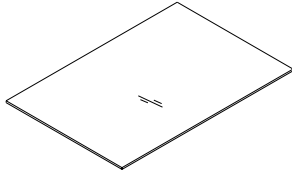
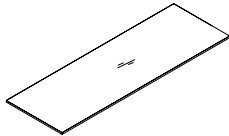
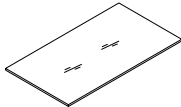
10		CORNER FRAME	1 PC
11		CORNER GLASS	1 PC
12		DESK GLASS	2 PCS
13		SHELF GLASS	1 PC
14		KEYBOARD GLASS	1 PC

ASSEMBLY INSTRUCTION

STEP 1

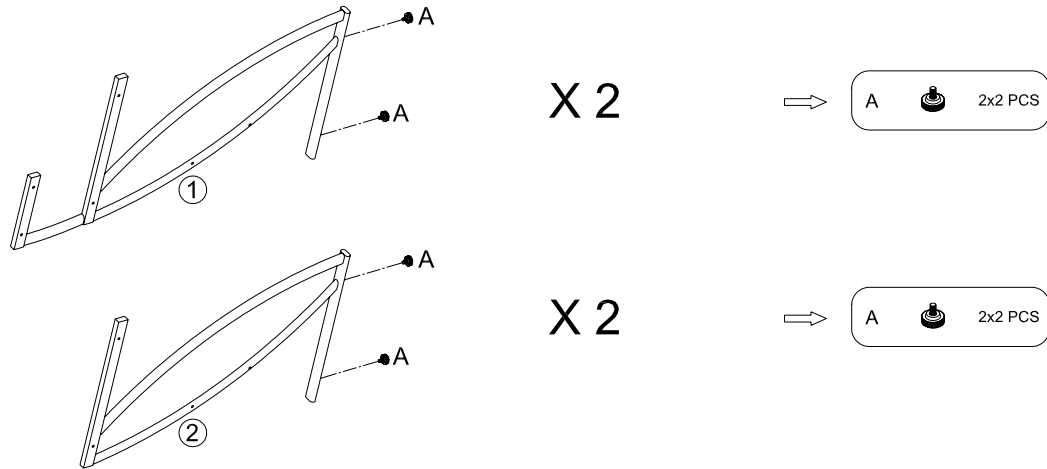

Insert (A) Floor Levelers into the BOTTOMS of (1) Main Desk Frames and (2) Computer Desk Frames as shown.

STEP 2

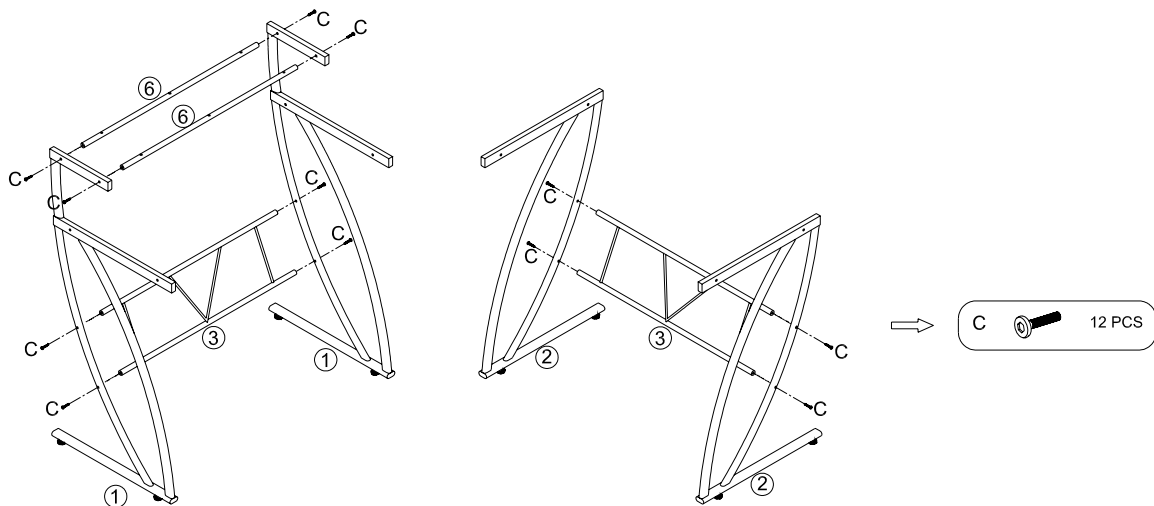

DO NOT FULLY TIGHTEN ALLEN BOLTS UNTIL THE END OF STEP 7.

1. Connect (3) Back Frame and (6) Shelf Crossbars to (1) Main Desk Frames with (C) 6 x 32 x 10mm Allen Bolts.

***NOTE: Make sure the holes located on (6) Shelf Crossbars that connect to (G) Rubber Plugs (in Step 5) face UPWARD.**

2. Now connect (3) Back Frame to (2) Computer Desk Frames with (C) 6 x 32 x 10mm Allen Bolts.

***NOTE: THE MAIN DESK AND COMPUTER DESK CAN BE REVERSED TO YOUR PREFERENCE. PLEASE DECIDE AT THIS TIME WHICH SIDE YOU WANT THE MAIN DESK BEFORE CONTINUING ON WITH THE NEXT STEP.**

STEP 3

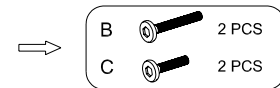
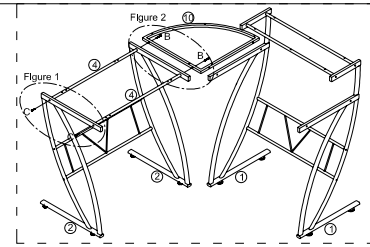
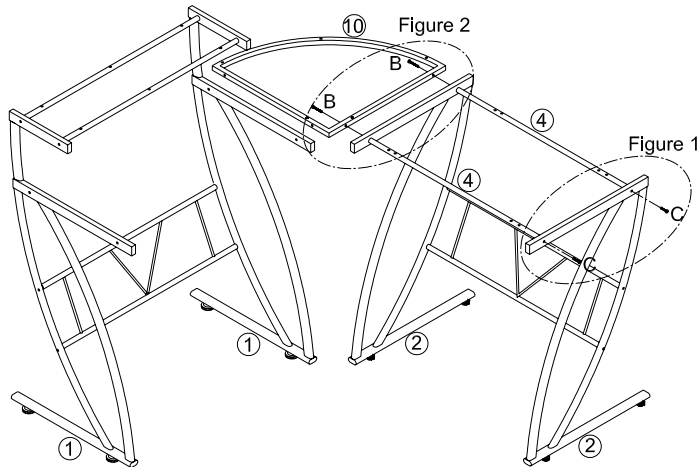

DO NOT FULLY TIGHTEN ALLEN BOLTS UNTIL THE END OF STEP 7.

1. Set the Main Desk and Computer Desk in the desired positions as shown in either of the illustrations above.
2. Connect (4) Computer Desk Crossbars to the OUTSIDE of the Computer Desk with (C) 6 x 32 x 10mm Allen Bolts as shown in Figure 1.
3. Now connect (10) Corner Frame through the INSIDE of the Computer Desk to (4) Computer Desk Crossbars with (B) 6 x 50 x 10mm Allen Bolts as shown in Figure 2.

***NOTE: Make sure the holes located on (4) Computer Desk Crossbars and (10) Corner Frame that connect to (G) Rubber Plugs (in Step 5) face UPWARD.**

***NOTE: You will need a second person to hold the other end of (10) Corner Frame in place until the next step.**

STEP 4

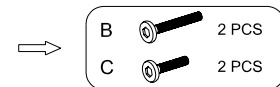
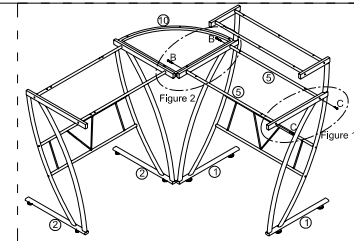
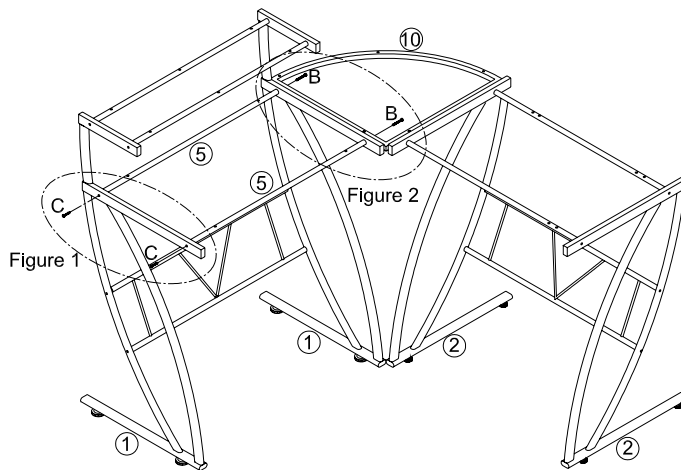

DO NOT FULLY TIGHTEN ALLEN BOLTS UNTIL THE END OF STEP 7.

1. Connect (5) Main Desk Crossbars to the OUTSIDE of the Main Desk with (C) 6 x 32 x 10mm Allen Bolts as shown in Figure 1.

***NOTE: Make sure the holes located on (5) Main Desk Crossbars that connect to (G) Rubber Plugs (in Step 5) face UPWARD.**

3. Now connect the remaining end of (10) Corner Frame through the INSIDE of the Main Desk to (5) Main Desk Crossbars with (B) 6 x 50 x 10mm Allen Bolts as shown in Figure 2.

STEP 5

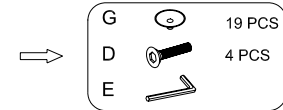
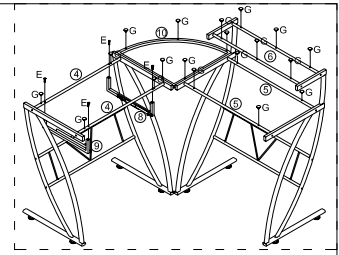
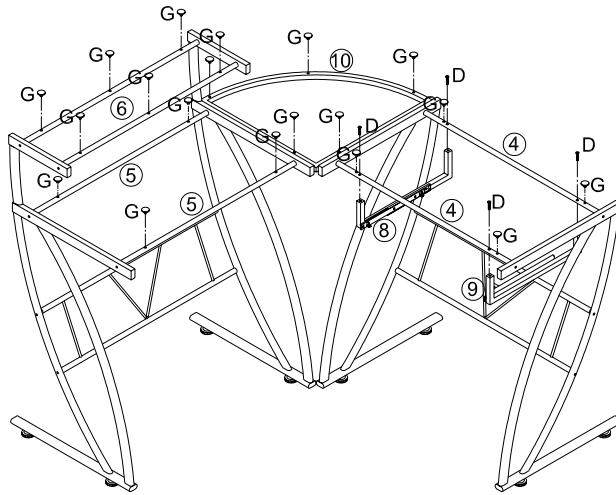

1. Connect (8) Left Keyboard Glide and (9) Right Keyboard Glide to (4) Computer Desk Crossbars, making sure the Glides extend toward the FRONT, with (D) 6 x 32 x 10mm Flat Head Allen Bolts. **FULLY TIGHTEN.**
2. Insert (G) Rubber Plugs into (4) Computer Desk Crossbars, (5) Main Desk Crossbars, (6) Shelf Crossbars, and (10) Corner Frame as shown.

STEP 6

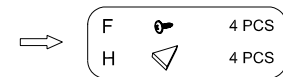
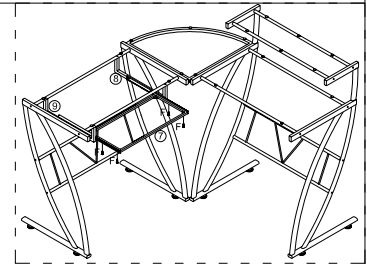
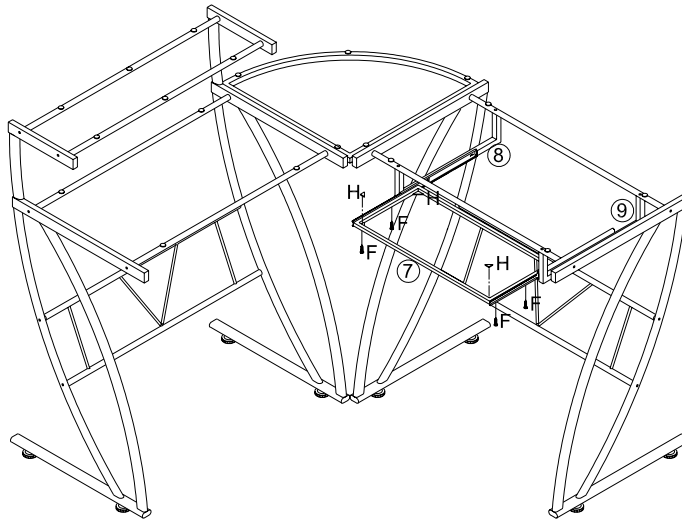

1. Extend the Keyboard Glides and set (7) Keyboard Frame in place as shown. Secure from UNDERNEATH with (F) 4 x 12 x 8mm Wood Screws.
2. Now adhere (H) Felt Pads to the Inside Corners of (7) Keyboard Frame.

STEP 7

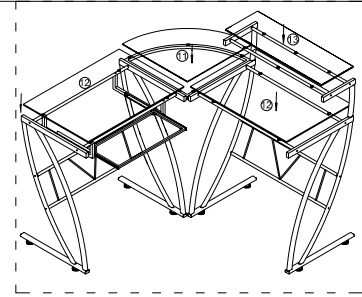
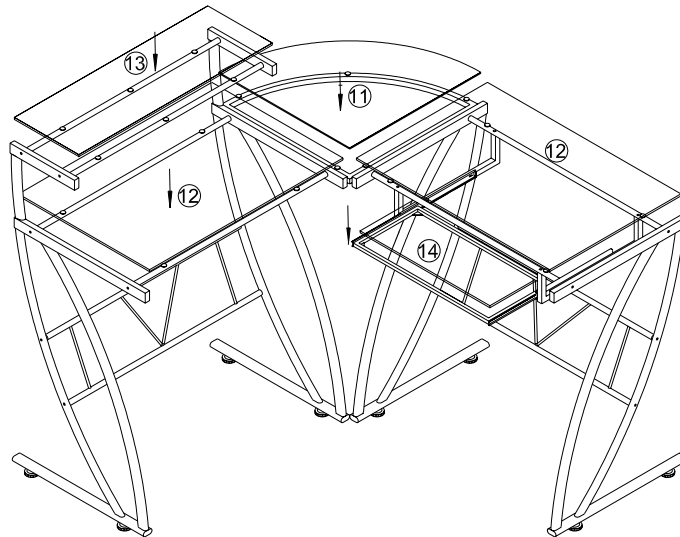

1. Carefully set (11) Corner Glass, (12) Desk Glass, (13) Shelf Glass, and (14) Keyboard Glass in place as shown.
2. Once the glass is in place, line up the unit to make sure it is square and the glass fits properly.
3. **FULLY TIGHTEN ALL ALLEN BOLTS AT THIS TIME** with (E) Allen Wrench.

***NOTE: You may need to go back through the steps to make sure you have tightened them all.**

CONGRATULATIONS, YOUR BELAIRE GLASS L DESK IS NOW COMPLETE!

DIMENSIONS

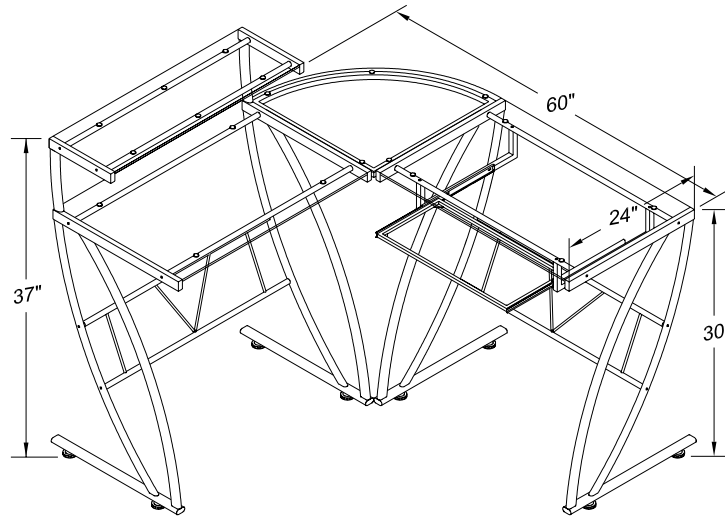

Product Size: 60"(W)x60"(D)x37"(H)

MAXIMUM WEIGHT CAPACITIES

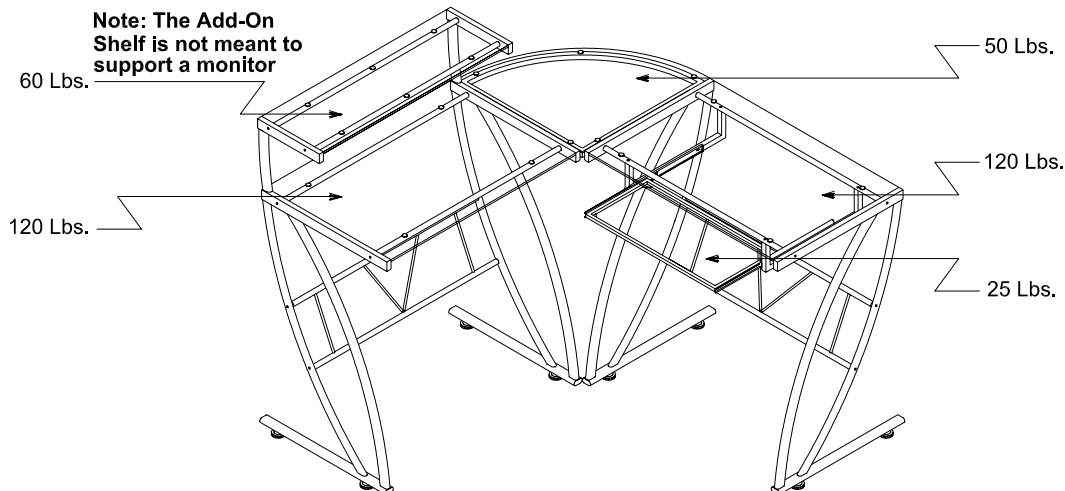

⚠ CAUTION: This product is intended to hold the Maximum Weight (**EVENLY DISTRIBUTED**) indicated. Exceeding the Maximum Weight will result in instability and may cause possible injury.

If the glass is chipped or broken stop using the product and consult the manufacturer or supplier.

* GLASS CAUTION:

- DO NOT place very hot or very cold items on the glass surface(s) unless adequately thick table mats are used to prevent such items from coming into contact with the glass.
- DO NOT sit or stand on the glass surface(s).
- DO NOT use the glass as a chopping surface.
- DO NOT strike the glass with hard or pointed items.
- When cleaning the glass, use a liquid glass surface cleanser and a soft cloth; DO NOT use harsh powders or any other abrasive substances as they will scratch the glass.