



Model 19250 "Swinger" Ladders

ASSEMBLY INSTRUCTIONS

1. Check parts against parts list.
2. Read Instructions completely before starting assembly.

Tools Required

1. Adjustable wrench to 1/2"
2. Screwdriver
3. Drill and Bits
4. Ruler

Refer to Fig. 1

1. Locate the area on your pontoon boat where the ladder is to be mounted. It is recommended that the ladder be placed near the side gate opening, such that when it is opened, the ladder will be deployed in the gate opening. Check the skirt edge where the ladder's mounting hardware will be placed. Make sure that the skirt edge will support the load of a person. If necessary, add fasteners to the extrusion at the indicated areas to reinforce the ladder mounting points.

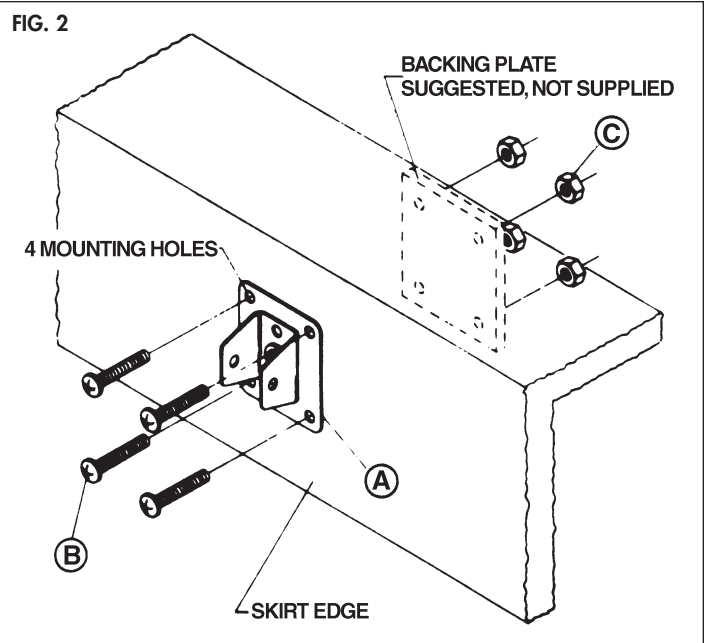
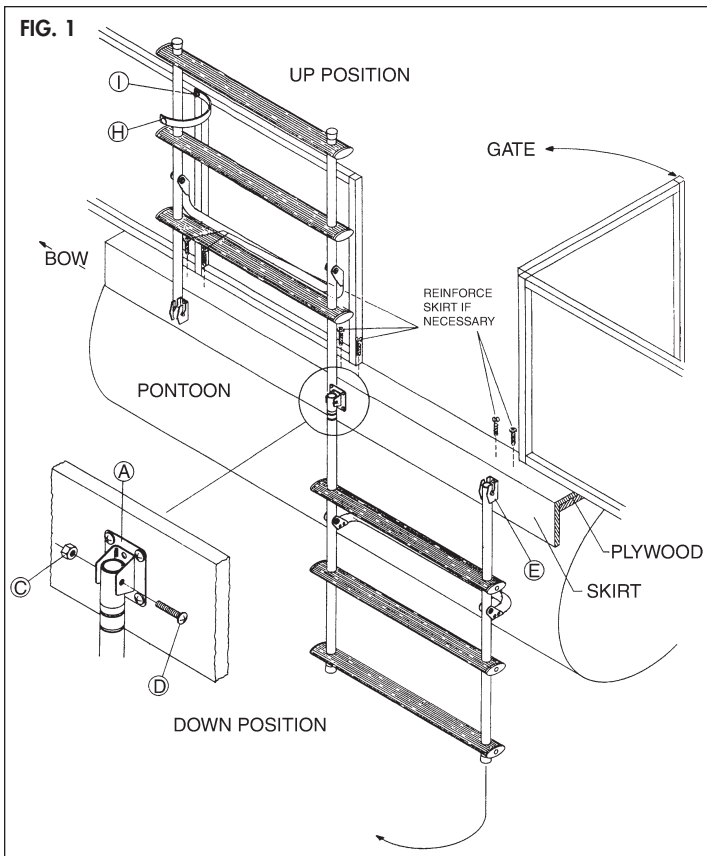

Refer to Fig. 2

2. Position the pivot bracket (A) on the skirt edge where the ladder is to be mounted. Mark and drill the four holes as shown. NOTE: It is recommended to use a backing plate for each piece of hardware that is attached to the skirt edge extrusion (see illustration).
3. Secure the pivot bracket (A) to your boat with screws (B) and locknuts (C).

Refer to Fig. 1

4. Attach the ladder to the mounted pivot bracket as shown by aligning the holes and inserting a 1/4-20 x 1 3/4" s.s. machine screw (D). Secure it in place with locknut (C).
5. Swing the ladder over to one side as shown and slide one of the mounting brackets (E) onto the ladder's rollpin as illustrated. Center the ladder in the bracket and make sure the rollpin is "bottomed out" in the bracket.
6. Position the bracket on the skirt edge with the ladder attached. Make sure the ladder is square and level with respect to the pivot bracket and boat. Mark and drill the holes in the skirt edge. NOTE: It is recommended to use a backing plate when installing this bracket (See Fig. 3).
7. Secure this bracket in place with screws (B) and locknuts (C).
8. Swing the ladder over to the remaining side as shown and repeat steps 1-3 for the remaining mounting bracket.

(over)

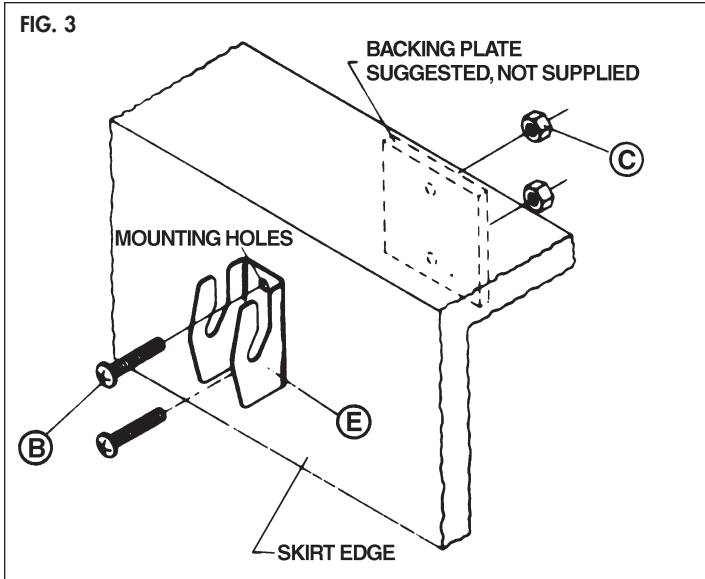

Refer to Fig. 4

9. Mount the standoff bar (F) to the ladder by locating a point where it abuts the pontoon log below its major diameter. This will force the standoff to remain in the open position when the ladder is in use. Check to make sure there is enough clearance to fold the standoff bar flat to the ladder verticals for stowage without contacting a step.

NOTE: If you are unable to position the standoff below the centerline of the pontoon and you must position the standoff above the centerline, then reverse the standoff so it folds down instead of up. This will force the standoff to remain in the open position when the ladder is in use.

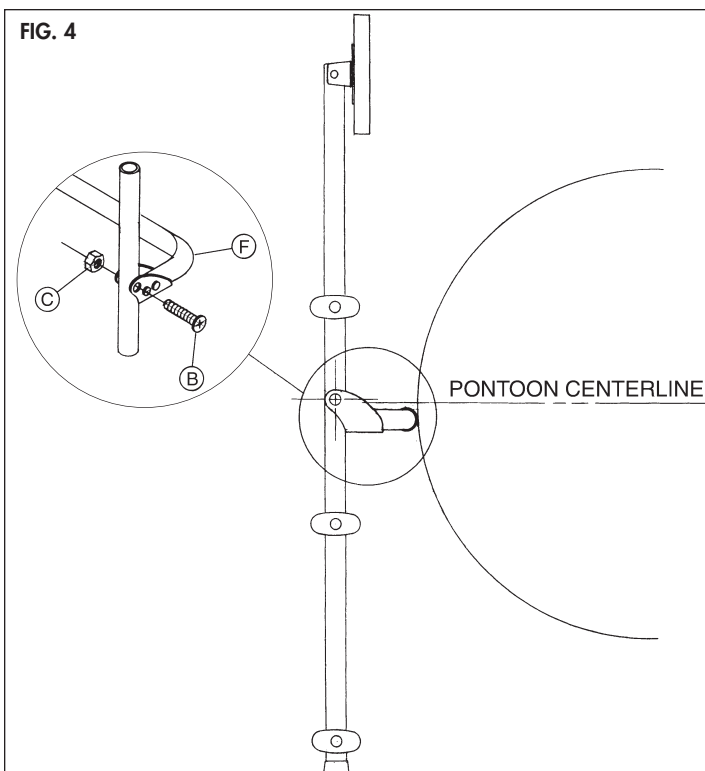

Parts List “Swinger” Ladder

Ref. Letter	Factory Part No.	No. Req.	Description
A	50.579	1	Pivot bracket
B	03.079	10	¼-20 x 1½" s.s. machine screw
C	03.221	11	¼-20 s.s. locknut
D	03.082	1	¼-20 x 1¾" s.s. machine screw
E	50.576	2	Mounting bracket
F	50.844	1	Standoff Bar
H	45.205	1	Velcro Strap

10. Drill a crosshole through the ladder with a 17/64" diameter bit at the point where the standoff's pivot hole contacts the ladder vertical. Secure the standoff in place with a screw (B) and locknut (C).

Refer to Fig. 1

12. Place the ladder in the "UP" and "STORED" position.
13. Locate the securing strap (H) in a place where it will be easy to attach and remove.
IF TRAILERING YOUR BOAT, MAKE SURE THE LADDER IS TIED SECURELY IN PLACE WITH AN ADDITIONAL LINE OR STRAP FOR ADDED SAFETY.

OPERATING INSTRUCTIONS

Refer to Fig. 1

TO OPEN

Release securing strap. Lower the standoffs. Lift the outside ladder vertical enough to clear the mounting bracket. Swing the ladder over to the other mounting bracket. Guide the ladder's rollpin into the bracket's grooves. Gently let the ladder flip over and fall into the water. The ladder is ready for boarding.

TO STOW

Lift the ladder up out of the water. Lift the outside ladder vertical enough to clear the mounting bracket. Swing the ladder over to the other mounting bracket. Guide the ladder's rollpin into the bracket's grooves. Secure the ladder in place with the securing strap.