

# ASSEMBLE INSTRUCTION

ITEM#: 3206-04

DESCRIPTION: END TABLE

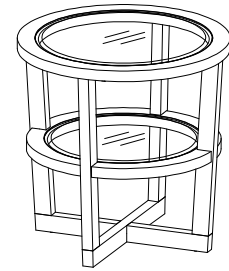

NO	HARDWARE LIST		QTY
A		Allen Wrench (5 mm)	1
B		Bolt (Φ5/16" x 2")	4
C		Bolt (Φ5/16" x 3/4")	8
D		Bolt (Φ5/16" x 3/4")	4
E		Lock Washer (Φ5/16")	12
F		Washer (Φ5/16")	12
G		Plate Metal	4
H		Upper Glass	1
I		Lower Glass	1

NO	PARST LIST		QTY
a		Upper Top	1
b		Lower Top	1
c		LEG	4
d		Upper Leg	1
e		Lower Leg	1

STEP: 1

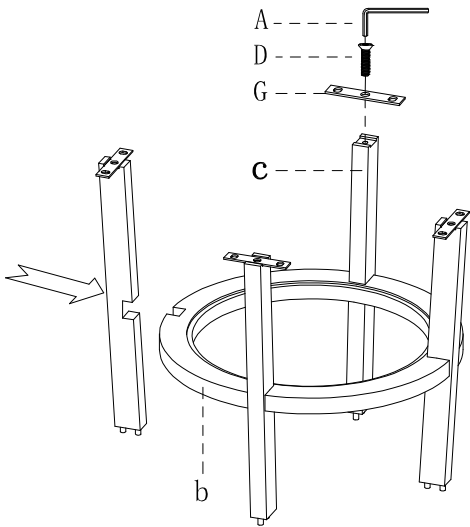

STEP: 2

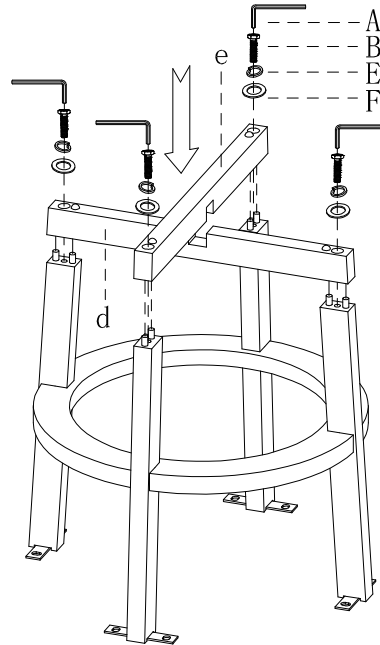

**STEP: 3**

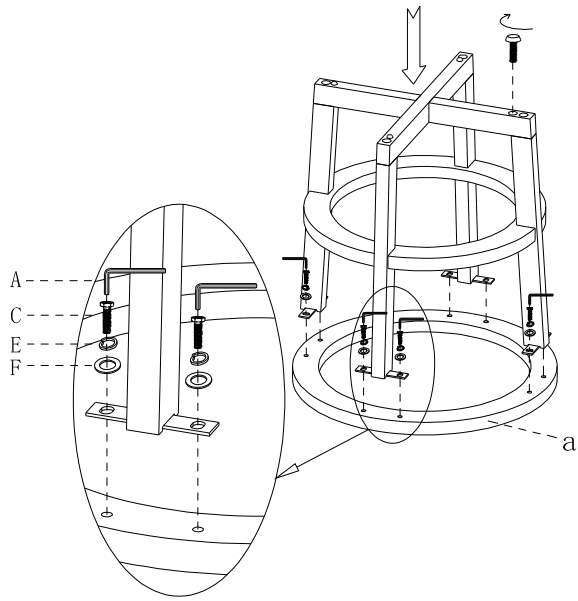

**STEP: 4**

