

INSTALLATION INSTRUCTIONS

USA

V/A

V/A ADAPTOR

ART. NO.	160 050bz	bronze
	160 050ch	chrome
	160 050ch	gold and black
	160 050mcgy	matte chrome

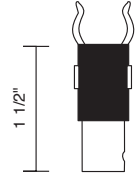

IMPORTANT SAFETY INSTRUCTIONS



1. Read all of these installation Instructions before installing the track system.
2. Save these instructions and refer to them when additions to or changes in the track configuration are made.
3. THIS PRODUCT MUST BE INSTALLED BY A PERSON FAMILIAR WITH THE CONSTRUCTION AND OPERATION OF THE PRODUCT AND THE HAZARDS INVOLVED, IN ACCORDANCE WITH LOCAL NEC CODE.
4. FOR USE WITH V/A NETWORK ONLY.
5. Do not install the track or any part which contains exposed wires less than 7 feet from the floor.
6. Do not install this rail in damp or wet locations.
7. Do not install fixture assembly closer than 6 inches from any curtain, or similar combustible material.
8. Disconnect electrical power before adding to or changing the configuration of the track.
9. Do not attempt to energize anything other than lighting rail fixtures on the rail. To reduce the risk of fire and electrical shock, do not attempt to connect power tools, extension cords, appliances, and the like to the rail.
10. This track system MUST BE HARD WIRED. For all the wire connections, use Listed Wire Nuts.
11. Secondary connections must be clean and tight to avoid arcing and overheating!
12. Warranty is void in case of unauthorized modifications and/ or improper use.

READ ALL OF THESE INSTALLATION INSTRUCTIONS BEFORE INSTALLING THE SYSTEM

Fig 1. The V/A adaptor clamps directly onto the V/A track. Tilt the adaptor at an angle when attaching it to the track.

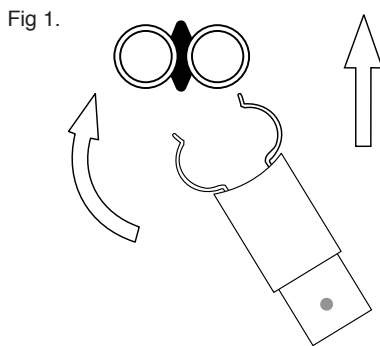

Fig 2.

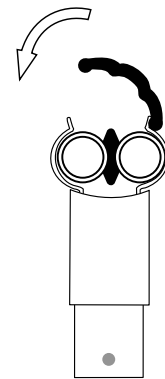
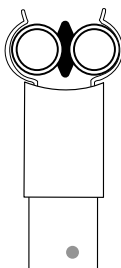

Fig 2. The retaining clip fits over the top of the track to prevent accidental disconnection from the track. The plastic retaining clip hooks onto the two ends of the metal adaptor clip.

Klick!



Klick!

