

ASSEMBLY INSTRUCTION
COASTER FINE FURNITURE



ASSEMBLY INSTRUCTION

ASSEMBLY TIPS:









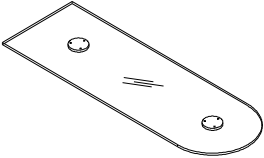
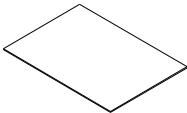

- 1.Remove hardware from box and sort by size.
- 2.Please check to see that all hardware and parts are present prior to start of assembly.
- 3.Please follow attached instructions in the same sequence as numbered to assure fast & easy assembly.

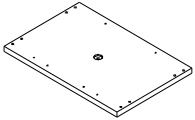

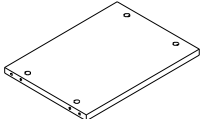
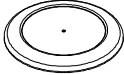

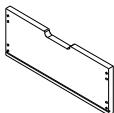

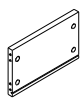





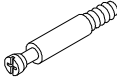

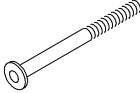

Warning!!

- 1.Don't attempt to repair or modify parts that are broken or defective.Please contact the store immediately.
- 2.This product is for home use only and not intended for commercial establishment.

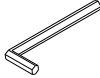
PARTS IDENTIFICATION

(A) TOP GLASS		1PC	(H) DRAWER BOTTOM PANEL		1PC
(B) SIDE BOARD		2PCS	(I) TOP GLASS SUPPORT BAR		1PC
(C) TOP BOARD		1PC	(J) CENTER SUPPORT WOOD		1PC
(D) BASE AND MIDDLE SHELF		3PCS	(K) CENTER SUPPORT METAL		1PC
(E) BOTTLE RACK		2PCS	(L) CENTER SWIVEL PART		1PC
(F) DRAWER FRONT PANEL		2PCS	(M) TOP GLASS SUPPORT LEG		1PC
(G) DRAWER SIDE PANEL		2PCS	(N) GLASS HOLDER		2PCS

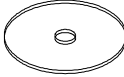
HARDWARE PACKAGE

Z	DESCRIPTION	FIGURE	Q'TY
1	CAM-BOLT		20pcs
2	LARGE CAM-LOCK		16pcs
3	LARGE ALLEN BOLT		2pcs
4	PLASTIC WASHER		1pc
5	SMALL CAM-LOCK		8pcs
6	SMALL WASHER		2pcs
7	SPRING WASHER		2pcs
8	WOOD DOWEL		20pcs
9	LARGE ALLEN KEY		1pc
10	SCREW		14pcs
11	FLOOR PROTECTOR		4pcs
12	GLUE		1pc
13	SMALL ALLEN BOLT		6pcs
14	LARGE WASHER		2pcs
15	LABEL		4pcs
16	SMALL ALLEN KEY		1pc

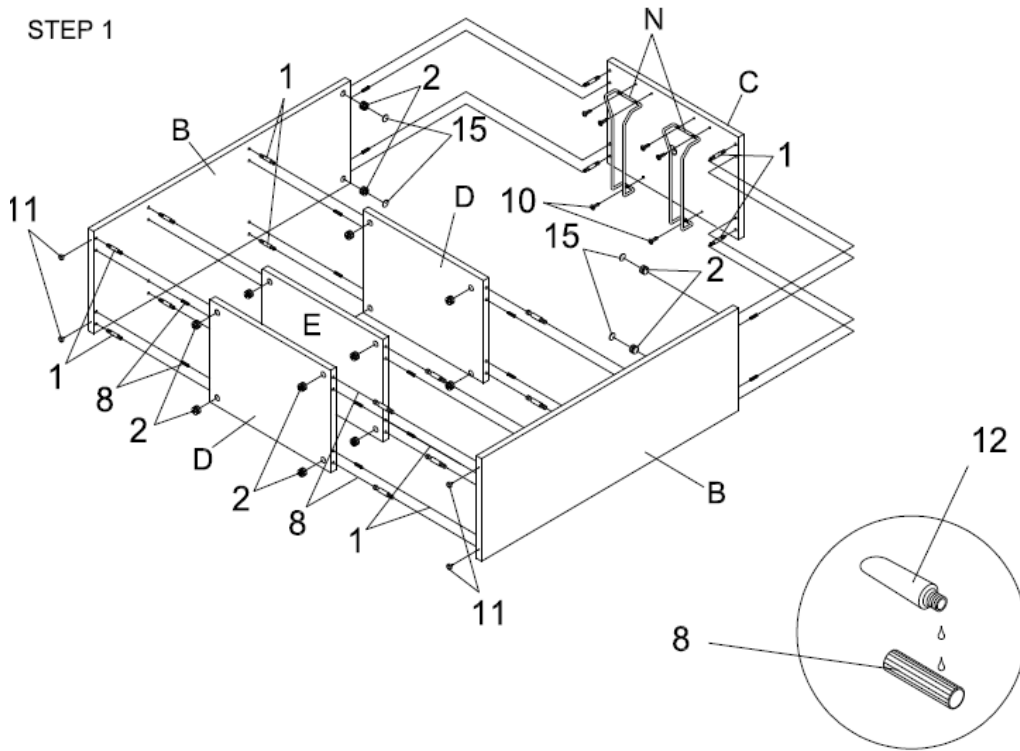

STEP1:

1. Use SCREW(10) to connect GLASS HOLDER(N) with TOP BOARD(C), screw CAM-BOLT(1) onto TOP BOARD(C) and SIDE BOARD(B).
2. Install WOOD DOWEL(8) onto SIDE BOARD(B) and screw LARGE CAM-LOCK(2) onto SIDE BOARD(B).
3. Install screw LARGE CAM-LOCK(2) onto BASE AND MIDDLE SHELF(D).
4. Assemble BASE AND MIDDLE SHELF(D) with SIDE BOARD(B), Tighten all screws.
5. Assemble TOP BOARD(C) with SIDE BOARD(B), Tighten all screws.
6. Nail FLOOR PROTECTOR(11) onto SIDE BOARD(B) Set the finished product standing up.

STEP2:

1. Add SPRING WASHER(7) and SMALL WASHER(6) onto LARGE ALLEN BOLT(3), then insert CENTER SWIVEL PART(L) and CENTER SUPPORT METAL(K) and CENTER SUPPORT WOOD(J) and LARGE WASHER(14) onto LARGE ALLEN BOLT(3). Then screw TOP GLASS SUPPORT BAR(I) onto LARGE ALLEN BOLT(3).

STEP 2

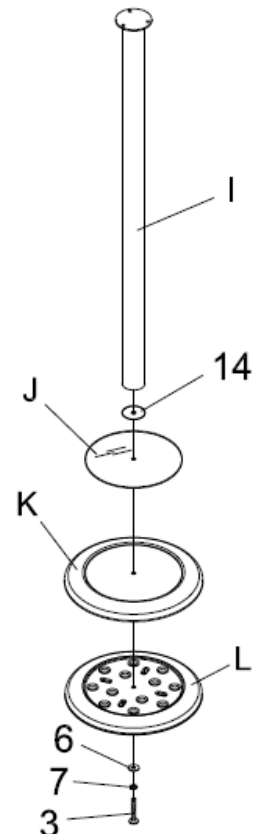

STEP 3

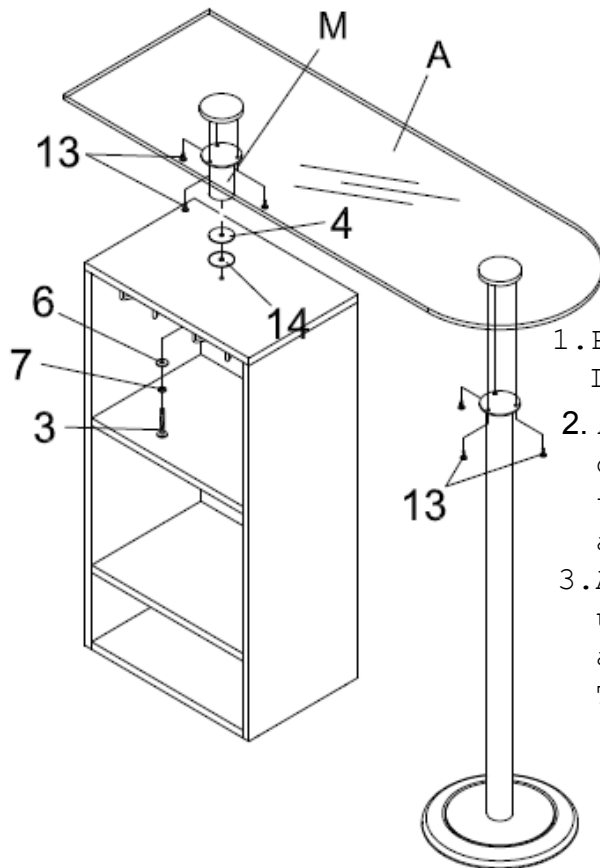

STEP3:

1. Place and PLASTIC WASHER (4) and LARGE WASHER (14) hole of TOP BOARD (C).
2. Add SMALL WASHER (6) and SPRING WASHER (7) onto LARGE ALLEN BOLT (3), then screw it together with TOP GLASS SUPPORT BAR (M) and onto TOP BOARD (C).
3. Assemble TOP GLASS SUPPORT BAR (I) using TOP GLASS SUPPORT LEG (M) and SMALL ALLEN BOLT (13) with TOP GLASS (A).

STEP 4

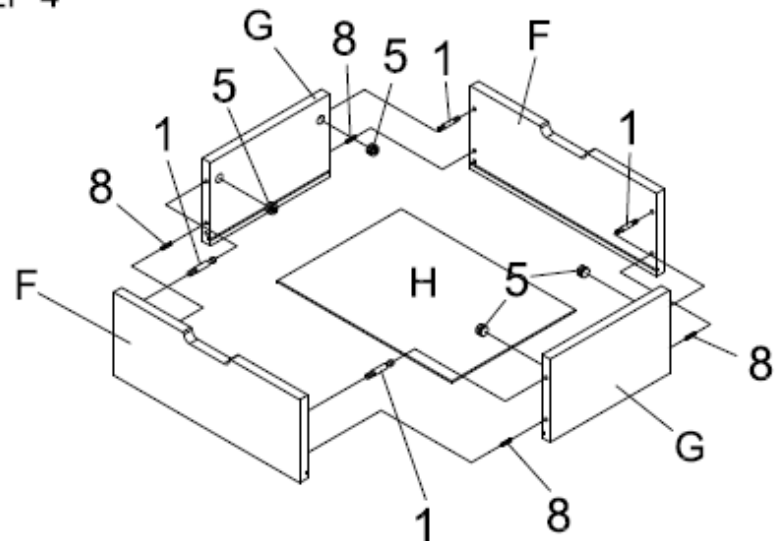

STEP4:

1. Screw CAM-BOLT (1) onto DRAWER FRONT PANEL (F), Screw and install SMALL CAM-LOCK (5) and WOOD DOWEL (8) onto DRAWER SIDE PANEL (G).
2. Insert DRAWER BOTTOM PANEL (H) with DRAWER FRONT PANEL (F) and connect DRAWER SIDE PANEL (G), then tighten all screws.
3. Insert DRAWER FRONT PANEL (F) with DRAWER BOTTOM PANEL (H), then tighten all screws

STEP 5

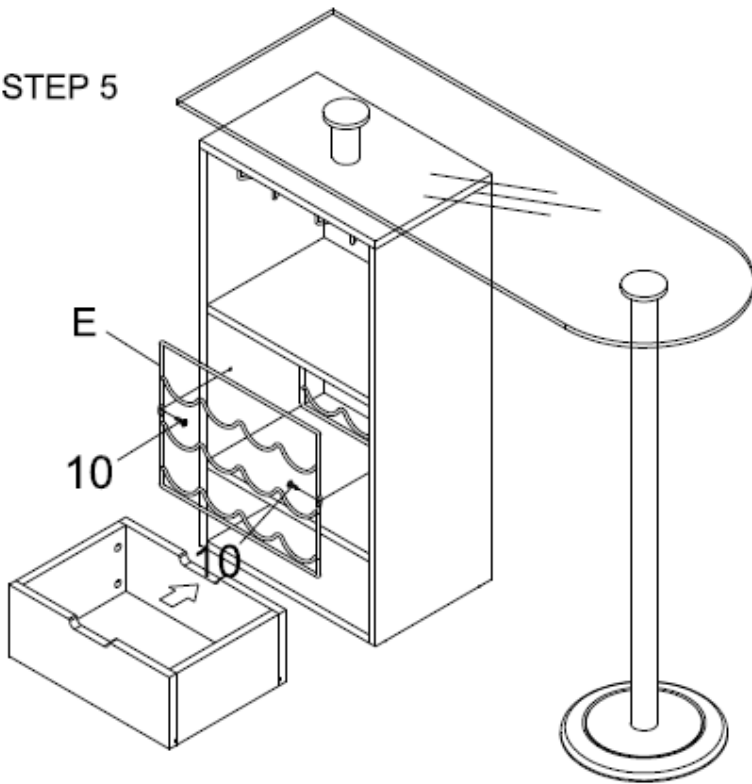

STEP5:

1. Install BOTTLE RACK (E) onto SIDE BOARD (B) using SCREW (10).
Insert the completed drawer into the bottom.

FINISH

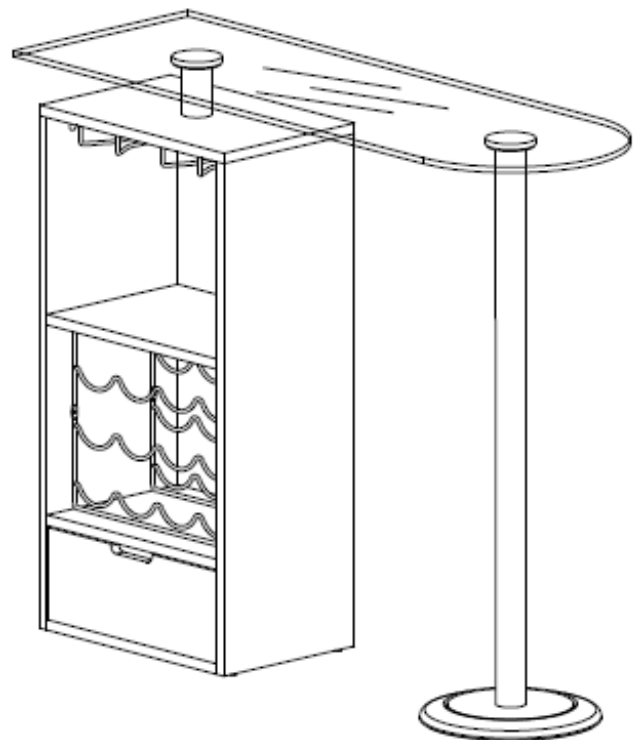
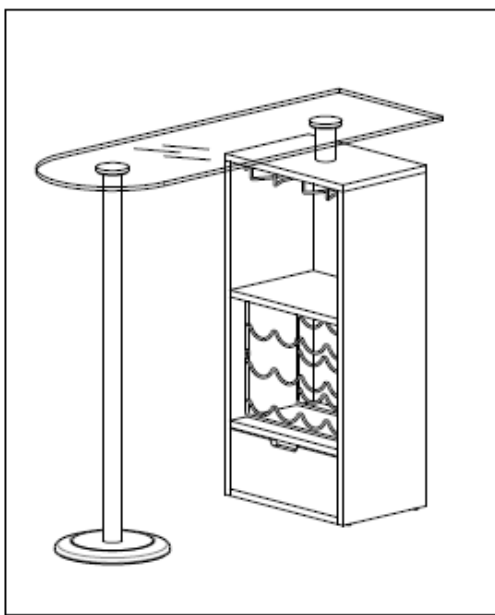

this can be placed either way to suit the individual's needs