

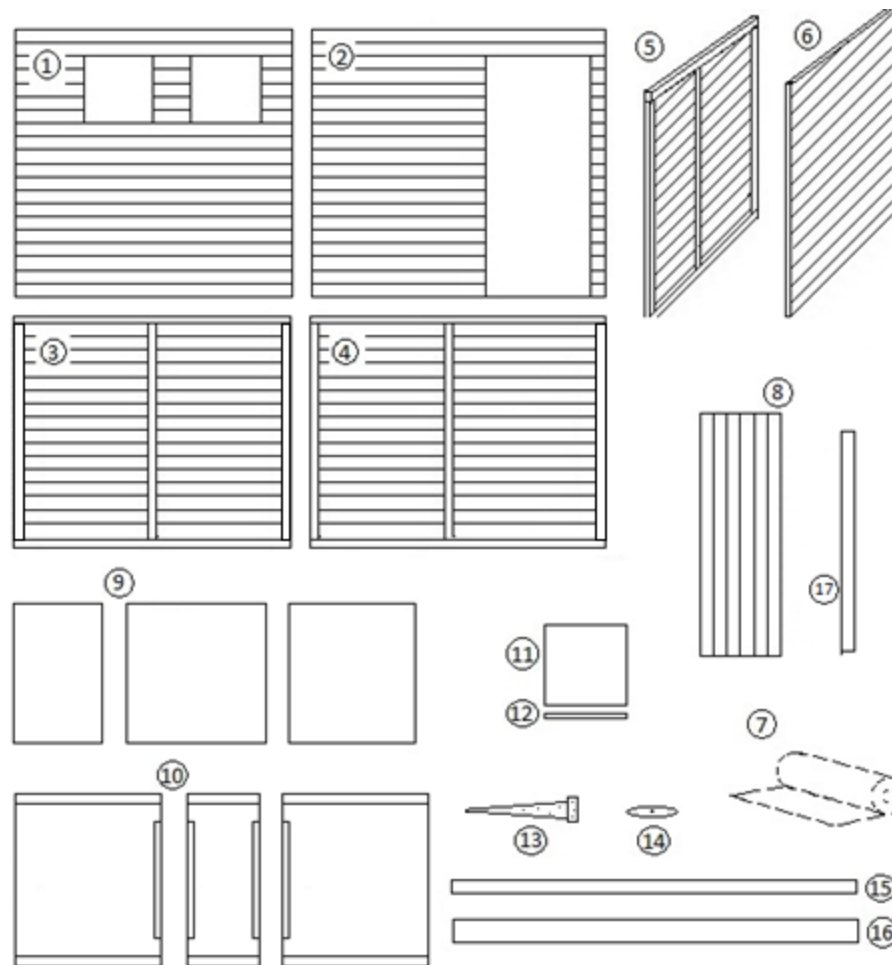

The type and quantity of components may vary for different style sheds.  
Assembly of all shed styles is by the same method as detailed.

Before assembling the shed, please check that all parts are present. Report any shortages or other issues immediately.

**DO NOT** attempt to modify the shed or any of it's parts as this may invalidate the warranty.



No.	Componets	Number
1	Front left panel	1
2	Front right panel	1
3	Rear right panel	1
4	Left rear panel	1
5	Left side panel	1 (8ft side = 2 x 4ft panel)
6	Right side panel	1 (8ft side = 2 x 4ft panel)
7	Felt	1
8	Door	1 (single door) 2 (double door)
9	Floor (may be 2, 3 or 4panels)	2, 3 or 4 (depending shed size)
10	Roof panel ( may be 2, 3 or 4panels)	2, 3 or 4 (depending shed size)
11	Windows (optional)	Optional
12	Window bead 15mm x 20mm (optional)	Optional
13	Tee Hinges	3 (single door) 6 (double door)
14	Turn button	1 (single door) 2 (double door)
15	Floor bearers tanalised 26mm x 38mm	Variable
16	Barge boards	Variable
17	Corner cover strips 11mm x 41mm	4
17	Joining strips 11mm x 41mm	2 (8ft sides = 4)

No.	Fixings	
1	60mm screws	
2	40mm screws	
3	25mm black screws	
4	30mm nails	
5	10mm clout nails	
6	30mm panel pins (windows options only)	

## 1. Floor Section

The floor and floor bearers are supplied separately. The ROOF is supplied with batons attached.

If your shed has two or more floor boards, please follow one of the following methods shown in the diagram below.

The floor bearers will be either the same length as the width or the depth of the floor.

Place each floor bearer approx. 30cms apart ensuring that one bearer is fixed along both outer edges of the floor.

Fix the floor bearers to the floor using the 30 nails. Lay the floor board on top of bearers and nail through the floor into the bearers.

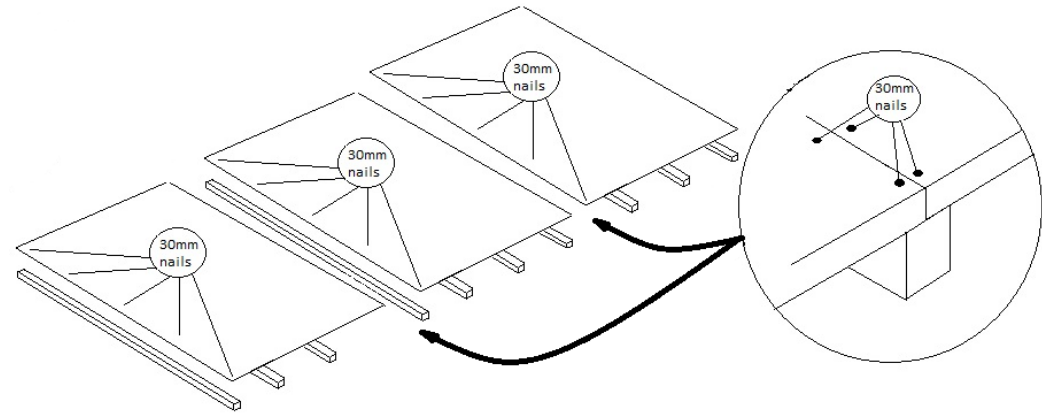
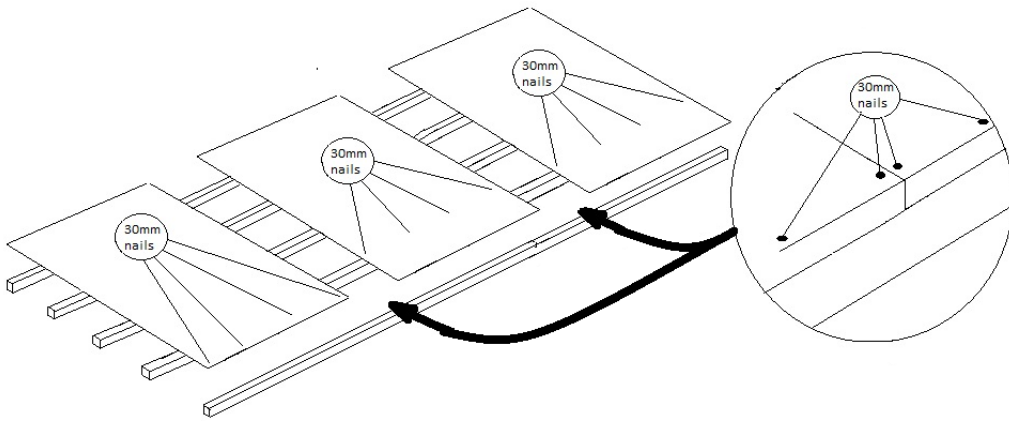

## 2. Wall Panels

### Step 1

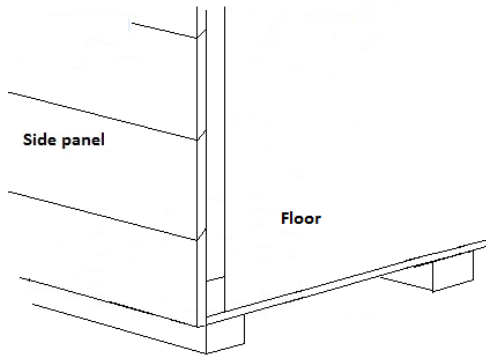

**Step 1.** Position the first side panel so that the edge of the panel is flush with the edge of the floor and the overhang on the bottom of the panel is butted up to the floor.

### Step 2

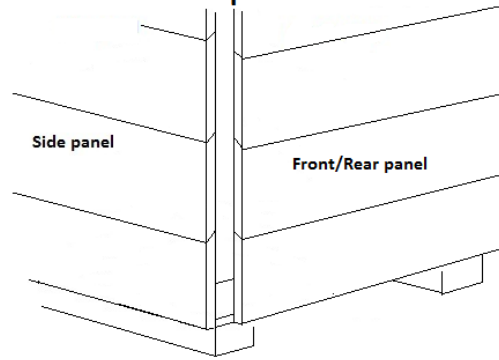

**Step 2.** Then place the front or rear panel along the edge of the floor and line up the framework of both of the panels to make a corner.

### Step 3.

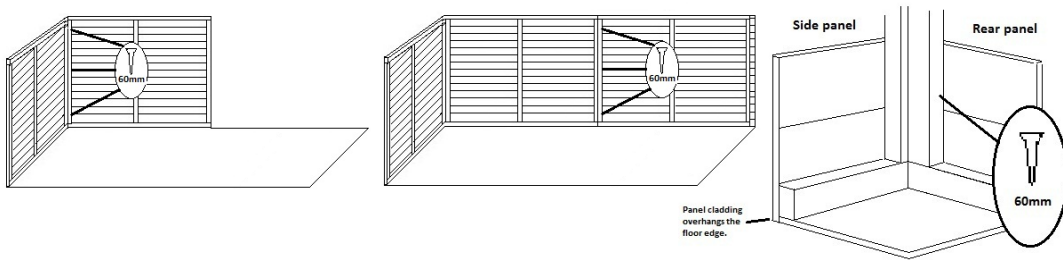

### Step 4.



When all sides of the shed are upright and screwed together, use the 60mm screws to secure the side to the floor as shown above.

### Step.5

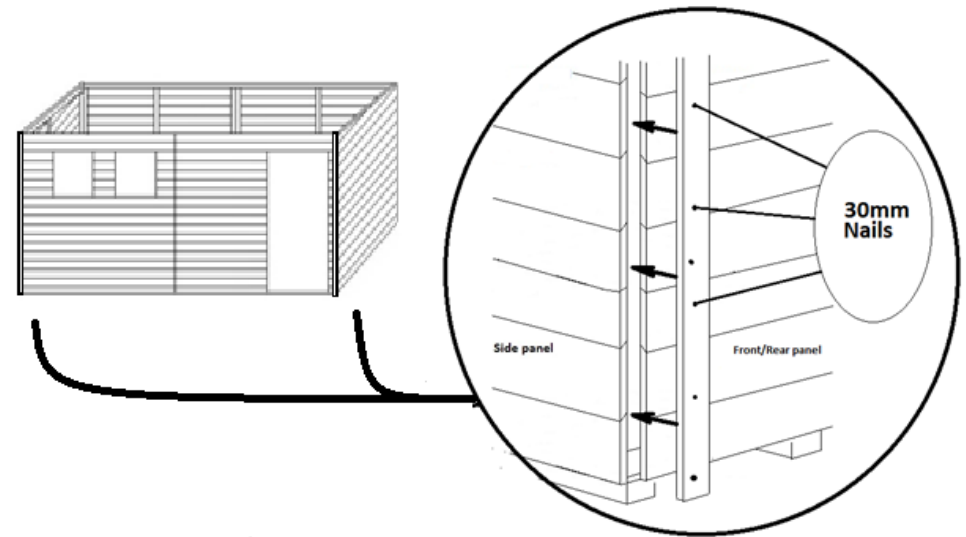

Position the corner cover strips as shown above and fix with 30mm nails.

### Step.6

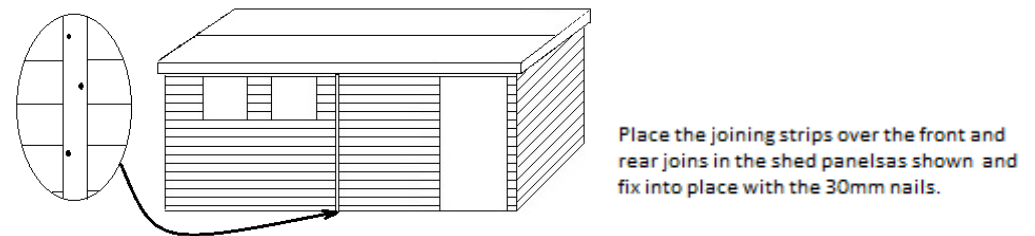

Place the joining strips over the front and rear joins in the shed panels as shown and fix into place with the 30mm nails.

Position the joining strips over the front and rear joins in the shed panels and fix with the 30mm nails as shown.

### 3. Roof

The roof board(s) have been supplied with the batons attached.

#### Step.1

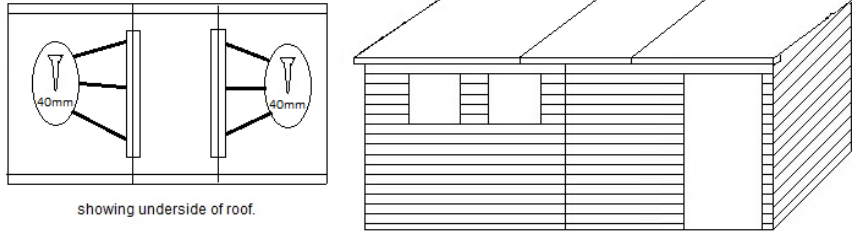

Lay each section of the roof on top of the shed, the shorter batons should be on the inside. Fix together the three sections using the 40mm screws as shown above.

#### Step.2

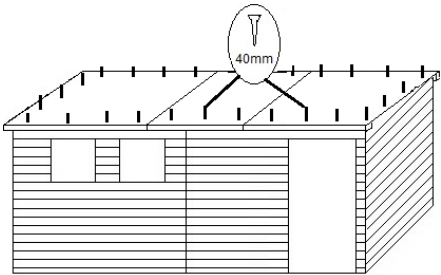

Align the roof so that it overhangs on all sides. Using the 40mm screws, fix the roof panel by screwing through it and into the framework of the shed.

Position each of the additional roof batons, so that they run parallel to the existing roof batons and support the centre of each roof board.

To secure the internal roof batons into place, use 60mm screws, to screw through from the outside of the shed into both ends of the internal roof batons.

#### Step.3

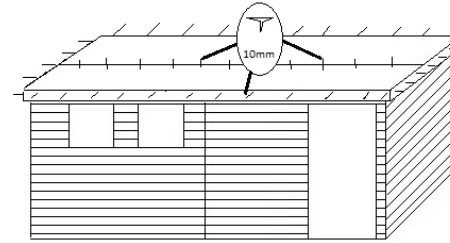

Roll the felt onto the roof, if you have more than one length of felt begin at the lower part of the roof. Make sure that felt is overhanging three sides of the shed. Start at one end, using the 10mm clout nails, fold the felt over the side of the roof and secure with clout nails. Work your way along the roof, taking care to remove wrinkles in the felt as you go. Use one clout nail every approx. 20cms. If you have two or more lengths of felt, position the 2nd length over the remaining part of the roof, making sure to overlap the first length of felt by at least 20cms. Secure the felt as before.

#### Step.4

Take the two shorter barge boards and fix them to the sides of the roof using the 30mm nails. Start by fixing one end of the barge board onto the baton of the roof board, then do the same at the other end. Then work your way along the barge board, securing the nails into the roof board.

Follow the same instruction as above for the front and rear barge boards.

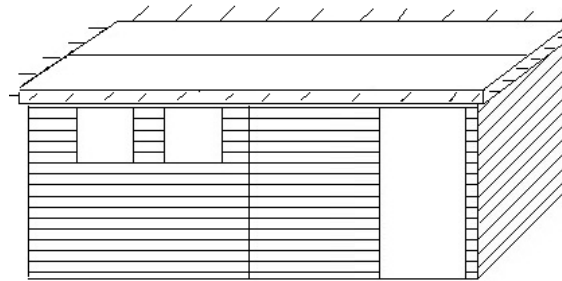

#### 4. Doors

Lie the door on a flat surface with the cladding facing upwards. Take one T hinge and position on the door as shown below, making sure that the T hinge is directly above the brace on the underside of the door. Fix the T hinge into place with the 25mm black screws. Repeat for the next T hinge. With the T hinges secured, position the door squarely in the door frame. Fix the top hinge first and the bottom hinge second with the 25mm black screws. Make sure that the door can open and close freely.

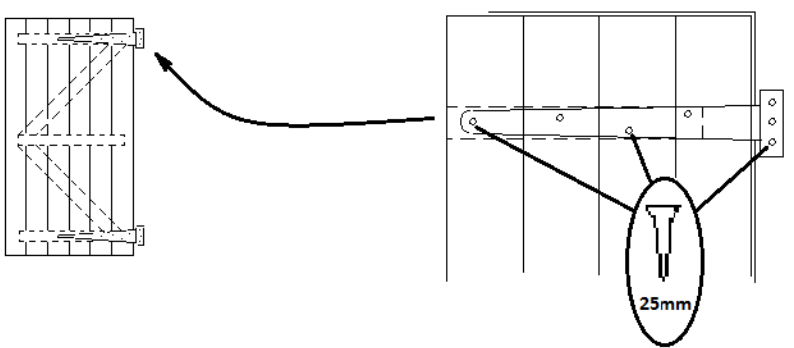

#### Important Information

Adequate provision must be made to ensure that the building does not come into direct contact with the ground and air is able to circulate underneath. A concrete or paving slab base is acceptable, but the building must not be allowed to sit in pooled water during wet conditions.

**Timber Information.** Timber is a natural product and can therefore be subject to warping, shrinkage, splitting etc...Periods of excessive dry spells can cause the timber to lose internal moisture resulting in shrinkage on a panel. During periods of excessive wet spells, the timber may experience some swelling. Unfortunately this process cannot be avoided. If you have problems with certain boards shrinking, try to decrease the amount of direct sunlight it gets. During hot spells spray any shrunken boards with a hosepipe, this will replenish the moisture in the timber.

If you have any questions or queries during the assembly of your building please contact us:-

**HELP LINE: 01384 897257**

We are constantly improving and updating the quality of our products and as such some components may differ from those shown. We reserve the right to change the specification of our products without prior notice.

#### 5. Windows (optional)

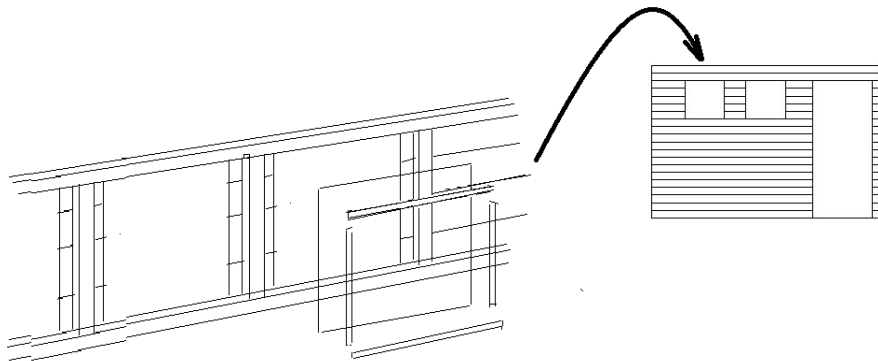

To fit the windows it is recommended that a waterproof sealant is applied around the edge of the glazing before fitting. From the inside of the building fit the styrene window into the frame and secure in place with the 4 strips of window bead. Fix the window bead to the window frame with 30mm panel pins.