

**MAGNETIC RECUMBENT BIKE  
ROWER**

**CONVERSION®**



**9003**

# Owner's Manual

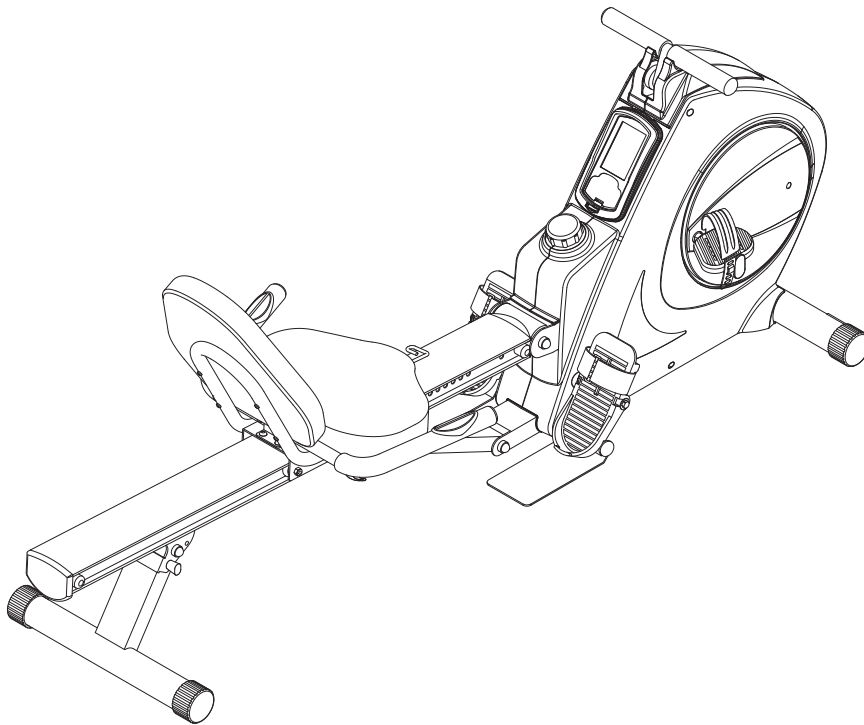

Product May Vary Slightly From Pictured.

**CAUTION:**

Weight on this product should not exceed 250 lbs.

**⚠ WARNING**

Exercise can present a health risk. Consult a physician before beginning any exercise program with this equipment. If you feel faint or dizzy, immediately discontinue use of this equipment. Serious bodily injury can occur if this equipment is not assembled and used correctly. Serious bodily injury can also occur if all instructions are not followed. Keep others and pets away from equipment when in use. Always make sure all bolts and nuts are securely tightened prior to each use. Follow all safety instructions in this manual.

When calling for parts or service, please specify the following number:

**Model#: 15-9003B**

This Product is Distributed Exclusively by



2040 N. Alliance, Springfield, MO 65803

Customer Service

1 (800) 375-7520

[www.staminaproducts.com](http://www.staminaproducts.com)

**STAMINA PRODUCTS  
MADE IN TAIWAN**

© 2011 Stamina Products, Inc.  
2011, 08

## TABLE OF CONTENTS

Safety Instructions .....	2	Storage .....	17
Before You Begin .....	4	Conditioning Guidelines .....	18
Equipment Warning, Caution & Notice Labels ...	5	Warm-Up and Cool-Down .....	19
Hardware Identification Chart .....	6	Product Parts Drawing .....	20
Assembly Instructions .....	7	Parts List .....	21
Set Up Instructions .....	11	Warranty .....	24
Operational Instructions .....	12	Notes .....	25
Maintenance .....	16	Fax/Mail Ordering Form .....	26

## SAFETY INSTRUCTIONS

**⚠ WARNING** This product contains a chemical known to the State of California to cause cancer and birth defects or other reproductive harm.

**⚠ CAUTION** Consult your physician before starting this or any exercise program. This is especially important if you are over the age of 35, have never exercised before, are pregnant, or suffer from any health problem. This product is for home use only. Do not use in institutional or commercial applications. Failure to follow all warnings and instructions could result in bodily injury and property damage.

**⚠ WARNING** To reduce the risk of serious injury, read the following Safety Instructions before using the Conversion II ® 9003.

1. Read all warnings and cautions posted on the **Conversion II ® 9003**.
2. The **Conversion II ® 9003** should only be used after a thorough review of the Owner's Manual.
3. We recommend that two people be available for assembly of this product.
4. Keep children away from the **Conversion II ® 9003**. Do not allow children to use or play on the **Conversion II ® 9003**. Keep children and pets away from the **Conversion II ® 9003** when it is in use.
5. It is recommended that you place this exercise equipment on an equipment mat.
6. Set up and operate the **Conversion II ® 9003** on a solid level surface. Do not position the **Conversion II ® 9003** on loose rugs or uneven surfaces.
7. Make sure that adequate space is available for access to and around the **Conversion II ® 9003**.
8. Make sure the Rear Support(62) is locked properly with the Pull Pin(63) before using the **Conversion II ® 9003**.
9. Make sure the Rail(52) is locked properly by the Release Knob(59) located on the Support Tube(56) when in storage.
10. Keep fingers clear of all pinch points when folding and unfolding the **Conversion II ® 9003**.
11. Lock seat in position with at least one adjustment hole visible in front of the seat before lifting rail to storage position. This will prevent the seat from damaging the covers.
12. Before using, inspect the **Conversion II ® 9003** for worn or loose components, and securely tighten or replace any worn or loose components prior to use.
13. Each user should adjust the seat per instructions on page 12.
14. Do not attempt to adjust the seat while you are on the **Conversion II ® 9003**.
15. Consult a physician prior to commencing an exercise program and follow his/her recommendations in developing your fitness program. If at any time during exercise you feel faint, dizzy, or experience pain, stop and consult your physician.
16. Always choose the workout which best fits your physical strength and flexibility level. Know your limits and train within them. Always use common sense when exercising.
17. Do not wear loose or dangling clothing while using the **Conversion II ® 9003**.
18. Never exercise in bare feet or socks; always wear proper footwear such as running, walking, or cross training shoes that fit well, provide foot support, and feature non-skid rubber soles.
19. Be careful to maintain your balance while using, mounting, dismounting, or assembling the **Conversion II ® 9003**, loss of balance may result in a fall and bodily injury.
20. The **Conversion II ® 9003** should not be used by persons weighing over 250 pounds.
21. The **Conversion II ® 9003** should be used by only one person at a time.
22. The **Conversion II ® 9003** is for consumer use only. It is not for use in public or semipublic facilities.

# Call Us First



**Customer Service**  
**1 (800) 375-7520**  
**www.staminaproducts.com**

## THANK YOU FOR PURCHASING THE Conversion II ® 9003

To enact your warranty, please register your product  
by going to [register.staminaproducts.com](http://register.staminaproducts.com)

To help you get started, we have pre-assembled most of your  
Conversion II ® 9003 at the factory with the exception  
of those few parts left unassembled for shipping purposes.  
Simply follow the few assembly instructions set forth in this manual.  
With regular workouts, you will be getting your body into shape  
and be on your way to achieving a happier and healthier lifestyle.

Should you have any questions,  
please call our Customer Service Department toll-free number,  
**1 (800) 375-7520**  
Monday - Thursday, 7:30 A.M. - 5:00 P.M., Central Time.  
Friday, 8:00 A.M. - 3:00 P.M., Central Time.



**ONLINE**  
CUSTOMER SERVICE  
[customerservice@staminaproducts.com](mailto:customerservice@staminaproducts.com)  
[www.staminaproducts.com](http://www.staminaproducts.com)



**TELEPHONE**  
CUSTOMER SERVICE  
Tel: 1 (800) 375-7520



**FAX**  
CUSTOMER SERVICE  
Fax: (417) 889-8064



**MAIL**  
STAMINA PRODUCTS, INC.  
ATTN: Customer Service  
P.O. Box 1071  
Springfield, MO. 65801-1071



## BEFORE YOU BEGIN

Thank you for choosing the **Conversion II® 9003**. We take great pride in producing this quality product and hope it will provide many hours of quality exercise to make you feel better, look better, and enjoy life to its fullest.

It's a proven fact that a regular exercise program can improve your physical and mental health. Too often, our busy lifestyles limit our time and opportunity to exercise. The **Conversion II® 9003** provides a convenient and simple method to begin your assault on getting your body in shape and achieving a happier and healthier lifestyle.

Before reading further, please review the drawing below and familiarize yourself with the parts that are labeled.

Read this manual carefully before using the **Conversion II® 9003**.

Although Stamina constructs its products with the finest materials and uses the highest standards of manufacturing and quality control, there can sometimes be missing parts or incorrectly sized parts. If you have any questions or problems with the parts included with your **Conversion II® 9003**, please do not return the product. Contact us **FIRST!**

If a part is missing or defective, please go to [staminaproducts.com](http://staminaproducts.com) to the Services section and order the part needed, or call us toll free at 1-800-375-7520 (in the U.S.). Our Customer Service Staff is available to assist you from 7:30 A.M. to 5:00 P.M. (Central Time) Monday through Thursday and 8:00 A.M. to 3:00 P.M. (Central Time) on Friday.

Be sure to have the name and model number of the product available when you contact us.

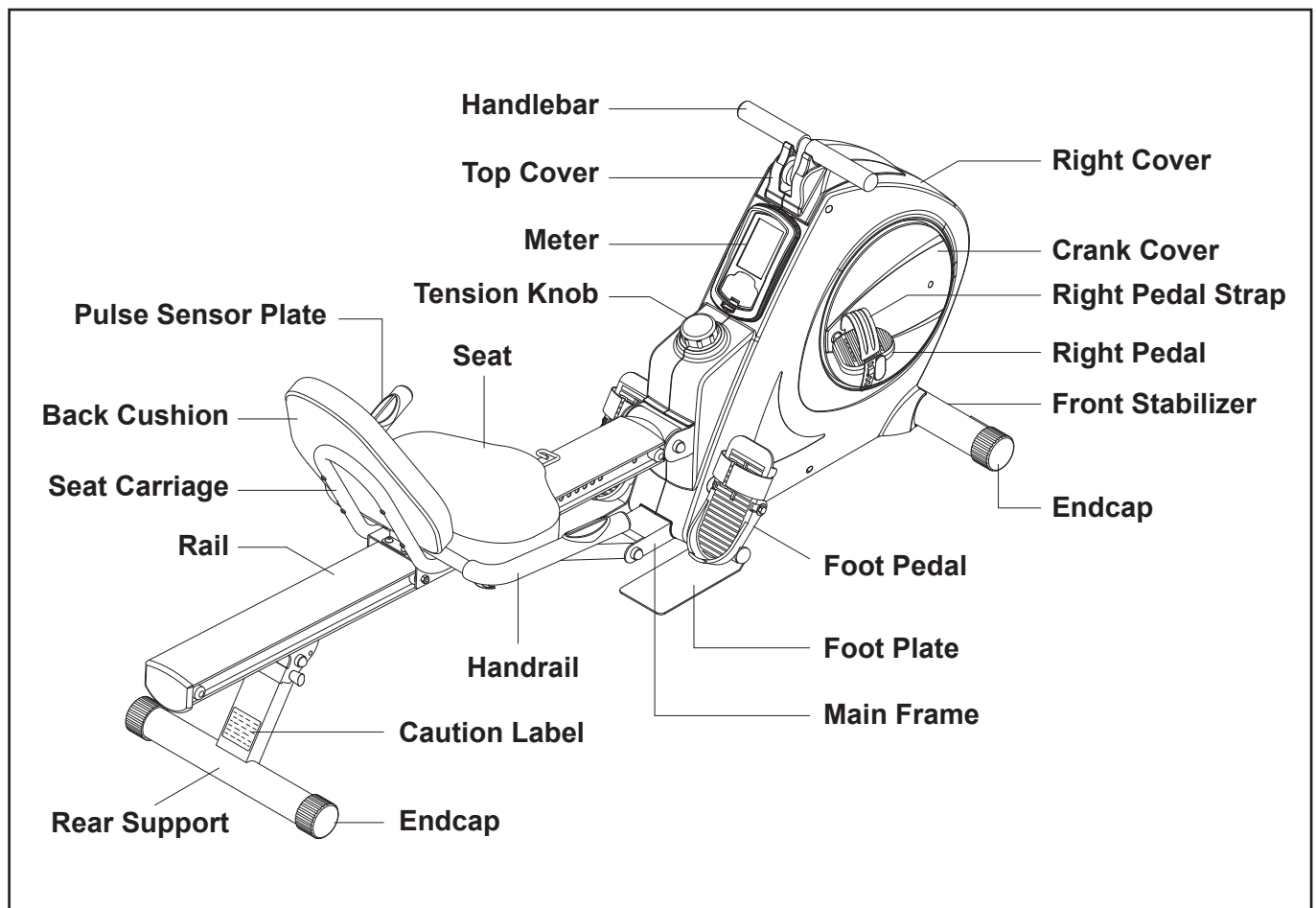

THE FOLLOWING TOOLS ARE INCLUDED FOR ASSEMBLY :



## EQUIPMENT WARNING, CAUTION & NOTICE LABELS

This chart is provided to help identify the warning, caution, and notice labels on the **Conversion II® 9003**. Please take a moment to familiarize yourself with all of the warning, caution, and notice labels.

Label is larger than actual size

### **C1** CAUTION LABEL(129)



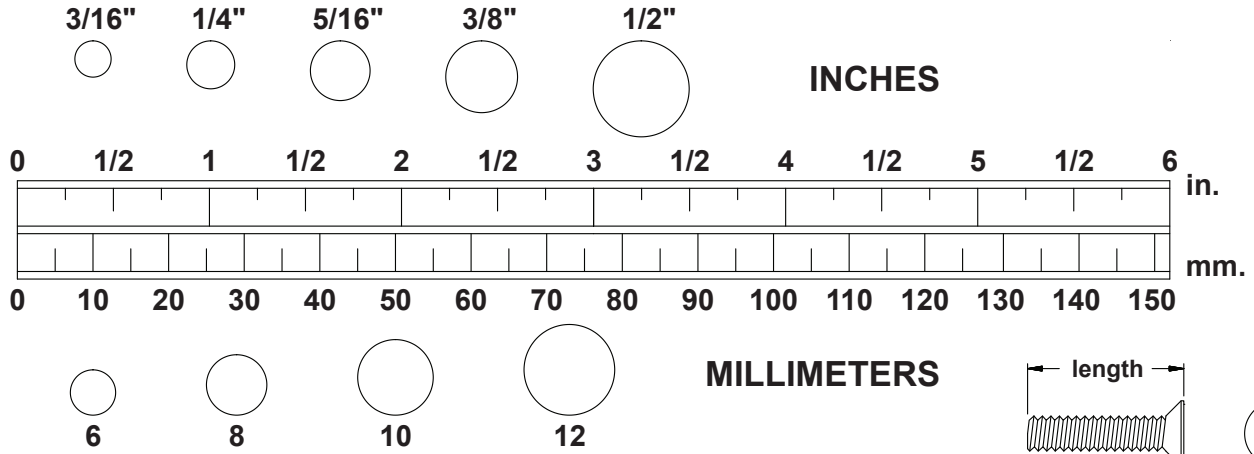

# HARDWARE IDENTIFICATION CHART

This chart is provided to help identify the hardware used in the assembly process. Place the washers or the ends of the bolts or screws on the circles to check for the correct diameter. Use the small scale to check the length of the bolts and screws.

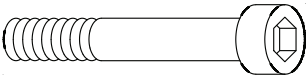
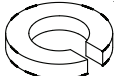
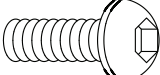
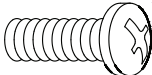
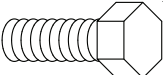
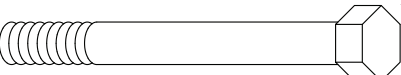

**NOTICE:** The length of all bolts and screws, except those with flat heads, is measured from below the head to the end of the bolt or screw. Flat head bolts and screws are measured from the top of the head to the end of the bolt or screw.

After unpacking the unit, open the hardware bag and make sure that you have all the following items. Some hardware may be already attached to the part.

	Part No. and Description	Qty
	81 Bolt, Socket Head (M8 x 1.25 x 70mm)	2
	89 Lock Washer (M8)	2
	94 Bolt, Button Head (M8 x 1.25 x 15mm)	3
	114 Bolt, Button Head (M8 x 1.25 x 12mm)	4
	95 Bolt, Round Head (M6 x 1 x 15mm)	4
	96 Bolt, Round Head (M6 x 1 x 30mm)	4
	97 Bolt, Hex Head (M8 x 1.25 x 16mm)	4
	101 Bolt, Hex Head (M10 x 1.5 x 85mm)	1
	102 Bolt, Hex Head (M10 x 1.5 x 95mm)	1
	103 Bolt, Hex Head (M10 x 1.5 x 125mm)	1
	105 Nylock Nut (M10 x 1.5)	3
	109 Large Washer (M8 x ø23 )	2

## ASSEMBLY INSTRUCTIONS

Place all parts from the box in a cleared area and position them on the floor in front of you. Remove all packing materials from your area and place them back into the box. Do not dispose of the packing materials until assembly is completed. Read each step carefully before beginning. If you are missing a part, please go to [staminaproducts.com](http://staminaproducts.com) to the Services section and order the part needed, e-mail us at [customerservice@staminaproducts.com](mailto:customerservice@staminaproducts.com), or call us toll free at 1-800-375-7520 (in the U.S.). Our Customer Service Staff is available to assist you from 7:30 A.M. to 5:00 P.M. (Central Time) Monday through Thursday and 8:00 A.M. to 3:00 P.M. (Central Time) on Friday.

**STEP 1:** There is an “R” decal on one end of the **FRONT STABILIZER(2)**. Attach the **FRONT STABILIZER(2)** to the **MAIN FRAME(1)** with the “R” decal end at right side and secure with **SOCKET HEAD BOLTS (M8x1.25x70mm)(81)** and **LOCK WASHERS(M8)(89)**.

**STEP 2:** Insert the **STOPPER TUBE(48)** through the **MAIN FRAME(1)** and secure with **BUTTON HEAD BOLT(M8x1.25x15mm)(94)**. Slide the **FOOT PLATES(116)** on both sides of the **STOPPER TUBE(48)**. Press the **DOME PLUGS(25mm)(78)** into both ends of the **STOPPER TUBE(48)**.

**NOTE:** The **PEDAL STRAPS(47)** are pre-assembled and attached to the **FOOT PEDALS(46)**. The pedal and strap assembly for the left side has an “L” decal. The pedal and strap assembly for the right side has an “R” decal.

**STEP 3:** Insert the **PEDAL SHAFT(44)** through the **MAIN FRAME(1)**. Place the **RIGHT FOOT PEDAL ASSEMBLY(46R)** onto the right end of the **PEDAL SHAFT(44)** and place the **LEFT FOOT PEDAL ASSEMBLY(46L)** onto the left end. Secure the **FOOT PEDALS** with **BUTTON HEAD BOLTS (M8x1.25x15mm)(94)** and **LARGE WASHERS(M8)(109)** at both ends of the **PEDAL SHAFT(44)**.

**NOTE:** You need to use two Allen Wrenches to tighten the **BUTTON HEAD BOLTS(M8x1.25x15mm)(94)** at both ends of the **PEDAL SHAFT(44)** at the same time.

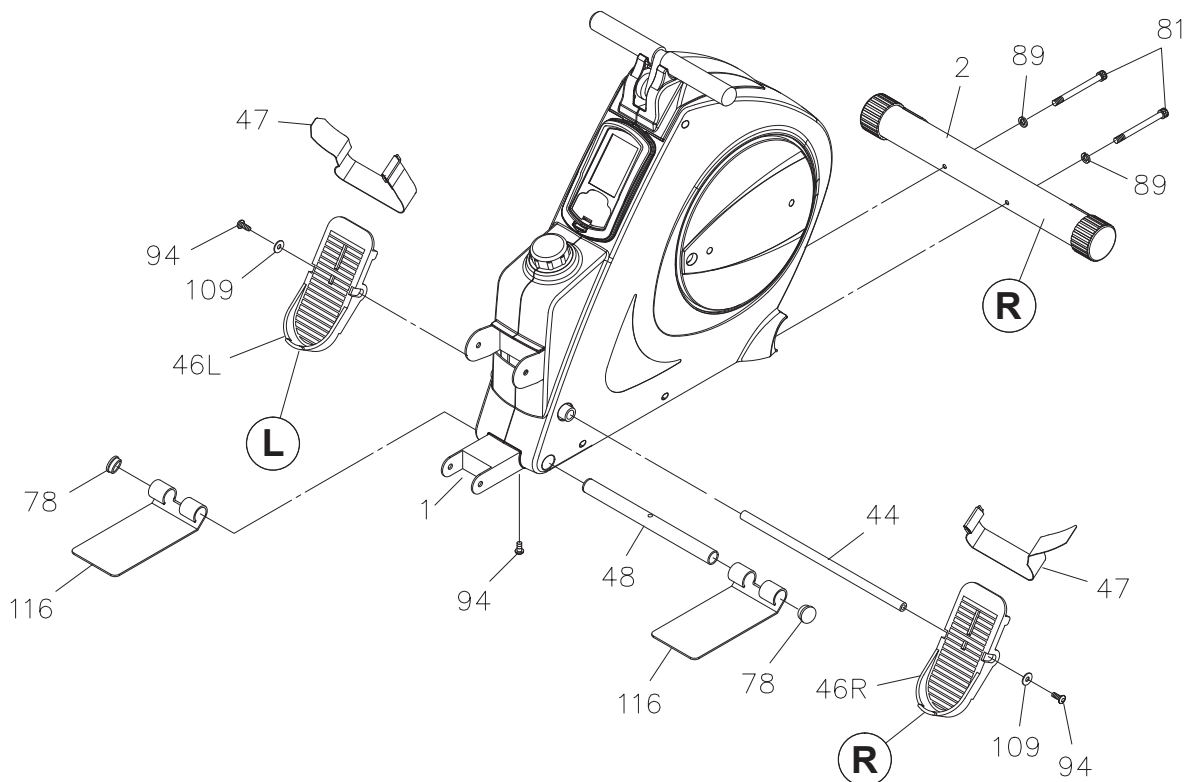

## ASSEMBLY INSTRUCTIONS

### STEP 4

Attach the **SUPPORT BRACKET(60)** to the **RAIL(52)** with **HEX BOLTS(M8x1.25x16mm)(97)**. Press the **NUT CAPS(79)** onto **NYLOCK NUT(M10x1.5)(105)** and **HEX BOLT(M10x1.5x75mm)(100)**.

### STEP 5

Attach the **RAIL(52)** onto the **MAIN FRAME(1)** by sliding the **RAIL PIVOT(49)** into the bracket on the **MAIN FRAME(1)** and securing with **HEX BOLT(M10x1.5x125mm)(103)** and **NYLOCK NUT(M10x1.5)(105)**. Press the **NUT CAPS(79)** onto **HEX BOLT(M10x1.5x125mm)(103)** and **NYLOCK NUT(M10x1.5)(105)**.

### STEP 6

Connect the lower end of the **SUPPORT TUBE(56)** to the **MAIN FRAME(1)** with **HEX BOLT(M10x1.5x85mm)(101)** and **NYLOCK NUT(M10x1.5)(105)**. Press the **NUT CAPS(79)** onto **HEX BOLT(M10x1.5x85mm)(101)** and **NYLOCK NUT(M10x1.5)(105)**.

### STEP 7

Attach the **REAR SUPPORT(62)** to the **REAR SUPPORT BRACKET(61)** located on the **RAIL(52)** with **HEX BOLT(M10x1.5x95mm)(102)** and **NYLOCK NUT(M10x1.5)(105)**. Lock the **REAR SUPPORT(62)** in position with the **PULL PIN(63)**. Press the **NUT CAPS(79)** onto **HEX BOLT(M10x1.5x95mm)(102)** and **NYLOCK NUT(M10x1.5)(105)**.

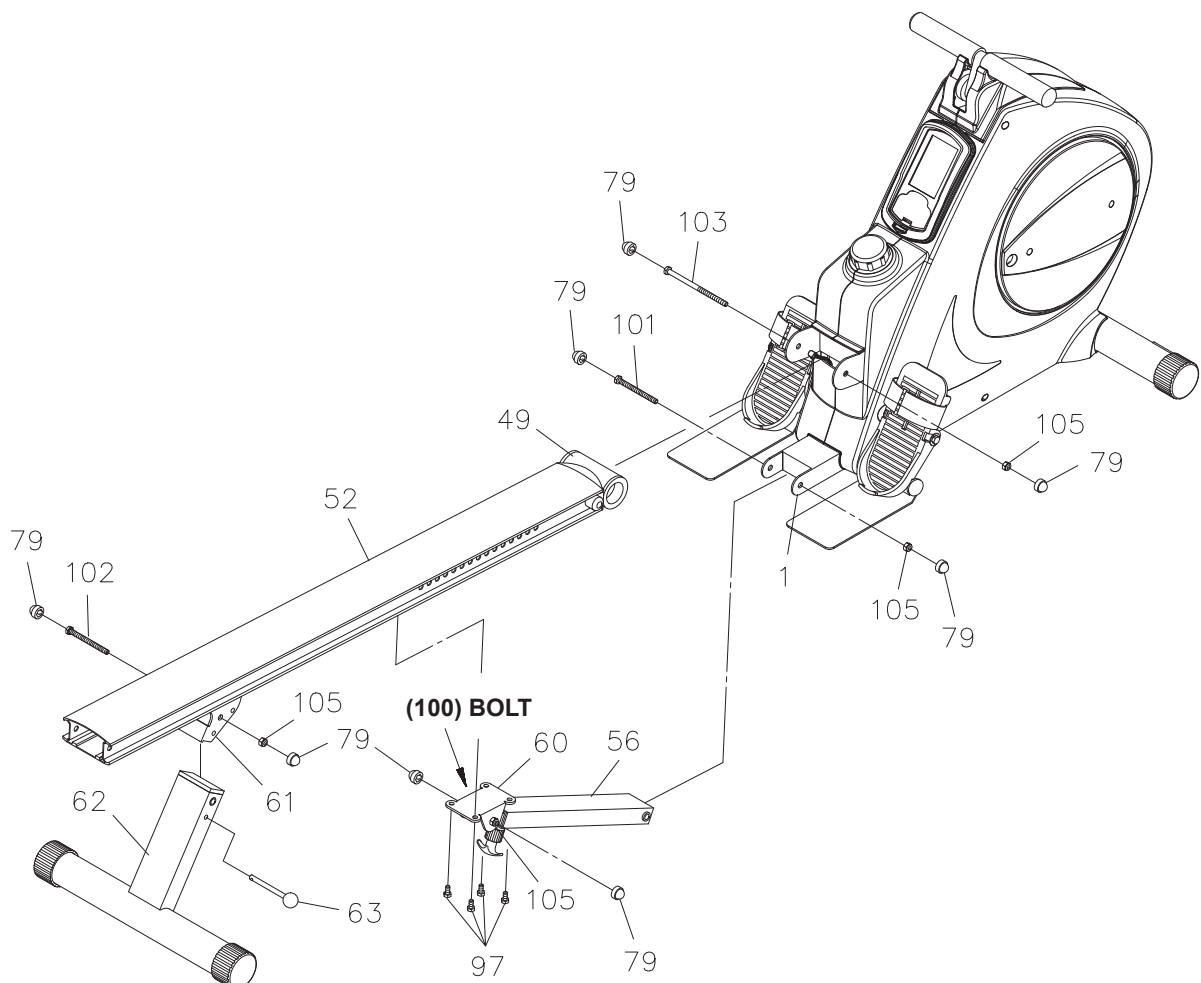



## ASSEMBLY INSTRUCTIONS

**NOTE:** Be careful not to damage the **PULSE SENSOR WIRE(73)** or **PULSE COIL WIRE(74)** during assembly steps 8, 9, and 10.

### STEP 8

Attach the **HANDRAIL(70)** to the **SEAT CARRIAGE(64)** with **BUTTON HEAD BOLTS (M8x1.25x12mm) (114)**.

### STEP 9

Attach the **SEAT(68)** to the **SEAT CARRIAGE(64)** with **ROUND HEAD BOLTS(M6x1x15mm)(95)**. Attach the **BACK CUSHION(69)** to the **SEAT CARRIAGE(64)** with **ROUND HEAD BOLTS(M6x1x30mm)(96)**.

### STEP 10

Turn the knob of the **SPRING PIN(67)** counterclockwise and lock the knob in the release position, refer to the inset drawing. Slide the **SEAT CARRIAGE ASSEMBLY(64)** into the **RAIL(52)**. Press the **RAIL CAP(55)** into the back end of the **RAIL(52)**. Insert the **STOPPER BOLT(54)** through the **RAIL(52)** and **RAIL CAP(55)** to bolt them together with the **STOPPER(53)**. Please verify that the other **STOPPER BOLT(54)** at the front end of **RAIL(52)** was assembled at the factory.

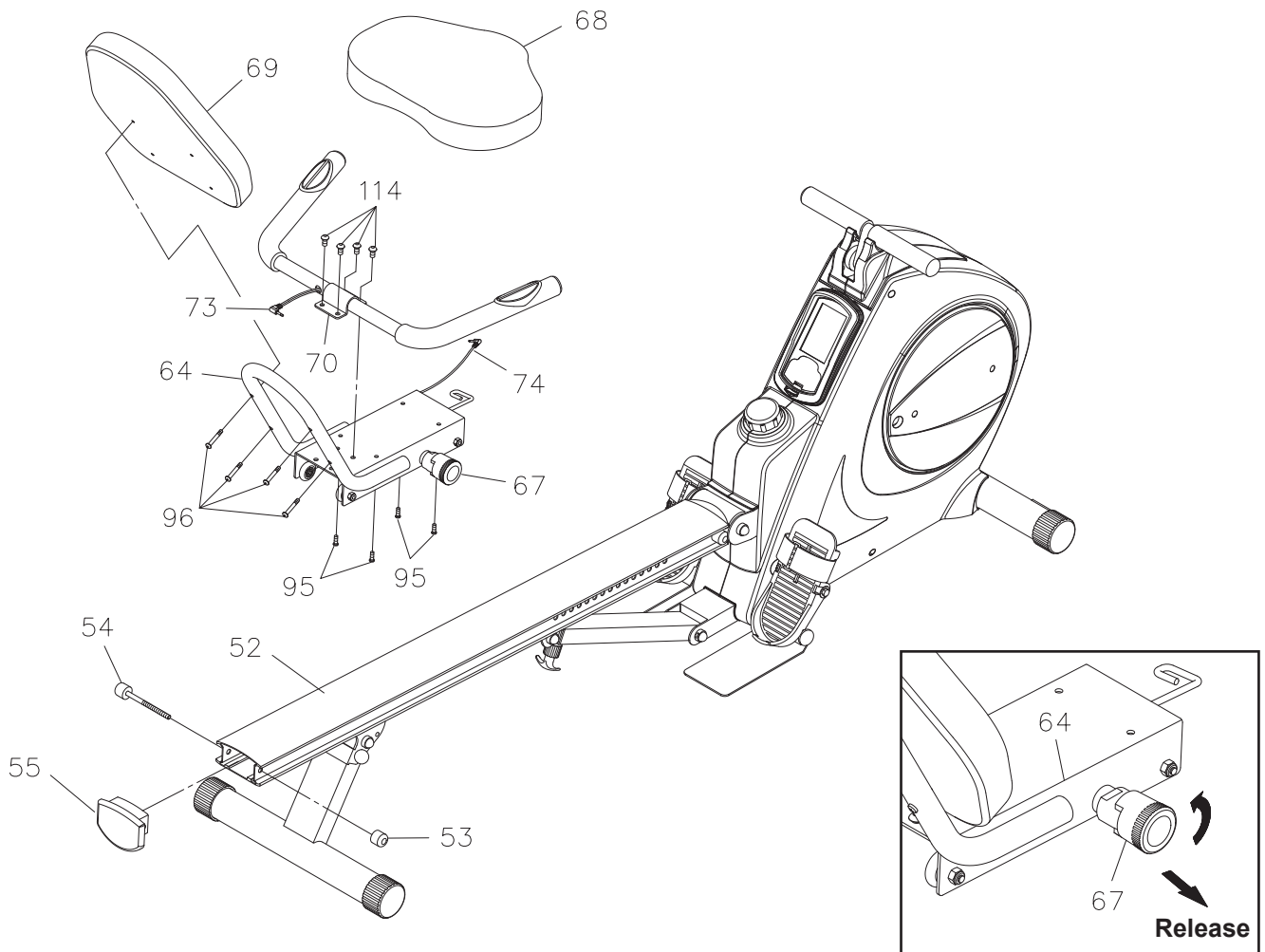

## ASSEMBLY INSTRUCTIONS

### STEP 11

**NOTE:** The **RIGHT PEDAL(41)** has **R** stamped on the end of the pedal shaft. The **RIGHT PEDAL(41)** has right hand threads and is tightened by turning clockwise. The **LEFT PEDAL(39)** has **L** stamped on the end of the pedal shaft. The **LEFT PEDAL(39)** has left hand threads and is tightened by turning counterclockwise.

Thread the **RIGHT PEDAL(41)** into the **RIGHT CRANK(37)** located inside the **CRANK COVER(35)** as shown. Tighten the pedal securely. Select the **RIGHT PEDAL STRAP(42)** which has **R** marked on the bottom side of the strap. Snap the three hole end to the inside edge of the **RIGHT PEDAL(41)**. Snap the other end to the outside edge of the **RIGHT PEDAL(41)** with the **R** mark on the bottom of the **RIGHT PEDAL STRAP(42)**. Select adjustment holes which allow your foot to be easily removed from the pedals. Repeat on the left side in order to attach the **LEFT PEDAL(39)** to the **LEFT CRANK(36)** and snap the **LEFT PEDAL STRAP(40)** to the **LEFT PEDAL(39)**.

### STEP 12

Refer to the inset drawing. Plug the **PULSE SENSOR WIRE(73)** into the socket of **PULSE COIL WIRE(74)** located on the **SEAT CARRIAGE(64)**. Plug the **PULSE COIL WIRE(74)** into the socket of **PULSE CONNECTION WIRE(75)** located on the bracket on the **MAIN FRAME(1)**.

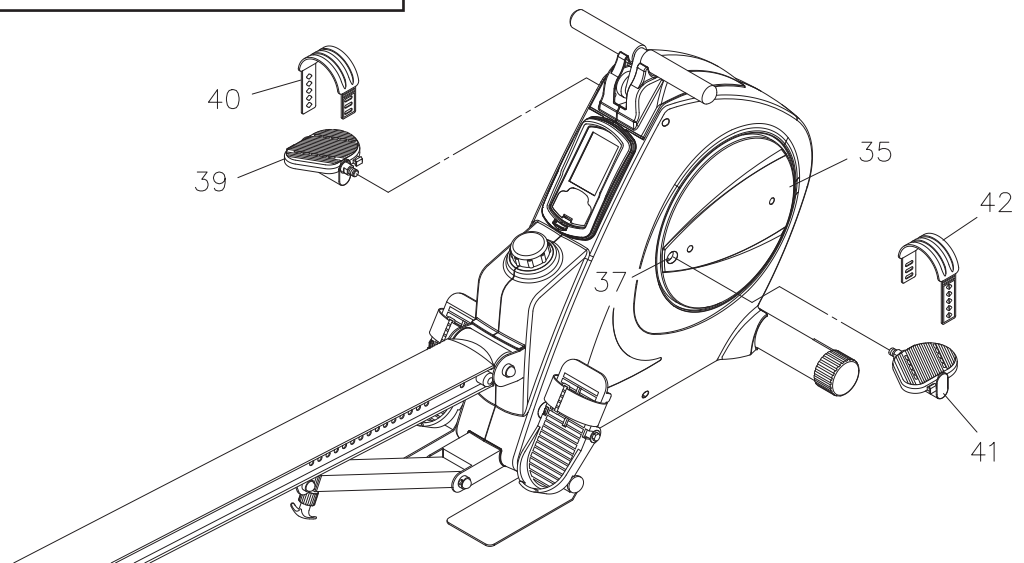
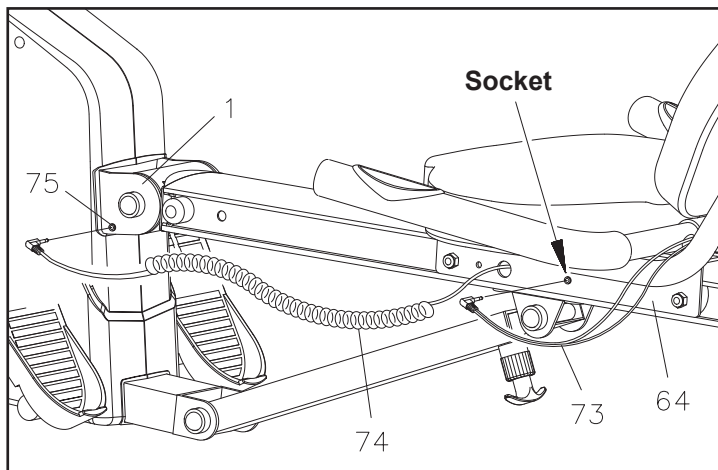

## SET UP INSTRUCTIONS

Place the **Conversion II ® 9003** in the area where it will be used. It is recommended that the **Conversion II ® 9003** be placed on an equipment mat. The **Conversion II ® 9003** is approximately 77.8 inches long x 23 inches wide x 30.6 inches tall. (These dimensions may vary up to one inch.) An area 4 feet wide x 8.5 feet long is required for safe operation of the **Conversion II ® 9003**. Make sure that adequate space is available for access to and passage around the **Conversion II ® 9003**.

**LEVELING:** Adjust the location of **Conversion II ® 9003** so the machine sits on the floor without rocking.

**MOVING:** The **Conversion II ® 9003** has a pair of **MOVING WHEELS(76)** on the **FRONT STABILIZER(2)**. Grasp the **RAIL CAP(55)** to move the **Conversion II ® 9003**.

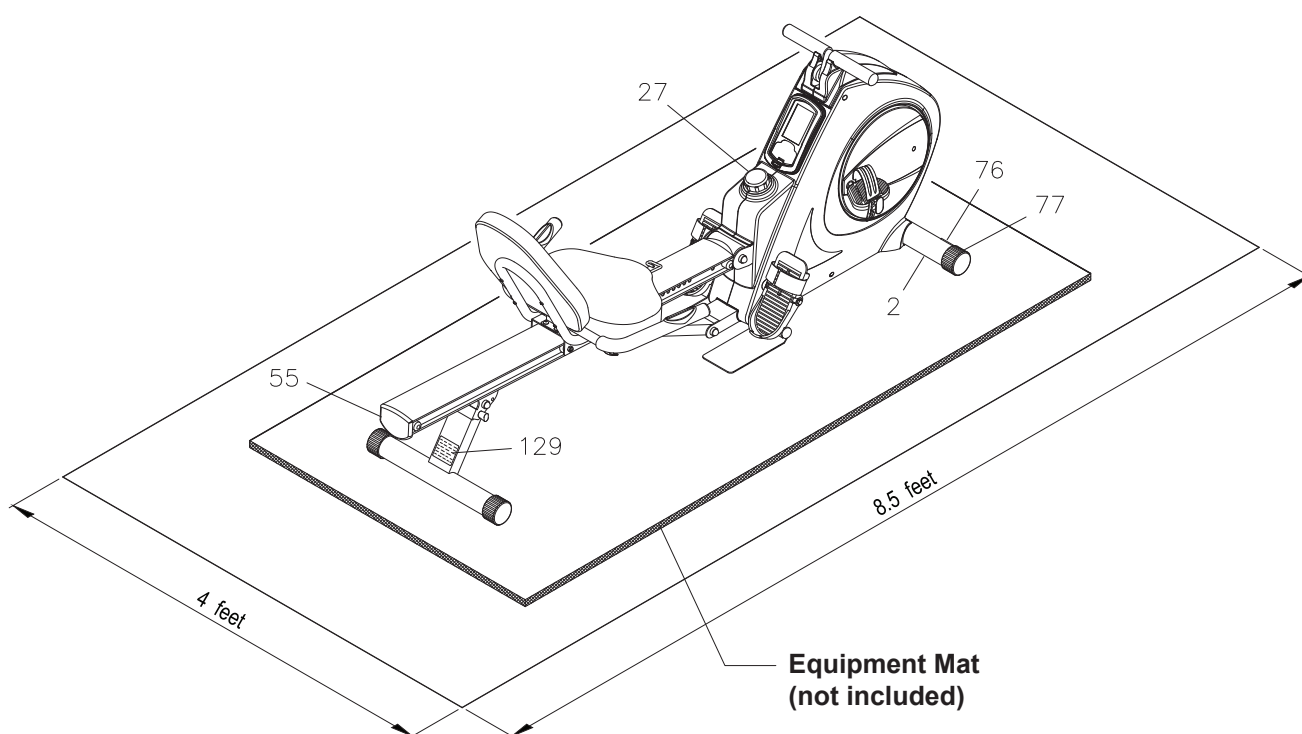

### FUNCTION INSPECTION:

Visually inspect the **Conversion II ® 9003** to verify that assembly is as shown in the above illustration. Check the function of the **Conversion II ® 9003** by turning the crank slowly through one complete revolution to verify that the drive train functions properly. Adjust the **TENSION KNOB(27)** and verify that it functions properly.

**CAUTION:** Locate and read the **CAUTION LABEL(129)** on the **Conversion II ® 9003**. Make sure that all users read the **CAUTION LABEL(129)** before using the product.

## OPERATIONAL INSTRUCTIONS

### USING THE ELECTRONIC METER

**POWER ON:** Pedal movement or press any button.

**POWER OFF:** Automatic shut off after 4 minutes of inactivity.

### FUNCTION BUTTONS :

**ENTER :** Press this button to enter setting mode.

Press and release to select each function for preset target values for TIME, CAL, PULSE, and DIST.

**MODE :** Press and release to select the function to display on the screen.

Press the button and hold it down for two seconds to reset all functions to zero.

**RESET :** In the setting mode, press the button to reset the setting values to zero for TIME, CAL, and DIST.

In the stop mode, press the button to reset the value displaying on the screen to zero for CAL and DIST.

Press the button and hold it down for two seconds to reset all functions to zero.

**▲ & ▼ :** These two buttons for setting target values of TIME, CAL, PULSE, and DIST.

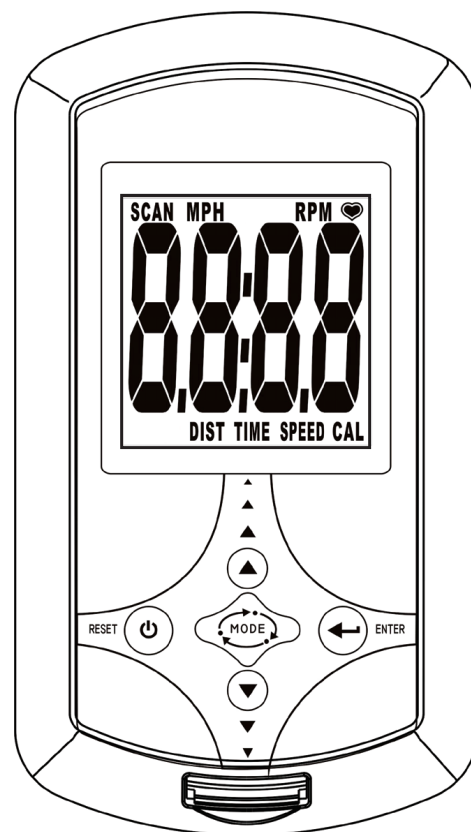

### FUNCTIONS:

**SCAN:** Automatically scans **TIME, SPEED, CALORIE, PULSE, RPM, and DISTANCE** in sequence with a change every six seconds. Press and release the **MODE** button until the “**SCAN**” appear on the display.

**TIME:** Displays the time from 1 sec. up to 99:59 minutes. Counts down from preset value.

**SPEED:** Displays the current speed from zero to 999.9 miles per hour.

**CALORIE:** Displays the calorie consumption from zero to 999.9 Kcal. Counts down from preset value. The calorie readout is an estimate for an average user. It should be used only as a comparison between workouts on this unit.

**PULSE:** Displays your pulse rate in beats per minute. To display pulse, select the PULSE MODE and grasp the pulse sensors on the handlebars, one in each hand. The heart icon will begin flashing when the ELECTRONIC METER senses your pulse. Your pulse will be displayed approximately five (5) seconds after the heart icon is displayed. If the heart icon does not appear, relax your grip or change your grip on the pulse sensors.

If you preset the PULSE value, the meter will warn you with an audible alarm when your pulse exceeds the set value. Stop exercising until your pulse comes down.

**RPM:** Displays crank RPM (revolutions per minute) from zero to 999 rpm.

**DISTANCE:** Displays distance, from the time the meter is turned on, to 999.9 miles. Counts down from preset value.

## OPERATIONAL INSTRUCTIONS

### HOW TO INSTALL AND REPLACE BATTERIES:

1. Squeeze the lug at the bottom on the Meter to open the meter cover.
2. The meter operates with two AA batteries, two batteries included. Refer to the illustration to install or replace the batteries.

### NOTE:

1. Do not mix a new battery with an old battery.
2. Use the same type of battery. Do not mix an alkaline battery with another type of battery.
3. Rechargeable batteries are not recommended.

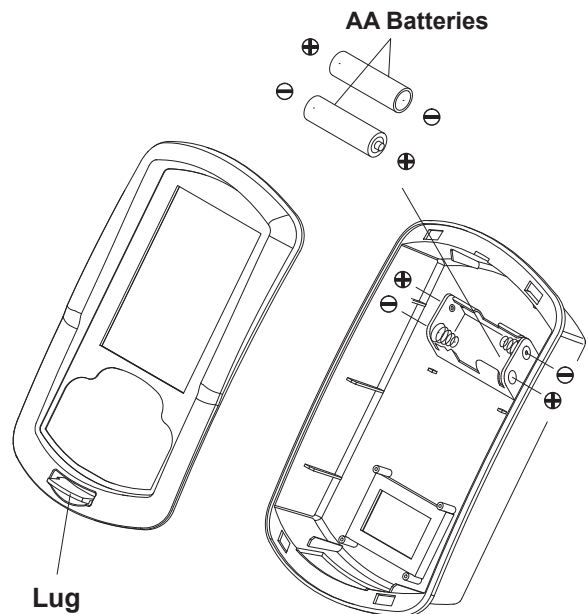

### LOAD ADJUSTMENT

To increase the load, turn the **TENSION KNOB(27)** clockwise. To decrease the load, turn the **TENSION KNOB(27)** counterclockwise. There are eight levels for the load adjustment.

**NOTE:** The load will increase as you pedal faster.

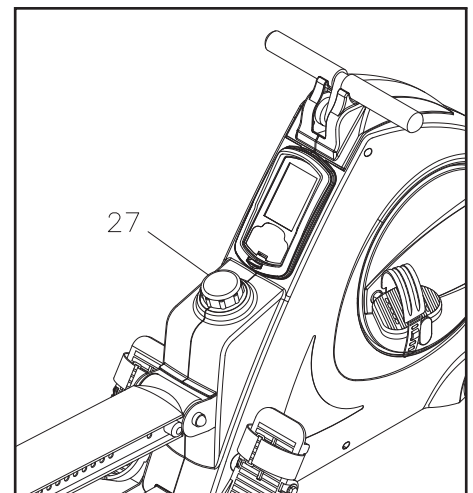

## OPERATIONAL INSTRUCTIONS

### RECUMBENT BIKE MODE AND ROWER MODE

Your **Conversion II ® 9003** can be used in the **Recumbent Bike** mode or the **Rower** mode. When the **SPRING PIN(67)** locks the **SEAT ASSEMBLY** to the **RAIL(52)**, the **Conversion II ® 9003** is in the **Recumbent Bike** mode. When the **SPRING PIN(67)** is in the Release position, the **SEAT ASSEMBLY** is not locked to the **RAIL(52)** and the **Conversion II ® 9003** is in the **Rower** mode.

**RECUMBENT BIKE MODE:** Pull the knob on the **SPRING PIN(67)**, turn it clockwise and release the knob to allow it to lock the seat in position. Sit on the seat and pedal with the **PEDALS(39, 41)**.

**ROWER MODE:** Pull the knob on the **SPRING PIN(67)** and turn it counterclockwise to lock it in the release position. Refer to the inset drawing. This will allow the **SEAT ASSEMBLY** to slide freely on the **RAIL(52)**. To work out, sit on the seat, secure your feet in the **FOOT PEDALS(46)** with the **PEDAL STRAPS(47)** and pull on the **HANDLEBAR(25)**.

**NOTE:** If the **FRONT STABILIZER(2)** raises off the floor during use, adjust the **STAND(43)** to a higher position. The **STAND(43)** is located on the bottom of the **MAIN FRAME(1)**.

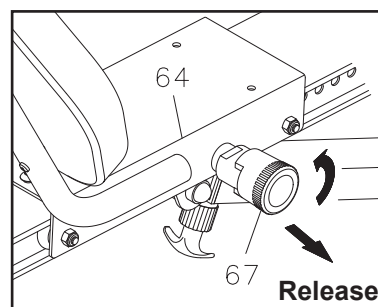
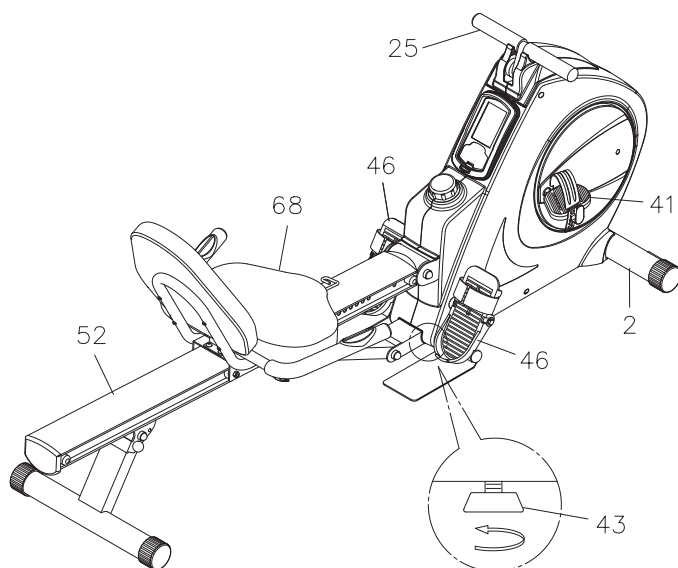

**CAUTION:** Always verify that the **SPRING PIN(67)** is in the correct position before you begin your workout.

### SEAT ADJUSTMENT

Proper seat adjustment is important for **Recumbent Bike** mode.

1. Pull the knob on the **SPRING PIN(67)** and slide the **SEAT ASSEMBLY** forward or backward to adjust the seat. Release the knob on the **SPRING PIN(67)** and make sure it is inserted into one of the adjustment holes in the **RAIL(52)**.
2. Sit on the seat and place your feet on the pedals. You should be able to move through a complete pedal stroke without locking your knees or shifting your hips on the seat. The seat is too close to the pedals if you have more than a slight bend in your knees at the bottom of the pedal stroke. The seat is too far from the pedals if you have to completely straighten your knees at the bottom of the pedal stroke. Refer to the illustrations below.

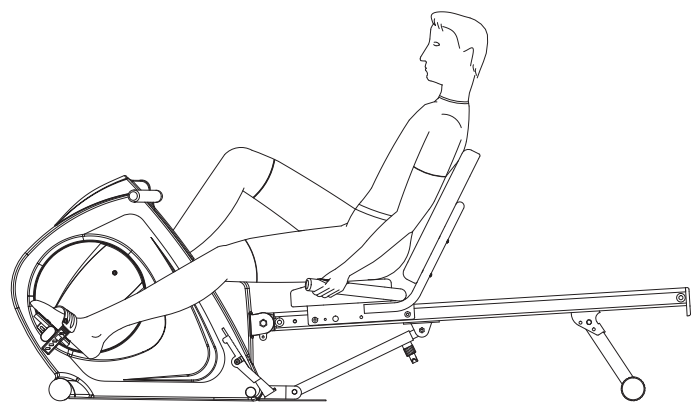

**WARNING:** Do not attempt to adjust the seat while you are on the **Conversion II ® 9003**.

# OPERATIONAL INSTRUCTIONS

## WORKOUT FUNCTIONS

Your **Conversion II® 9003** can be used as the **Rower** or the **Recumbent Bike**. Please workout as following illustrations.

### ROWER

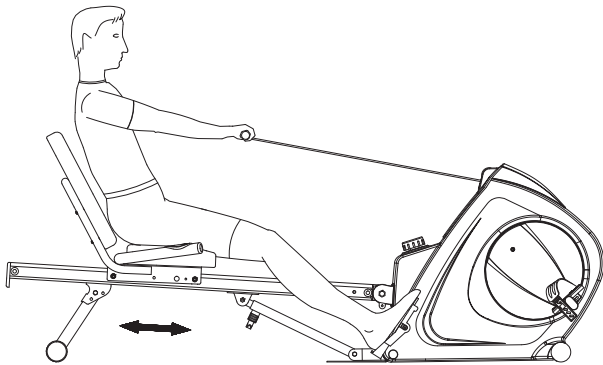

### RECUMBENT BIKE

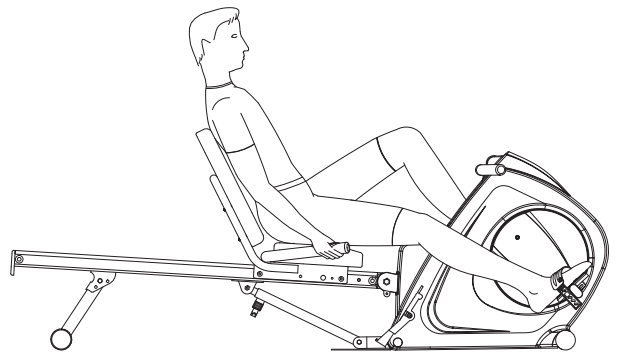

### BACK & ABDOMINAL

Lock the Seat at proper position of rear part of the Rail. By pulling the handlebar in different ways, you can do the following exercises with your **Conversion II® 9003**.

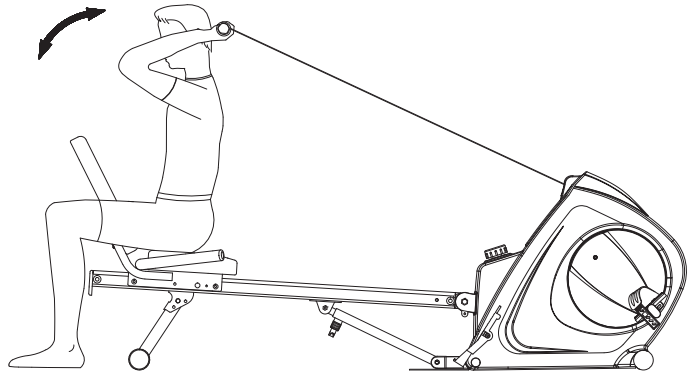

### BICEPS CURL

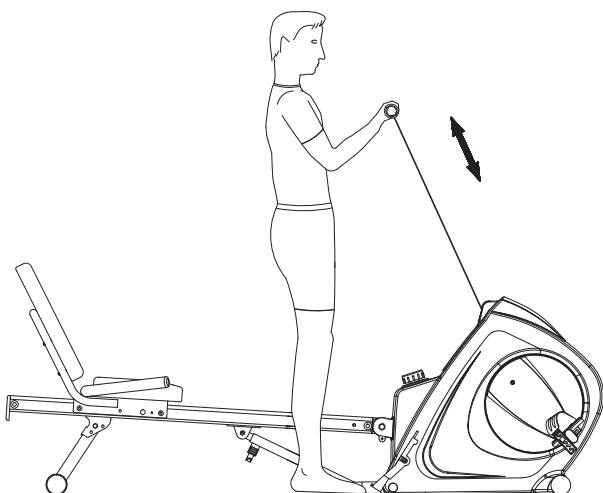

Be sure to step on the iron Foot Plates.

### UPRIGHT ROW

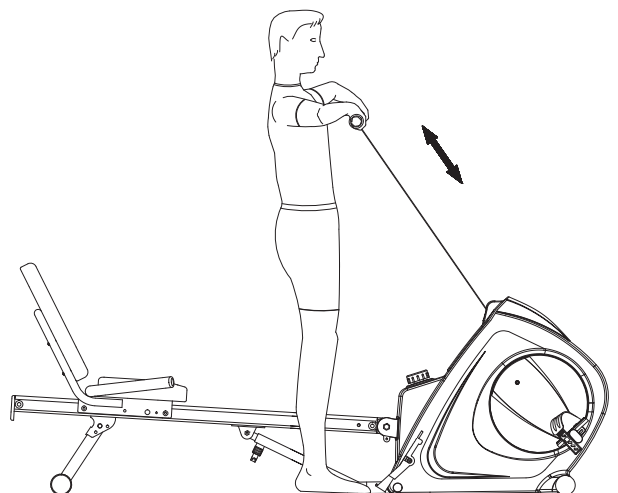

Be sure to step on the iron Foot Plates.

## OPERATIONAL INSTRUCTIONS

### LEG STRETCH

Unlock the Seat from the Rail. Hook the Handlebar to the steel wire Hook at the front of the Seat. You can do the following exercises with your **Conversion II ® 9003**.

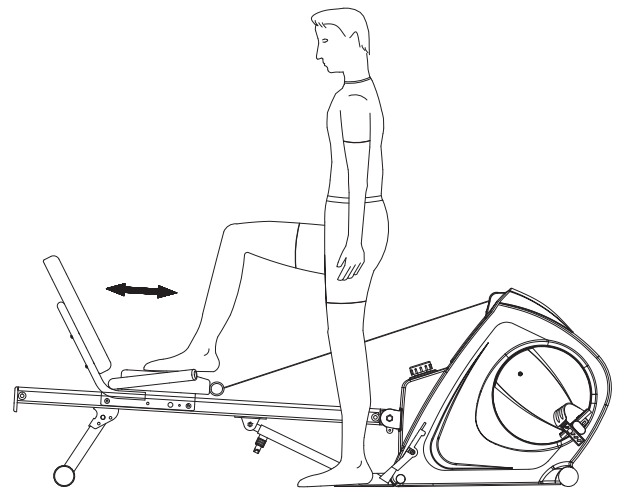

Be sure to step on the iron Foot Plate.

### BUTTOCKS

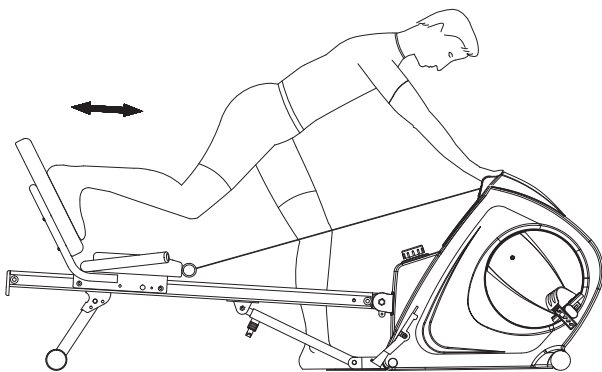

Be sure to step on the iron Foot Plate.

### LEG EXTENSION

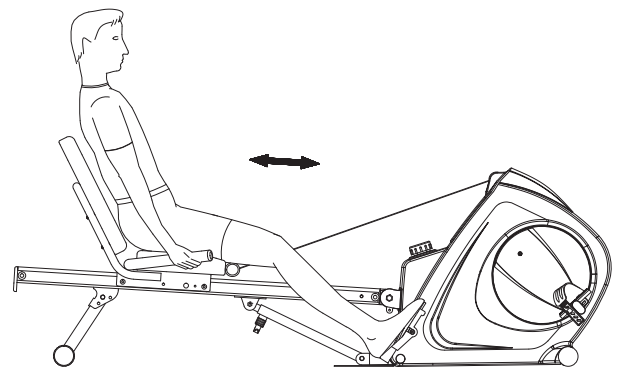

## MAINTENANCE

The safety and integrity designed into the **Conversion II ® 9003** can only be maintained when the **Conversion II ® 9003** is regularly examined for damage and wear. Special attention should be given to the following:

1. Adjust the **TENSION KNOB(27)** and verify that the Magnetic System provides tension. The Magnetic System should provide many years of use.
2. Use a wrench to verify that the pedals are tightened securely. If tightening is required, remember that the left pedal has left hand threads and is tightened by turning counterclockwise.
3. Clean the roller tracks in the **RAIL(52)** with an absorbent cloth.
4. Verify that all nuts and bolts are present and properly tightened. Replace missing nuts and bolts. Tighten loose nuts and bolts.
5. Verify that the **CAUTION LABEL(129)** is in place and easy to read. Call Stamina Products immediately at **1-800-375-7520** for a replacement **CAUTION LABEL(129)** if it is missing or damaged.
6. It is the sole responsibility of the user/owner to ensure that regular maintenance is performed.
7. Worn or damaged components shall be replaced immediately or the **Conversion II ® 9003** removed from service until repair is made.
8. Only Stamina Products supplied components shall be used to maintain/repair the **Conversion II ® 9003**.
9. Keep your **Conversion II ® 9003** clean by wiping it off with an absorbent cloth after use.



## STORAGE

1. To store the **Conversion II® 9003**, simply keep it in a clean dry place.
2. To avoid damage to the electronics, remove the battery before storing the **Conversion II® 9003** for one year or more.
3. Move the **Conversion II® 9003** with the **MOVING WHEELS(76)** on the **FRONT STABILIZER(2)**. Grasp the **RAIL CAP(55)** to move the **Conversion II® 9003**. Do not use the Seat to move the **Conversion II® 9003**. The Seat will move and the Seat Carriage may pinch your hand or fingers.
4. The minimum folded dimensions of the **Conversion II® 9003** are approximately 36.1 inches long x 23 inches wide x 57.8 inches tall. Please measure your **Conversion II® 9003** if exact dimensions are needed.
5. Follow the illustrated process below to fold the **Conversion II® 9003**.
  - a. Adjust and lock the seat in position with at least one adjustment hole visible in front of the seat.  
**NOTE:** This will prevent the seat from damaging the covers.
  - b. Remove the **PULL PIN(63)** and swing the **REAR SUPPORT(62)** toward the front.  
**NOTE:** This will allow you to pull out the **RELEASE KNOB(59)** easily.
  - c. Pull out the **RELEASE KNOB(59)** and fold up the **RAIL(52)**. Make sure the **RAIL(52)** is locked securely in folded position by **RELEASE KNOB(59)**.
  - d. Lock the **REAR SUPPORT(62)** in folded position with the **PULL PIN(63)**.

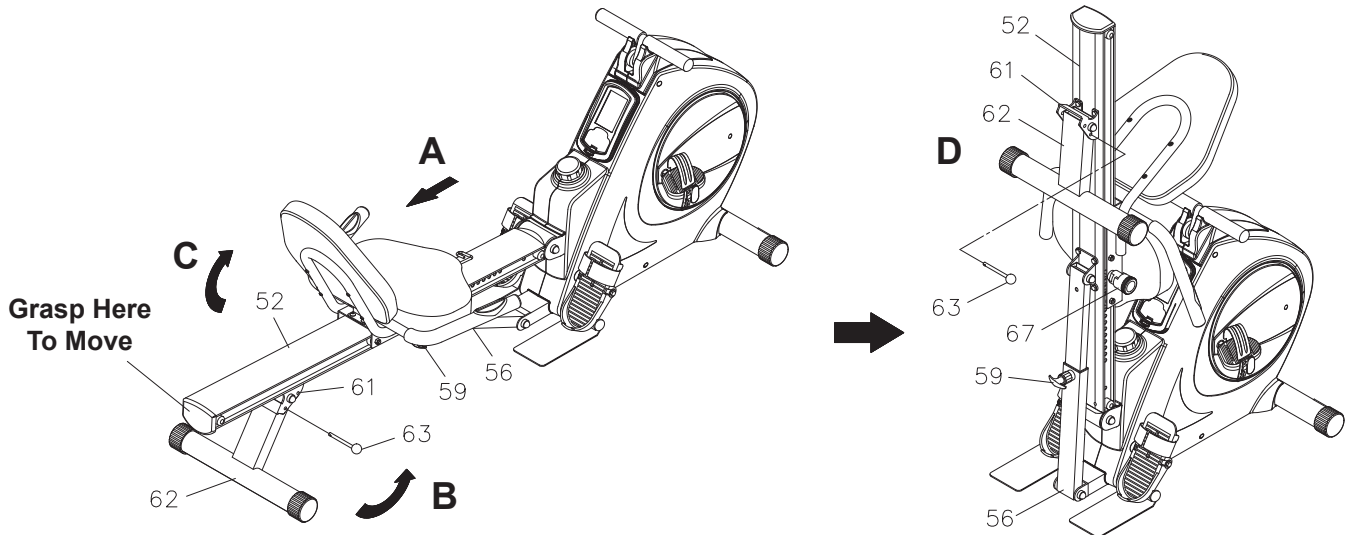

## UNFOLD THE Conversion II® 9003

- a. Pull out the **RELEASE KNOB(59)** and unfold the **RAIL(52)**. Make sure the **RAIL(52)** is locked securely in the unfolded position by **RELEASE KNOB(59)**.
- b. Remove the **PULL PIN(63)** and swing the **REAR SUPPORT(62)** backward, then lock the **REAR SUPPORT(62)** in position with the **PULL PIN(63)**.

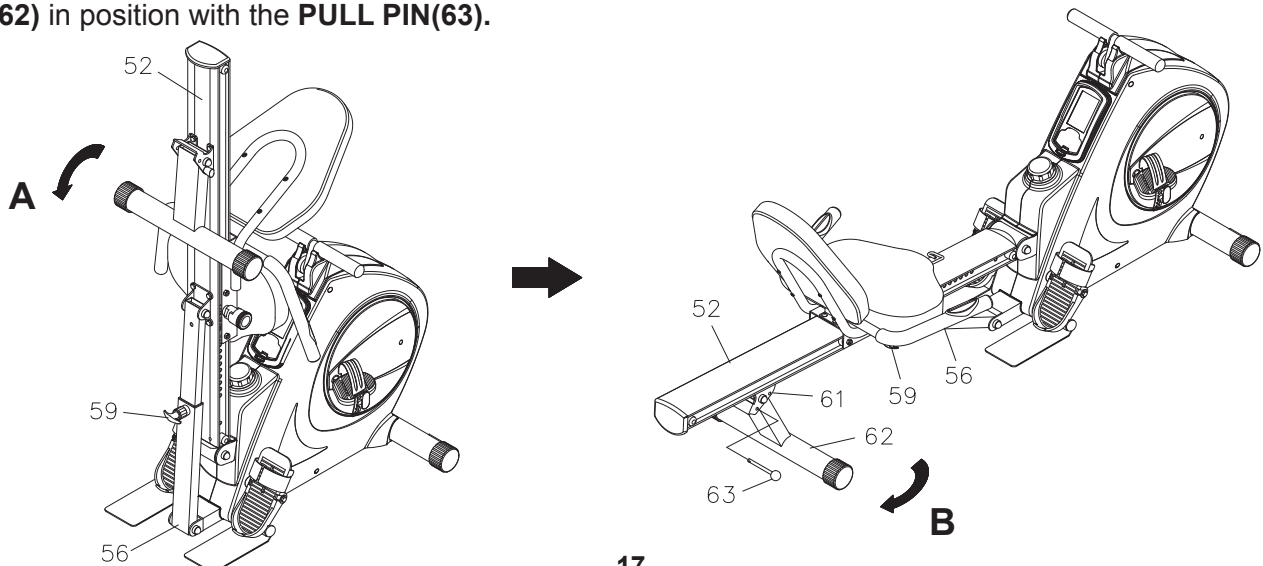

## CONDITIONING GUIDELINES

How you begin your exercise program depends on your physical condition. If you have been inactive for several years or are severely overweight, start slowly and increase your workout time gradually. Increase your workout intensity gradually by monitoring your heart rate while you exercise.

Remember to follow these essentials:

- Have your doctor review your training and diet programs.
- Begin your training program slowly with realistic goals that have been set by you and your physician.
- Warm up before you exercise and cool down after you work out.
- Take your pulse periodically during your workout and strive to stay within a range of 60% (lower intensity) to 90% (higher intensity) of your maximum heart rate zone. Start at the lower intensity, and build up to higher intensity as you become more aerobically fit.
- If you feel dizzy or lightheaded you should slow down or stop exercising.

Initially you may only be able to exercise within your target zone for a few minutes; however, your aerobic capacity will improve over the next six to eight weeks. It is important to pace yourself while you exercise so you don't tire too quickly.

To determine if you are working out at the correct intensity, use a heart rate monitor or use the table below. For effective aerobic exercise, your heart rate should be maintained at a level between 60% and 90% of your maximum heart rate. If just starting an exercise program, work out at the low end of your target heart rate zone. As your aerobic capacity improves, gradually increase the intensity of your workout by increasing your heart rate.

Measure your heart rate periodically during your workout by stopping the exercise but continuing to move your legs or walk around. Place two or three fingers on your wrist and take a six second heartbeat count. Multiply the results by ten to find your heart rate. For example, if your six second heartbeat count is 14, your heart rate is 140 beats per minute. A six second count is used because your heart rate will drop rapidly when you stop exercising. Adjust the intensity of your exercise until your heart rate is at the proper level.

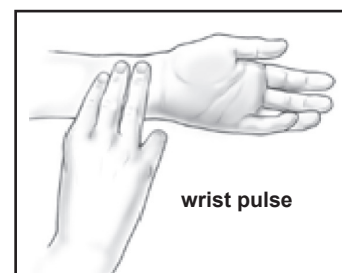

Target Heart Rate Zone Estimated by Age\*

Age	Target Heart Rate Zone (55%-90% of Maximum Heart Rate)	Average Maximum Heart Rate 100%
20 years	110-180 beats per minute	200 beats per minute
25 years	107-175 beats per minute	195 beats per minute
30 years	105-171 beats per minute	190 beats per minute
35 years	102-166 beats per minute	185 beats per minute
40 years	99-162 beats per minute	180 beats per minute
45 years	97-157 beats per minute	175 beats per minute
50 years	94-153 beats per minute	170 beats per minute
55 years	91-148 beats per minute	165 beats per minute
60 years	88-144 beats per minute	160 beats per minute
65 years	85-139 beats per minute	155 beats per minute
70 years	83-135 beats per minute	150 beats per minute

\* For cardiorespiratory training benefits, the American College of Sports Medicine recommends working out within a heart rate range of 55% to 90% of maximum heart rate. To predict the maximum heart rate, the following formula was used:  $220 - \text{Age} = \text{predicted maximum heart rate}$

## WARM-UP and COOL-DOWN

**Warm-Up** The purpose of warming up is to prepare your body for exercise and to minimize injuries. Warm up for two to five minutes before strength training or aerobic exercising. Perform activities that raise your heart rate and warm the working muscles. Activities may include brisk walking, jogging, jumping jacks, jump rope, and running in place

**Stretching** Stretching while your muscles are warm after a proper warm-up and again after your strength or aerobic training session is very important. Muscles stretch more easily at these times because of their elevated temperature, which greatly reduces the risk of injury. Stretches should be held for 15 to 30 seconds. Do not bounce.

### Suggested Stretching Exercises

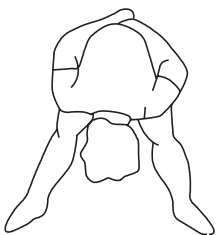

#### Lower Body Stretch

Place feet shoulder-width apart and lean forward. Keep this position for 30 seconds using the body as a natural weight to stretch the backs of the legs. **DO NOT BOUNCE!** When the pull on the back of the legs lessens, gradually try a lower position.

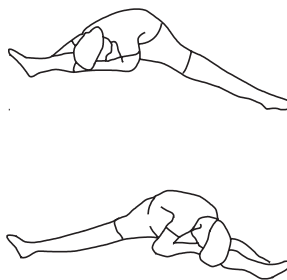

#### Floor Stretch

While sitting on the floor, open the legs as wide as possible. Stretch the upper body toward the knee on the right leg by using your arms to pull your chest to your thighs. Hold this stretch 10 to 30 seconds. **DO NOT BOUNCE!** Do this stretch 10 times. Repeat the stretch with the left leg.

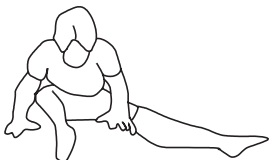

#### Bent Torso Pulls

While sitting on the floor, have legs apart, one leg straight and one knee bent. Pull the chest down to touch the thigh on the leg that is bent, and twist at the waist. Hold this position at least 10 seconds. Repeat 10 times on each side.



#### Bent Over Leg Stretch

Stand with feet shoulder-width apart and lean forward as illustrated. Using the arms, **gently** pull the upper body towards the right leg. Let the head hang down. **DO NOT BOUNCE!** Hold the position a minimum of 10 seconds. Repeat pulling the upper body to the left leg. Do this stretch several times slowly.

**Remember to always check with your physician before starting any exercise program.**

**Cool-Down** The purpose of cooling down is to return the body to its normal, or near normal, resting state at the end of each exercise session. A proper cool-down slowly lowers your heart rate and allows blood to return to the heart. Your cool-down should include the stretches listed above and should be completed after each strength training session.

**PRODUCT PARTS DRAWING**

**FRONT**

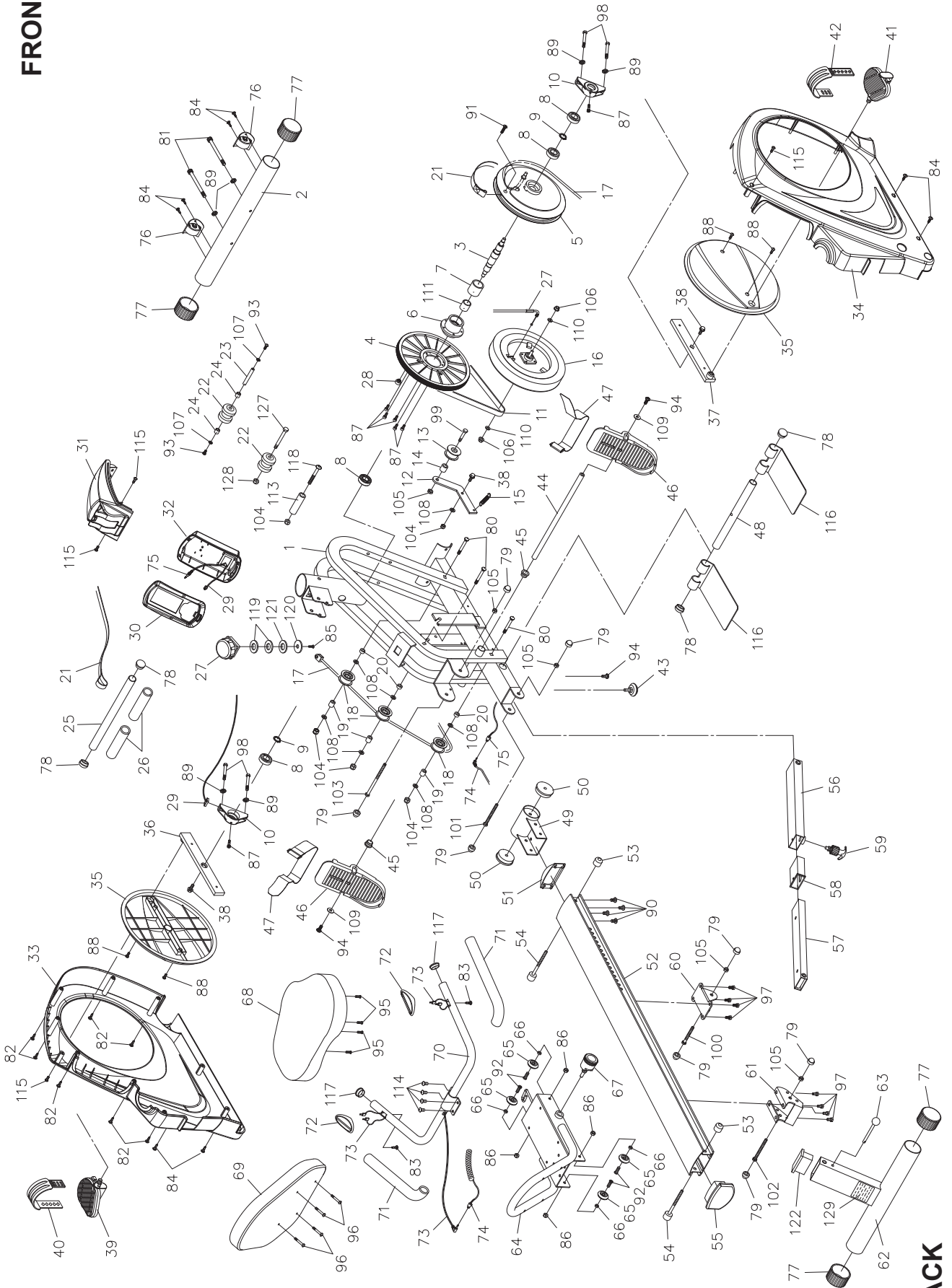

**BACK**

## PARTS LIST

PART#	PART NAME	QTY
1	Main Frame	1
2	Front Stabilizer	1
3	Axle	1
4	Pulley	1
5	Strap Wheel	1
6	Connection Wheel	1
7	One Way Bearing (3520)	1
8	Bearing (6004 zz)	4
9	C Ring (20mm)	2
10	Bearing Housing	2
11	V-Ribbed Belt	1
12	Idler Arm	1
13	Idler Wheel	1
14	Idler Wheel Spacer	1
15	Tension Spring	1
16	Magnetic System	1
17	Bungee Cord	1
18	Bungee Wheel	3
19	Wheel Bushing	3
20	Wheel Spacer	3
21	Strap	1
22	Strap Roller	2
23	Roller Axle	1
24	Roller Spacer	2
25	Handlebar	1
26	Foam Grip	2
27	Tension Knob	1
28	Magnet	1
29	Sensor Wire	1
30	Meter	1
31	Top Cover	1
32	Meter Bottom Cover	1
33	Left Cover	1
34	Right Cover	1
35	Crank Cover	2
36	Left Crank	1
37	Right Crank	1
38	Flange Bolt (M8 x 1.25 x 25mm)	3
39	Left Pedal	1
40	Left Pedal Strap	1
41	Right Pedal	1
42	Right Pedal Strap	1
43	Stand	1
44	Pedal Shaft	1
45	Spacer	2
46	Foot Pedal	2
47	Pedal Strap	2
48	Stopper Tube	1

## PARTS LIST

PART#	PART NAME	QTY
49	Rail Pivot	1
50	Pivot Bushing	2
51	Rail Connection Cap	1
52	Rail	1
53	Stopper	2
54	Stopper Bolt	2
55	Rail Cap	1
56	Support Tube	1
57	Inner Support Tube	1
58	Bushing	1
59	Release Knob	1
60	Support Bracket	1
61	Rear Support Bracket	1
62	Rear Support	1
63	Pull Pin	1
64	Seat Carriage	1
65	Seat Roller	4
66	Seat Roller Spacer (ø8 x ø12 x 6.5mm)	4
67	Spring Pin	1
68	Seat	1
69	Back Cushion	1
70	Handrail	1
71	Foam Grip	2
72	Pulse Sensor Plate	2
73	Pulse Sensor Wire	1
74	Pulse Coil Wire	1
75	Pulse Connection Wire	1
76	Moving Wheel	2
77	Round Endcap (60mm)	4
78	Dome Plug (25mm)	4
79	Nut Cap (M10)	8
80	Carriage Bolt (M8 x 1.25 x 60mm)	3
81	Bolt, Socket Head (M8 x 1.25 x 70mm)	2
82	Screw, Round Head (M4 x 20mm)	7
83	Screw, Round Head (M4 x 25mm)	2
84	Screw, Round Head (M5 x 18mm)	8
85	Screw, Round Head (M5 x 0.8 x 15mm)	1
86	Nylock Nut (M8 x 1.25 x 6.2mm thick)	4
87	Bolt, Socket Head (M5 x 0.8 x 15mm)	7
88	Bolt, Round Head (M6 x 1 x 15mm)	4
89	Lock Washer (M8)	6
90	Bolt, Flat Head (M8 x 1.25 x 16mm)	4
91	Bolt, Flat Head (M8 x 1.25 x 25mm)	1
92	Bolt, Flat Button Head (M8 x 1.25 x 25mm)	4
93	Bolt, Button Head (M6 x 1 x 12mm)	2
94	Bolt, Button Head (M8 x 1.25 x 15mm)	3
95	Bolt, Round Head (M6 x 1 x 15mm)	4
96	Bolt, Round Head (M6 x 1 x 30mm)	4

## PARTS LIST

PART#	PART NAME	QTY
97	Bolt, Hex Head (M8 x 1.25 x 16mm)	8
98	Bolt, Hex Head (M8 x 1.25 x 55mm)	4
99	Bolt, Hex Head (M10 x 1.5 x 45mm)	1
100	Bolt, Hex Head (M10 x 1.5 x 75mm)	1
101	Bolt, Hex Head (M10 x 1.5 x 85mm)	1
102	Bolt, Hex Head (M10 x 1.5 x 95mm)	1
103	Bolt, Hex Head (M10 x 1.5 x 125mm)	1
104	Nylock Nut (M8 x 1.25 x 8mm thick)	5
105	Nylock Nut (M10 x 1.5)	5
106	Flange Nut (M10 x 1.25)	2
107	Washer (M6)	2
108	Washer (M8 x $\varnothing$ 16mm)	7
109	Large Washer (M8 x $\varnothing$ 23mm)	2
110	Washer (M10)	2
111	One Way Bearing (2520)	1
113	Roller Spacer	1
114	Bolt, Button Head (M8 x 1.25 x 12mm)	4
115	Screw, Round Head (M5 x 12mm)	4
116	Foot Plate	2
117	Round Plug (25mm)	2
118	Bolt, Hex Head (M8 x 1.25 x 70mm)	1
119	Large Washer (26 x 38 x 2.0mm thick)	2
120	Large Washer (6 x 32 x 2.0mm thick)	1
121	Large Washer (26 x 34 x 1.0mm thick)	1
122	Rectangular Plug (38mm x 76mm)	1
123	Allen Wrench (6mm)	2
124	Combination Wrench	1
125	Wrench (17mm)	2
126	Manual	1
127	Bolt, Hex Head (M10 x 1.5 x 65mm)	1
128	Thin Nylock Nut (M10 x 1.5)	1
129	Caution Label	1

## LIMITED WARRANTY

MODEL 15-9003B

### WARRANTY

Stamina Products, Inc. warrants that this product will be free from defects in materials and workmanship under normal use, service and proper operation for a period of 90 days on the parts and three years on the frame from the date of the original purchase from an authorized retailer. **THIS WARRANTY SHALL NOT APPLY TO ANY PRODUCT WHICH HAS BEEN SUBJECT TO COMMERCIAL USE, ABUSE, MISUSE, ALTERATION OF ANY TYPE OR CAUSE OR TO ANY DEFECT OR DAMAGE CAUSED BY REPAIR, REPLACEMENT, SUBSTITUTION OR USE WITH PARTS OTHER THAN PARTS PROVIDED BY STAMINA PRODUCTS, INC.** Commercial use includes use of the product in athletic clubs, health clubs, spas, gymnasiums, exercise facilities, and other public or semipublic facilities whether or not the product's use is in furtherance of a profit making enterprise, and all other use which is not for personal, family, or household purposes.

To implement this limited warranty, send a written notice stating your name, date, and place of purchase and a brief description of the defect along with your receipt to **Stamina Products, Inc. P.O. Box 1071, Springfield Missouri, USA, 65801-1071**, or email us at **customerservice@staminaproducts.com**, or call us at **1-800-375-7520**. If the defect is covered under this limited warranty, you will be requested to return the product or part to us for free repair or replacement at our option. **NO ACTION FOR BREACH OF THIS LIMITED WARRANTY MAY BE COMMENCED MORE THAN ONE (1) YEAR AFTER THE DATE THE ALLEGED BREACH WAS OR SHOULD HAVE BEEN DISCOVERED. NO ACTION FOR BREACH OF ANY IMPLIED WARRANTY MAY BE COMMENCED MORE THAN ONE (1) YEAR AFTER DELIVERY OF THE PRODUCT TO THE PURCHASER.** This limited warranty is not transferable. **IF ANY PART OF THE PRODUCT IS NOT IN COMPLIANCE WITH THIS LIMITED WARRANTY OR ANY IMPLIED WARRANTY, THE REMEDY OF REPAIR OR REPLACEMENT IS THE EXCLUSIVE REMEDY AVAILABLE TO YOU.** In the event that the purchaser makes any claim under this limited warranty or any implied warranty, the Warrantor reserves the right to require the product to be returned for inspection, at the purchaser's expense, to the Warrantor's premises in Springfield, Missouri. Return of the enclosed warranty registration card is not required for warranty coverage, but is merely a way of establishing the date and place of purchase.

Stamina Products, Inc. **SHALL NOT BE LIABLE FOR THE LOSS OF USE OF ANY PRODUCT, LOSS OF TIME, INCONVENIENCE, COMMERCIAL LOSS OR ANY OTHER INDIRECT, CONSEQUENTIAL, SPECIAL OR INCIDENTAL DAMAGES DUE TO BREACH OF THE ABOVE WARRANTY OR ANY IMPLIED WARRANTY.**

This limited warranty is the only written or express warranty given by Stamina Products, Inc. This warranty gives you specific legal rights, and you may also have other legal rights which vary from state to state. **ANY OTHER RIGHT WHICH YOU MAY HAVE, INCLUDING ANY IMPLIED WARRANTY OR MERCHANTABILITY OR FITNESS FOR A PARTICULAR PURPOSE, IS LIMITED IN DURATION TO THE DURATION OF THIS WARRANTY.**

The laws in some jurisdictions restrict the rights of manufacturers and distributors of consumer goods to disclaim or limit implied warranties and consequential and incidental damages with respect thereto. If any such law is found to be applicable, the foregoing disclaimers and limitations of and on implied warranties and consequential and incidental damages with respect thereto shall be disregarded and shall be deemed not to have been made to the extent necessary to comply with such legal restriction.



## **NOTES**

## TO CONTACT CUSTOMER SERVICE

For your convenience, Stamina's customer service representatives can be reached by email at customerservice@staminaproducts.com or by phone at 1-800-375-7520 (in the U.S.). Our customer service representatives are available Monday through Thursday from 7:30 a.m. until 5:00 p.m., and Friday 8:00 a.m. until 3 p.m. Central Time.



**ONLINE**  
CUSTOMER SERVICE  
customerservice@staminaproducts.com  
www.staminaproducts.com



**TELEPHONE**  
CUSTOMER SERVICE  
Tel: 1 (800) 375-7520



**FAX**  
CUSTOMER SERVICE  
Fax: (417) 889-8064



**MAIL**  
STAMINA PRODUCTS, INC.  
ATTN: Customer Service  
P.O. Box 1071 Springfield, MO. 65801-1071

Would you like to receive email information or special offers from Stamina Products? Register at [contact.staminaproducts.com](http://contact.staminaproducts.com)

## TO REGISTER YOUR PRODUCT

To enact your warranty, please register your product by going to [register.staminaproducts.com](http://register.staminaproducts.com). Please have your product model number (printed on the cover of this owner's manual) and the serial number (printed on the black and white sticker on your product) ready.

If you don't have internet access, you can call customer service at 1-800-375-7520, or fill out and mail the product registration form below to Stamina Products, Inc.; P.O. Box 1071; Springfield, MO 65801-1071.

<b>PRODUCT REGISTRATION FORM</b>	<b>Stamina Products, Inc.</b> P.O. Box 1071 Springfield, MO 65801-1071
Model Number: .....	Serial Number: .....
Product Name: .....	
Place Purchased: .....	
Date of Purchase: .....	Purchase Price: .....
First Name: .....	Last Name: .....
City: .....	State: ..... Zip Code: .....
Email Address: .....	Phone #: (     ) .....
Would you like to receive email information or special offers from Stamina Products?* <input type="checkbox"/> Yes <input type="checkbox"/> No *If yes, be sure your email address is included above.	



Detach and Mail or Fax the Form Above



## TO ORDER PARTS

If there are missing or damaged parts, you can go to [parts.staminaproducts.com](http://parts.staminaproducts.com) and order those parts. If you have questions, please contact customer service. Do not return the product. To order parts by mail, fill out the sheet below and fax it to 417-889-8064. The part will be mailed to your address.



Detach and Mail or Fax the Form Below



<b>PARTS ORDER FORM</b>	<b>Stamina Products, Inc.</b> P.O. Box 1071 Springfield, MO 65801-1071
Mr./Ms: .....	
Address: ..... Apt. #: .....	
City: ..... State: ..... Zip Code: .....	
<b>IMPORTANT : We must have your phone number to process the order!</b>	
Phone #: (     ) ..... Work Phone #: (     ) .....	
Date of Purchase: .....	
Model #: .....	
Purchased From: .....	

**IMPORTANT : Before filling out the form below make sure you have the correct information.  
Refer to the parts list to make sure you're ordering the right parts!**

PART #	DESCRIPTION	QUANTITY
EXAMPLE: 1	Rear Unit Assembly	1