

4 DC RECYCLE/LAUNDRY CABINET W/DOOR

MODEL: 76423

NEED ASSISTANCE ?

Call 4D CONCEPTS directly for parts or assembly assistance.

Individual stores do not stock parts.

Call our Toll-free number 5 days a week except holidays:

Monday through Friday 8.00am to 5.00pm

Pacific Standard Time

1-888-310-4DCO or 1-888-310 4326

IMPORTANT: Before calling please have the model number
and the packing code number ready for our customer service representatives.

You will find the model number printed on the carton label and the packing
code printed in black ink on the side of the carton.

Model 76423 Packing code

It is important that you retain the model number and the packing code
along with the original receipt of purchase for future reference.

Made in China

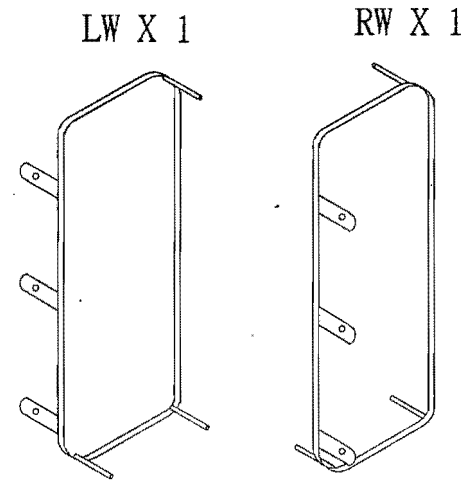
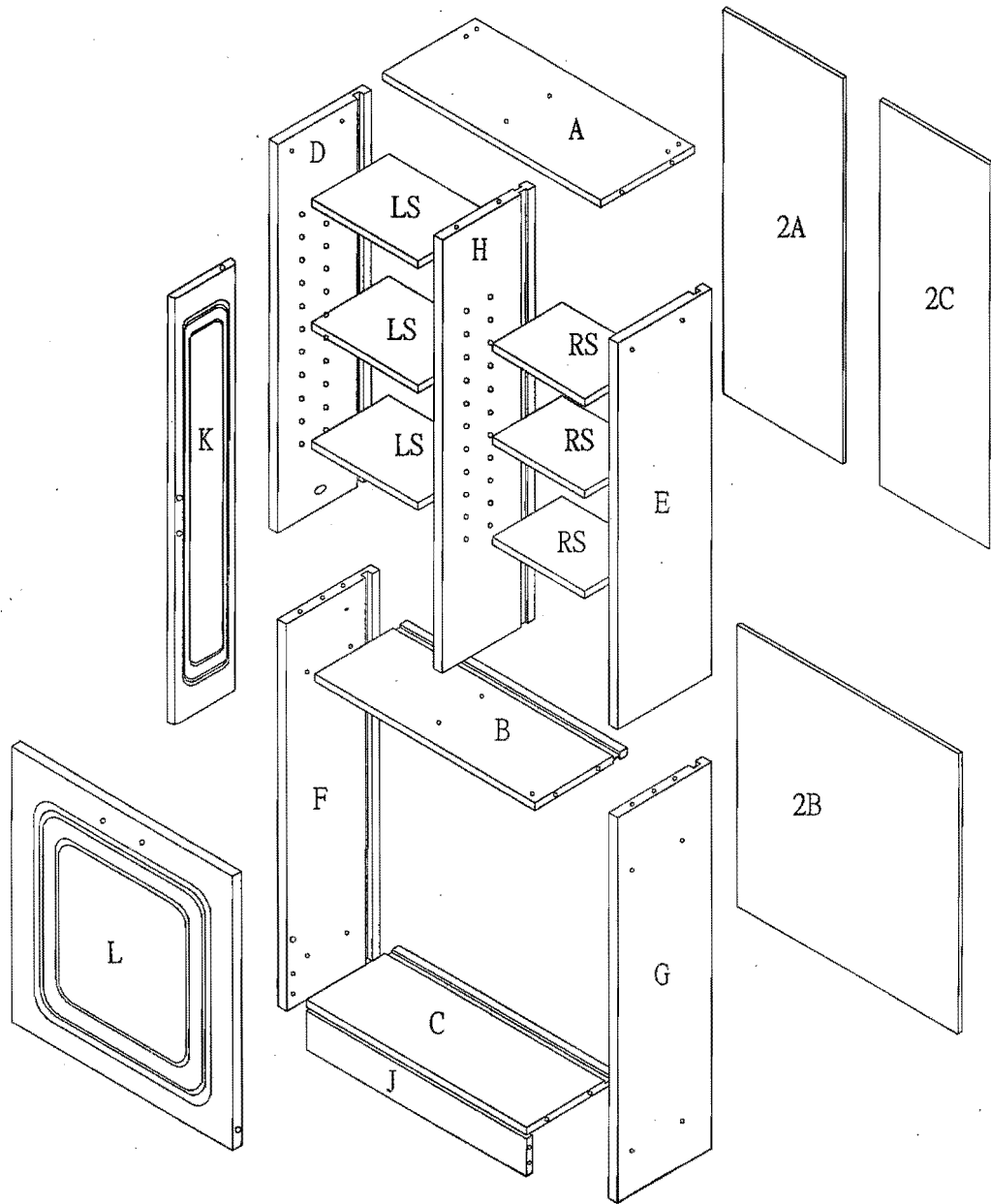

2Y X 1

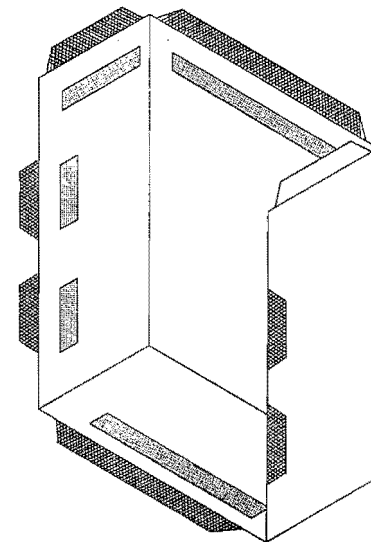

76423 ASSEMBLY INSTRUCTION

M X 8
6 X 30 mm



N X 16
8 X 38 mm

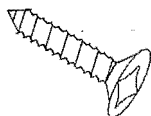

P X 24



2V X 2

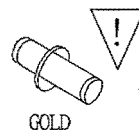

2R X 1



Q X 1

(FIXED DOOR HINGE)



R X 1

(SPRUNG DOOR HINGE)



2K X 1
GLUE

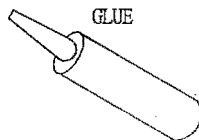

U X 2



2S X 4
3 X 12 mm



S X 2

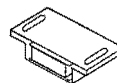

2T X 2
3 X 10 mm



T X 2

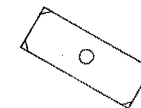

3U X 2
3.5 X 10 mm



2Z X 12

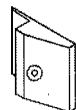

3Z X 12
3 X 14 mm



V X 4
4 X 25 mm



W X 2



Y X 2

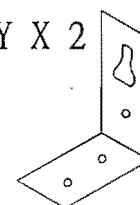

Z X 4
4 X 10 mm



1Z X 6
4 X 14 mm



2U X 2

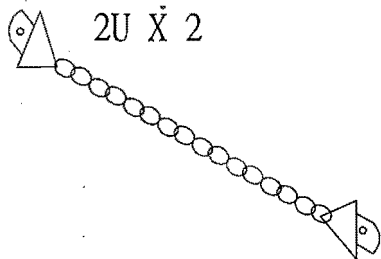

2W X 3

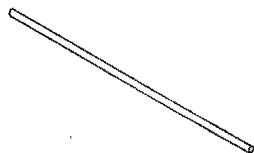

2M X 2

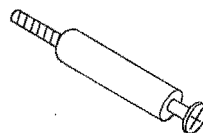

2N X 2



2P X 4
4 X 32 mm



2Q X 4
5.5 X 26 mm



Sticker X 12



STEP 1

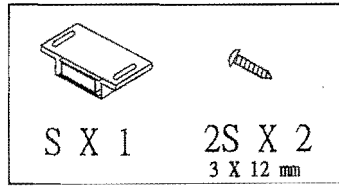
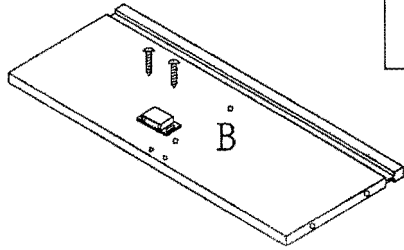

STEP 2

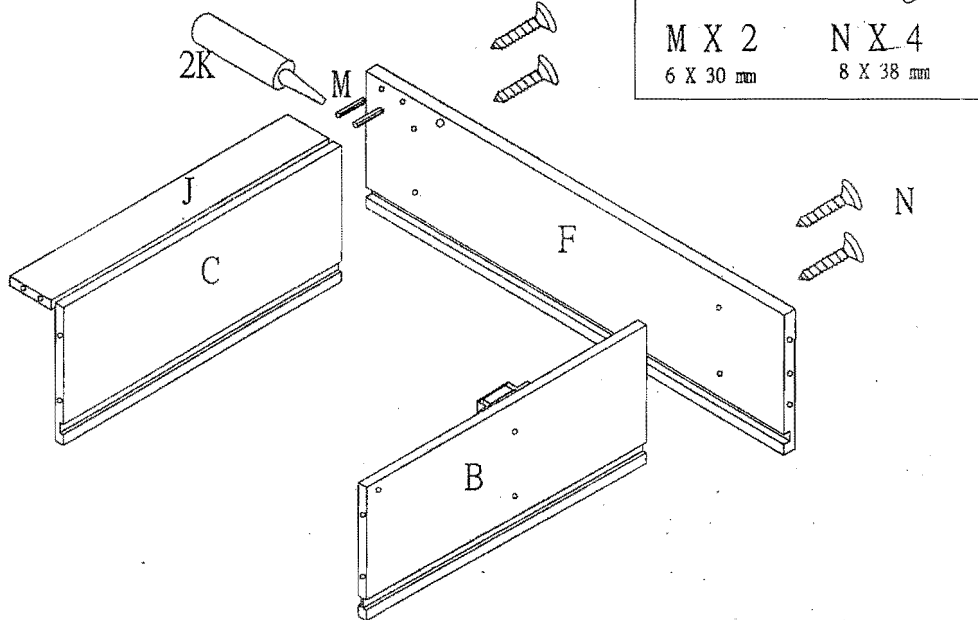

STEP 3

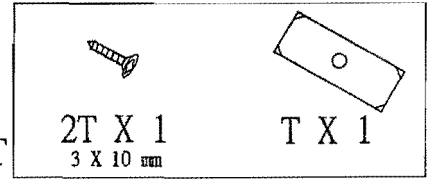
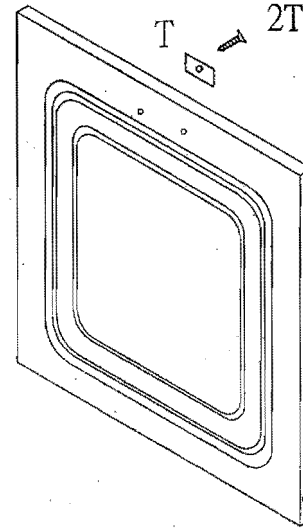

STEP 4

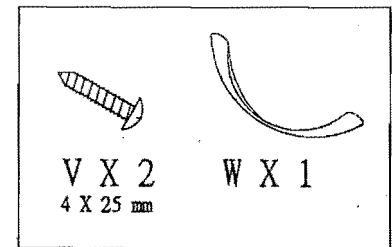
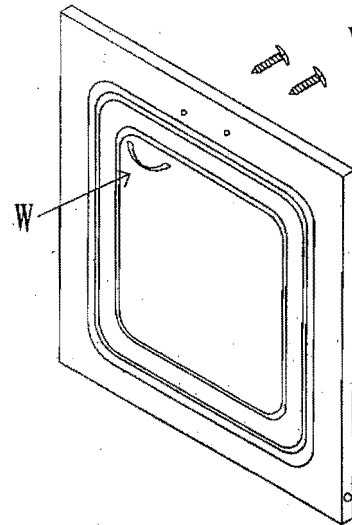

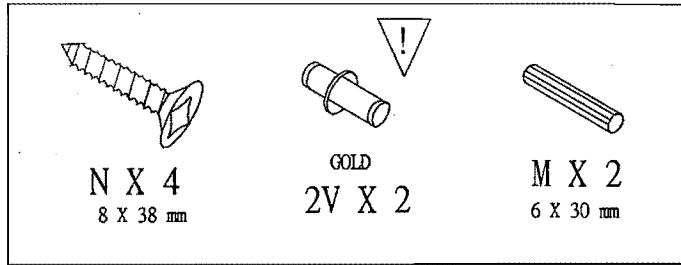

STEP 5

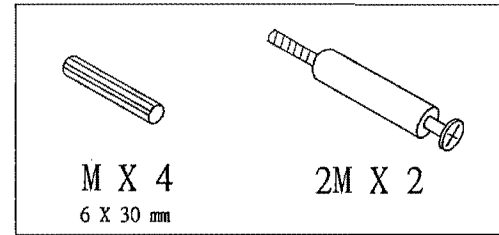
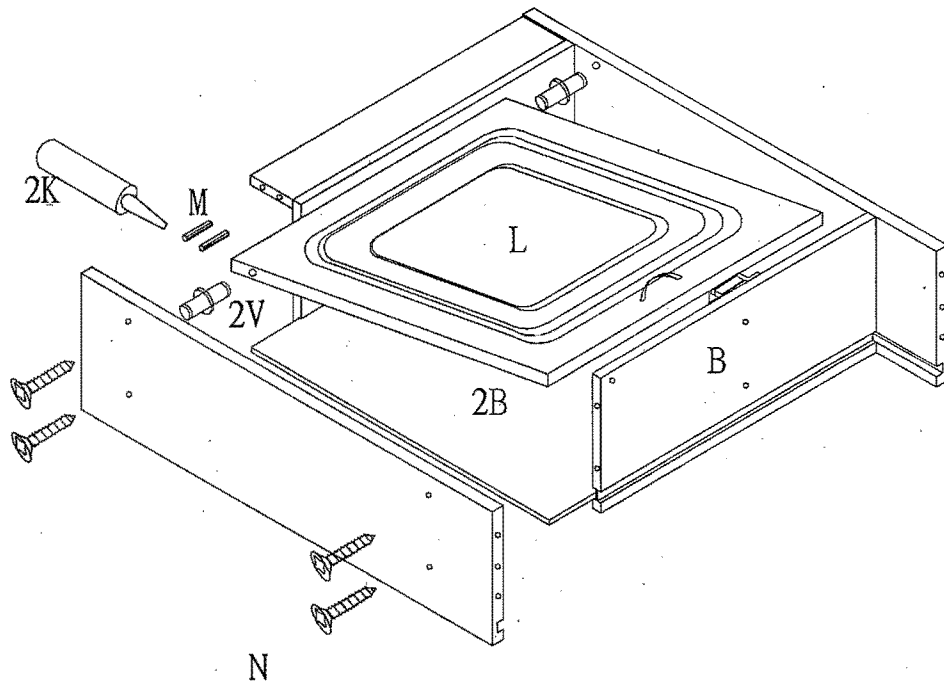

STEP 6

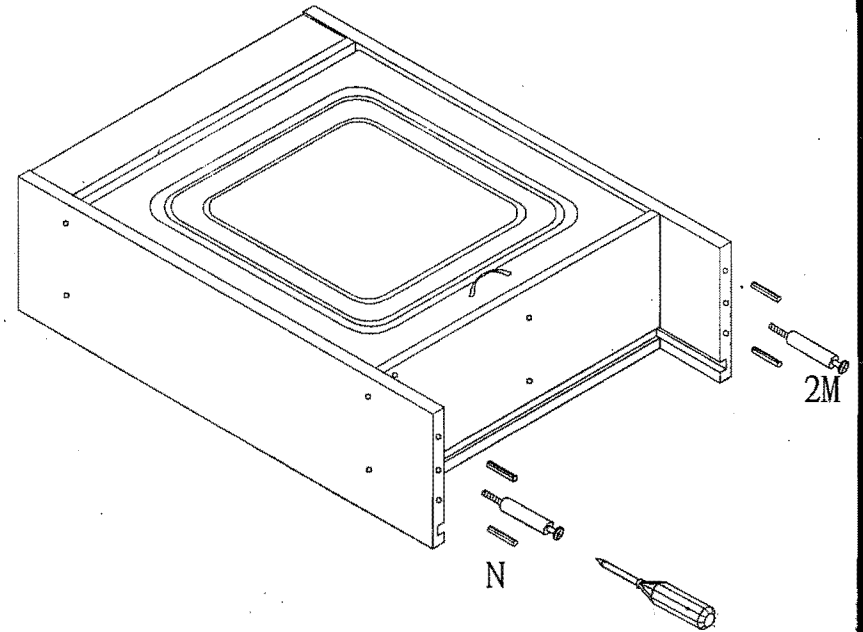

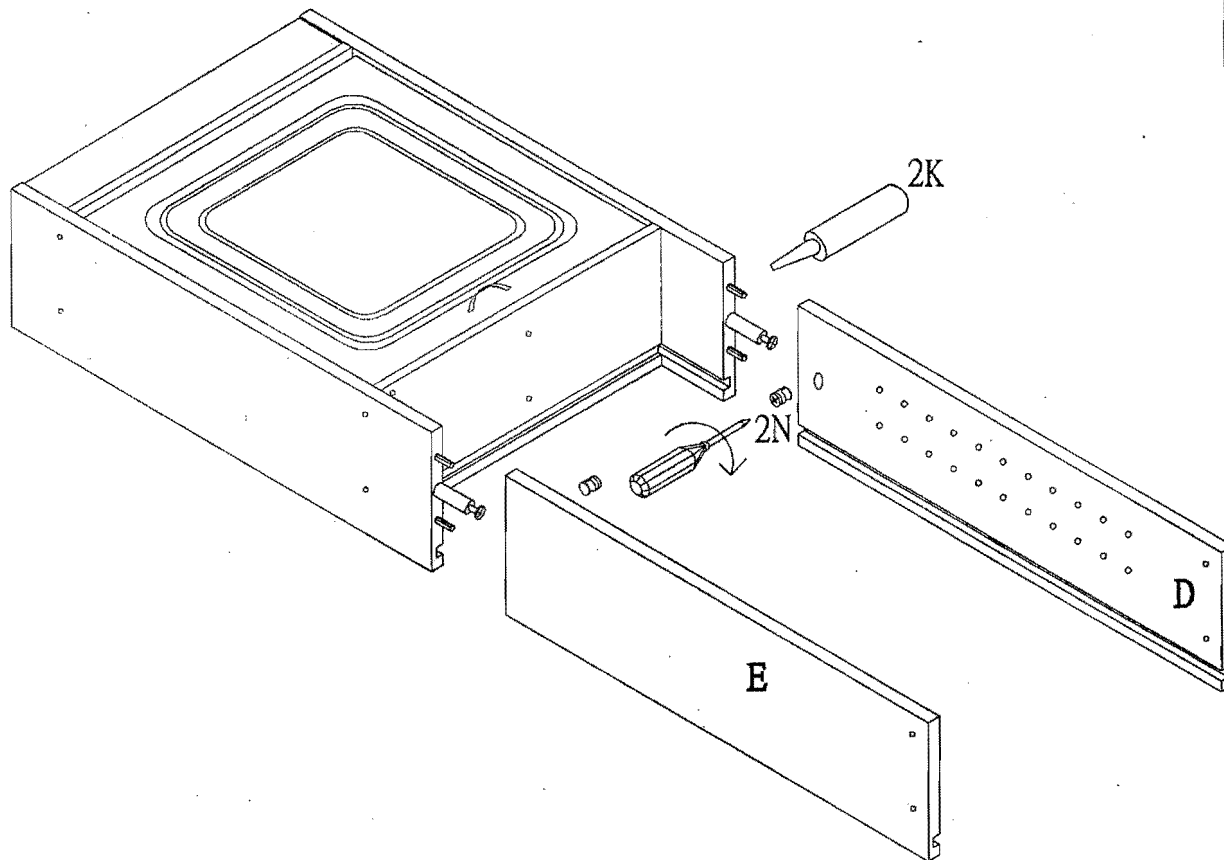
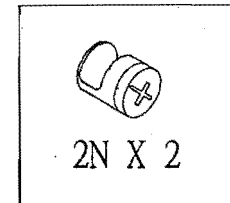

STEP 7

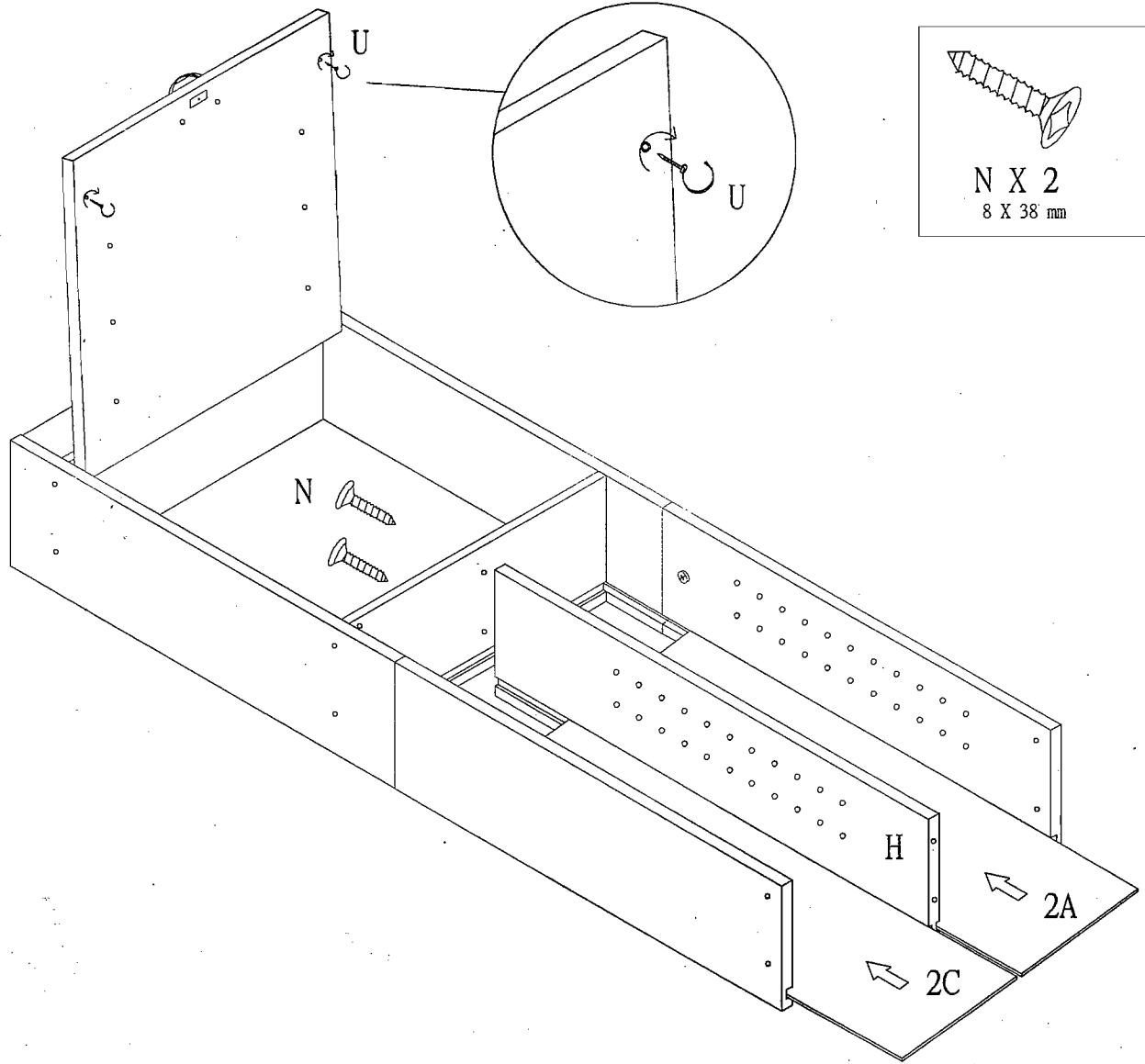

STEP 8

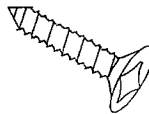

	
N X 2 8 X 38 mm	U X 2

STEP 9

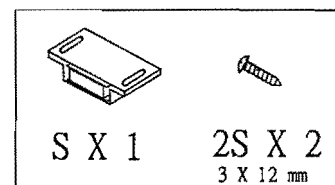
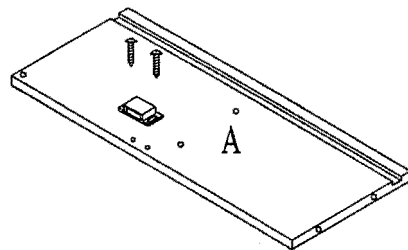

STEP 10

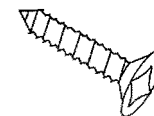
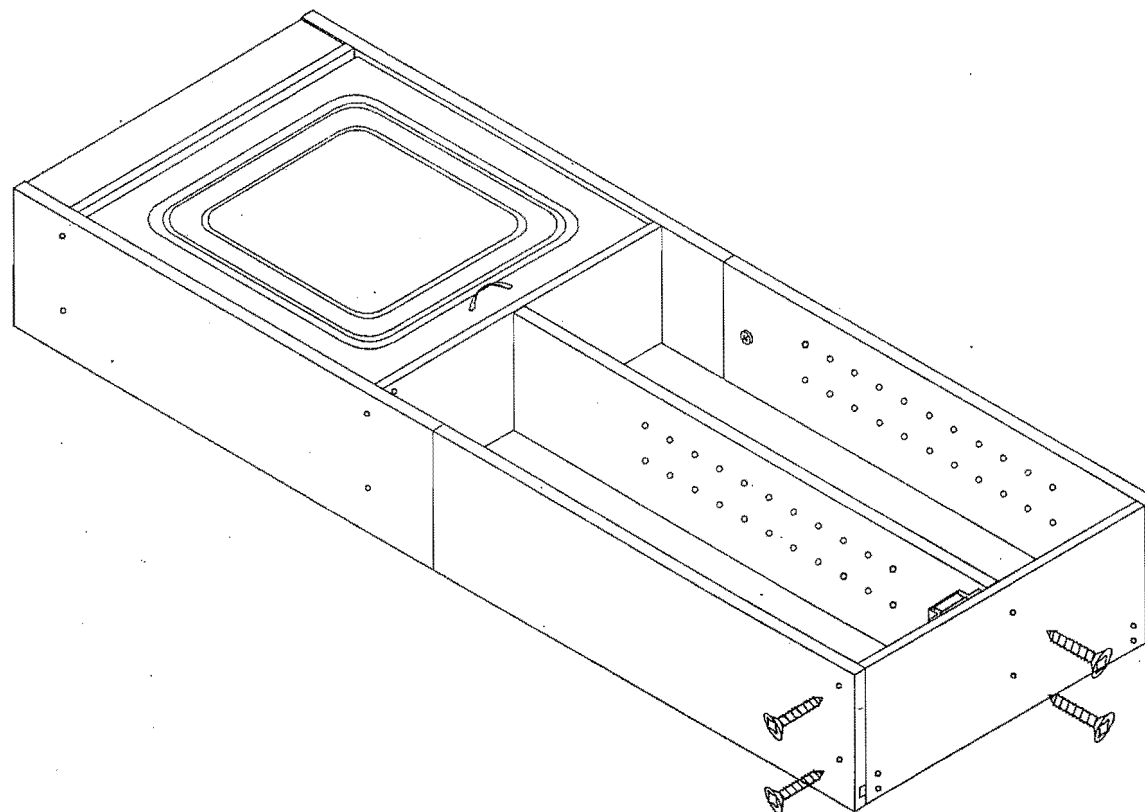

N X 6
8 X 38 mm



N

STEP 11

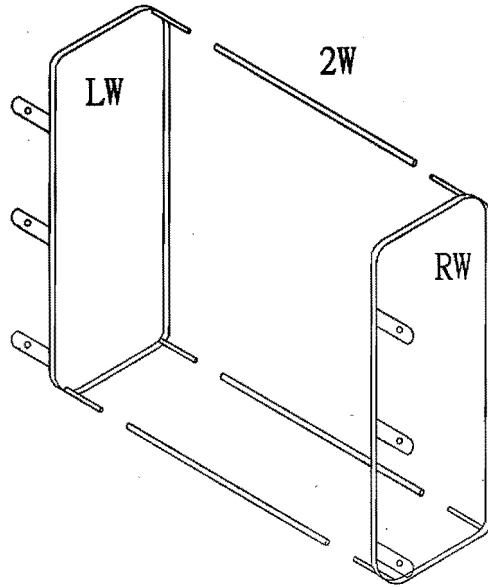

STEP 13

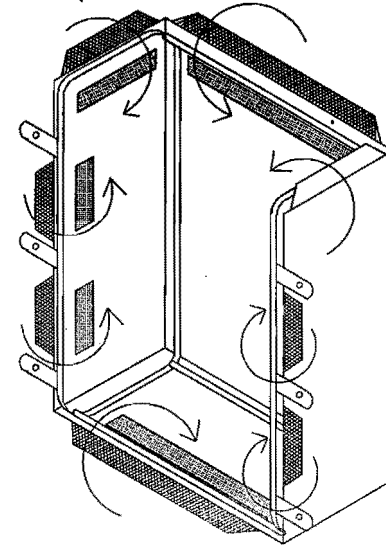

STEP 12

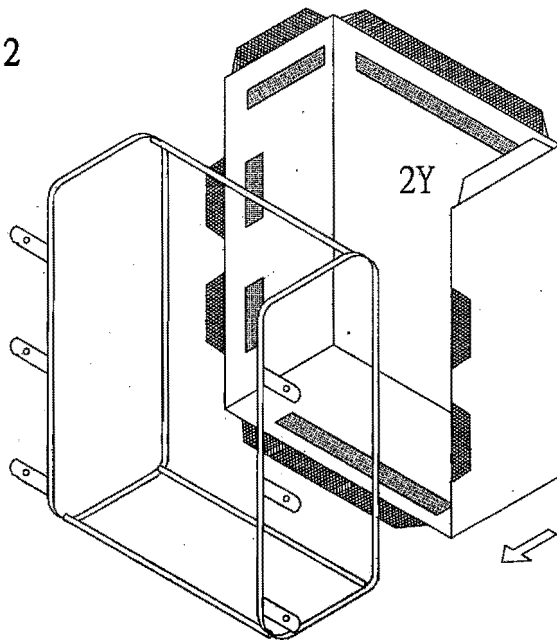

STEP 14

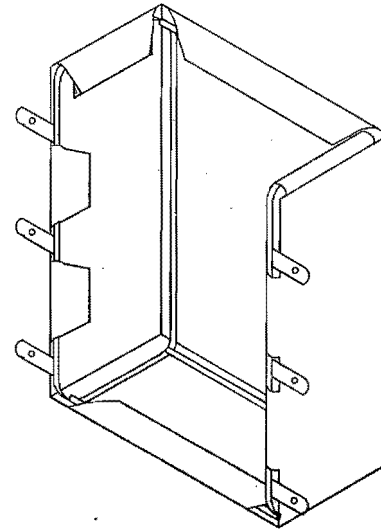

STEP 15

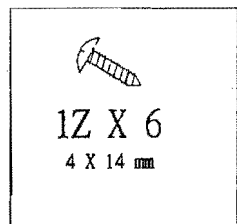

WITH TWO PEOPLE
STAND UP THE
UNIT CAREFULLY
AND PUT INTO
PLACE !

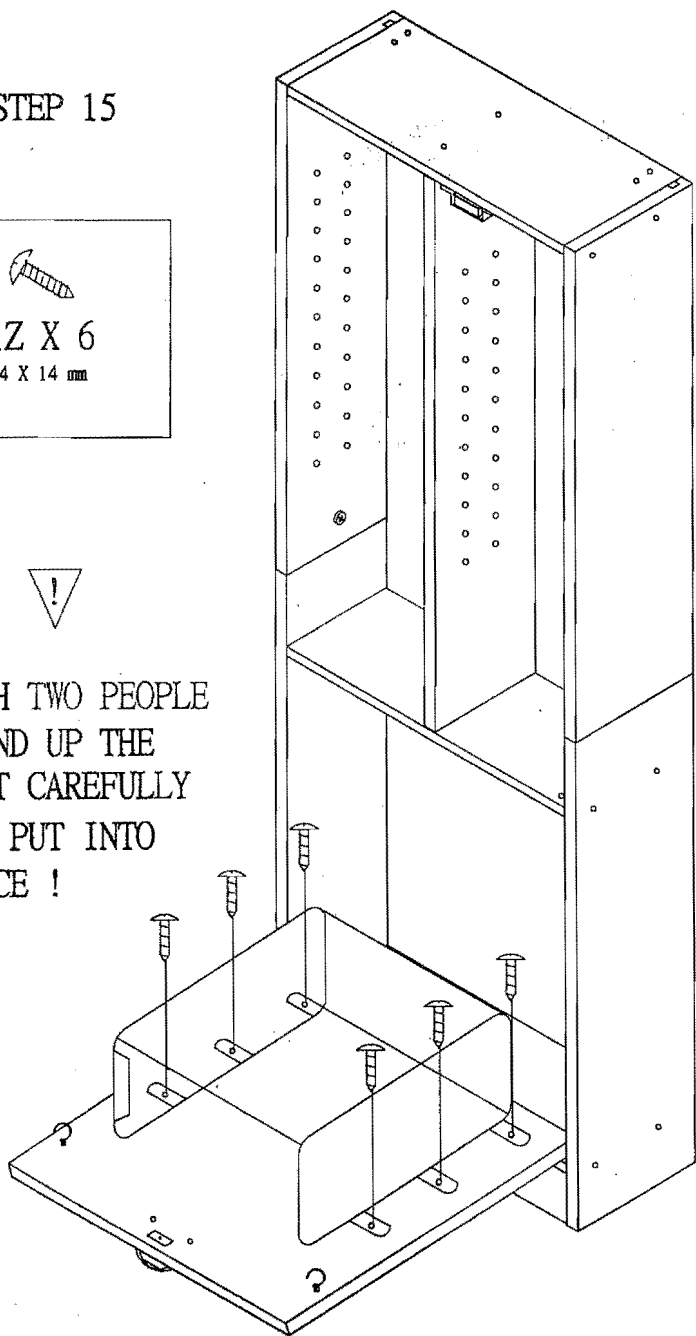

STEP 16

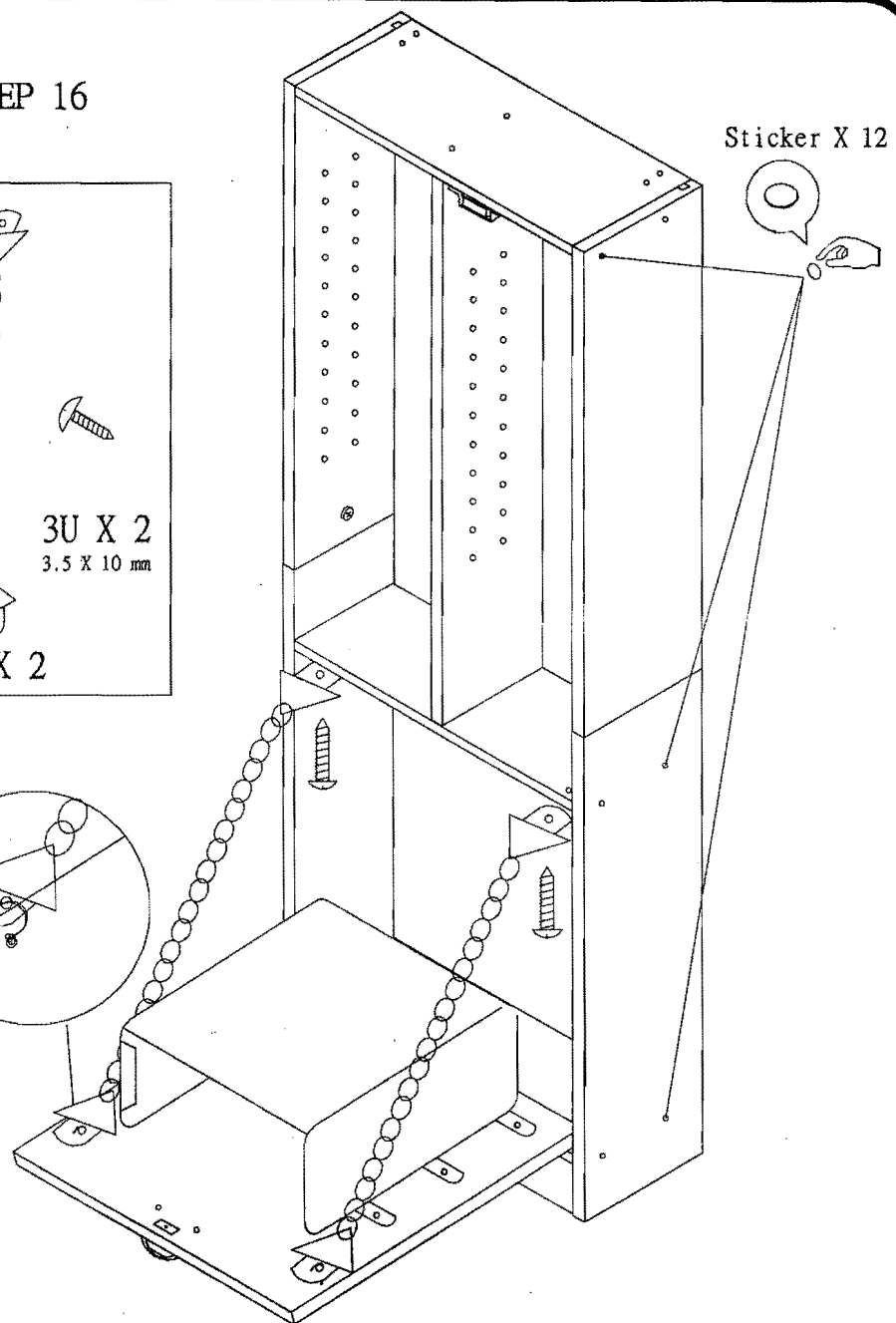
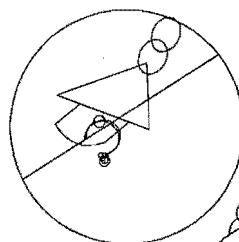
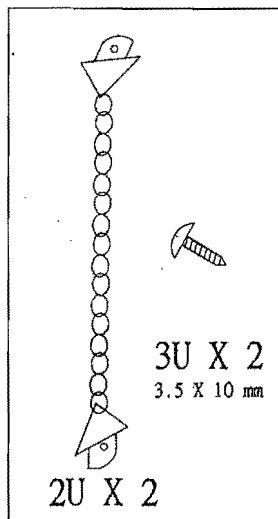

STEP 17

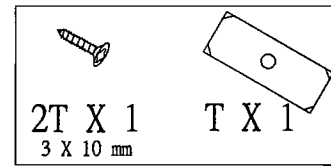
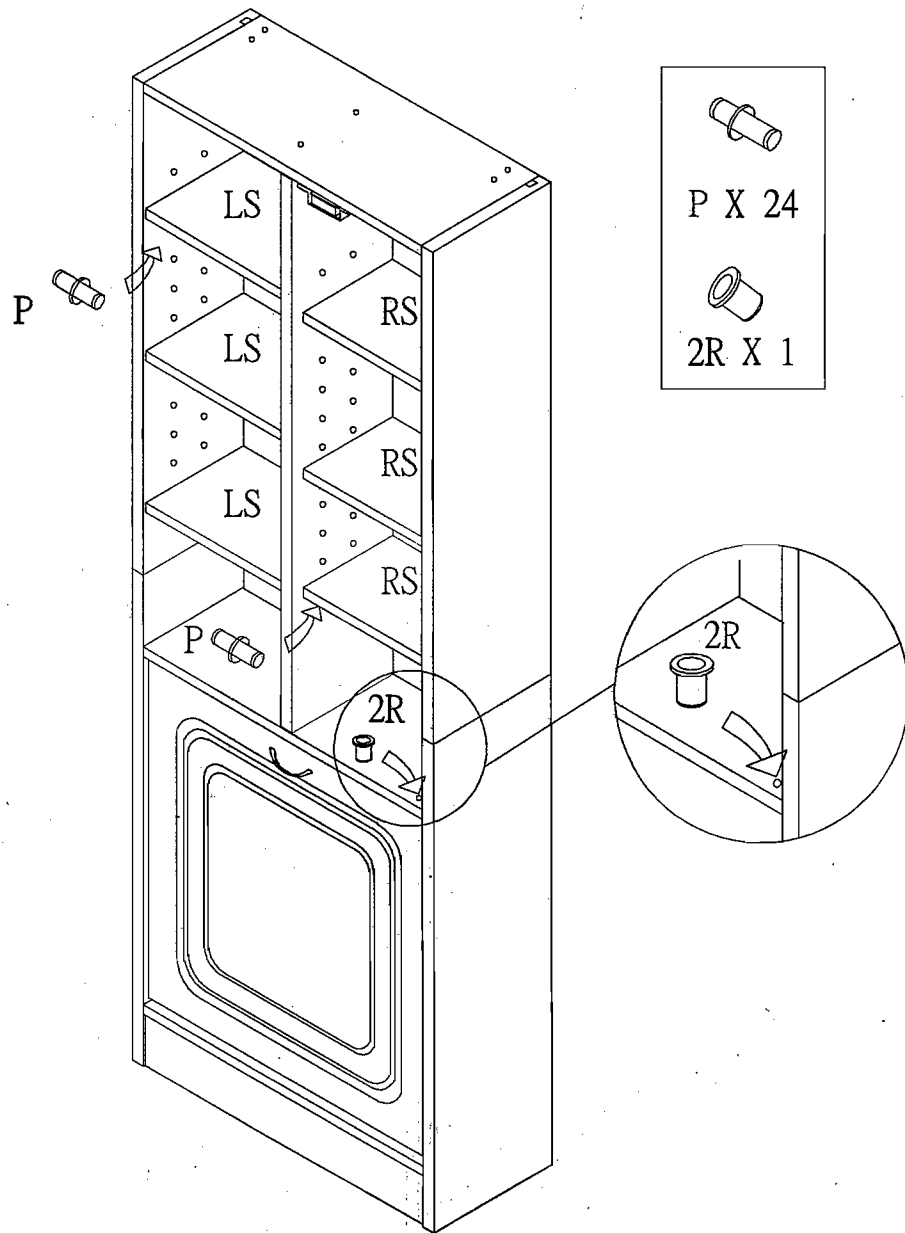

STEP 18

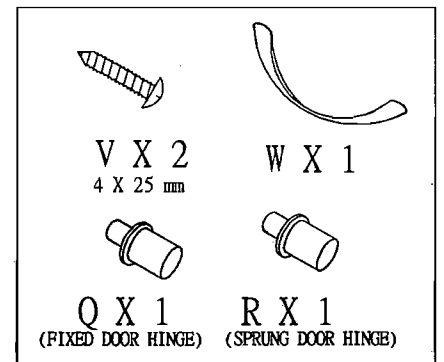
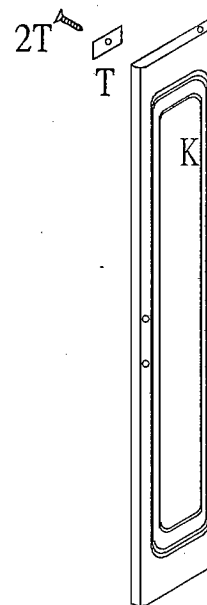

STEP 19

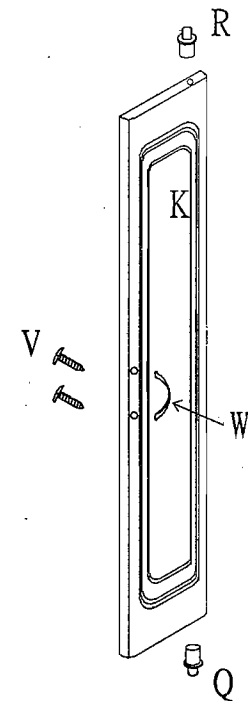

STEP 20

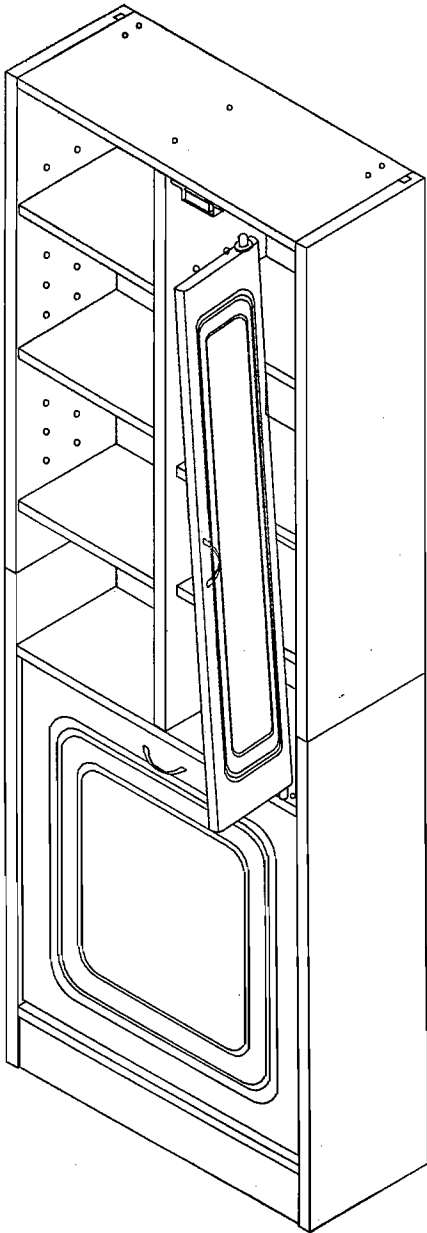

STEP 21

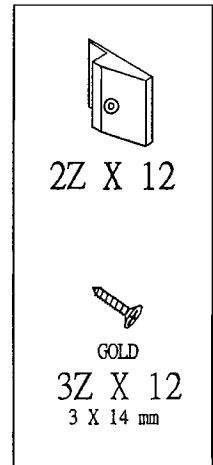
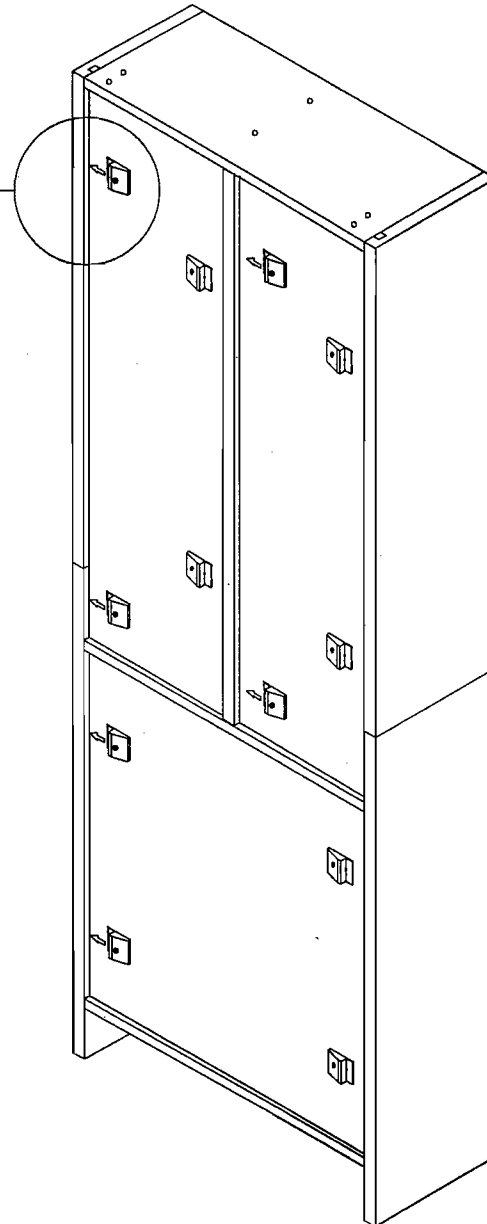
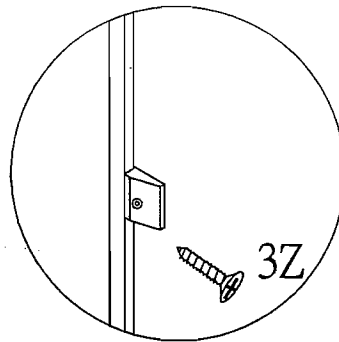
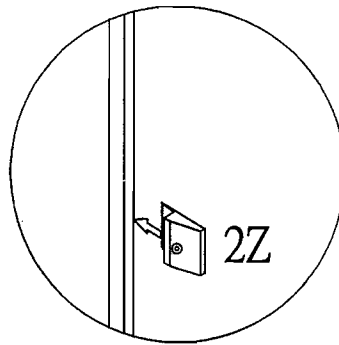

STEP 23

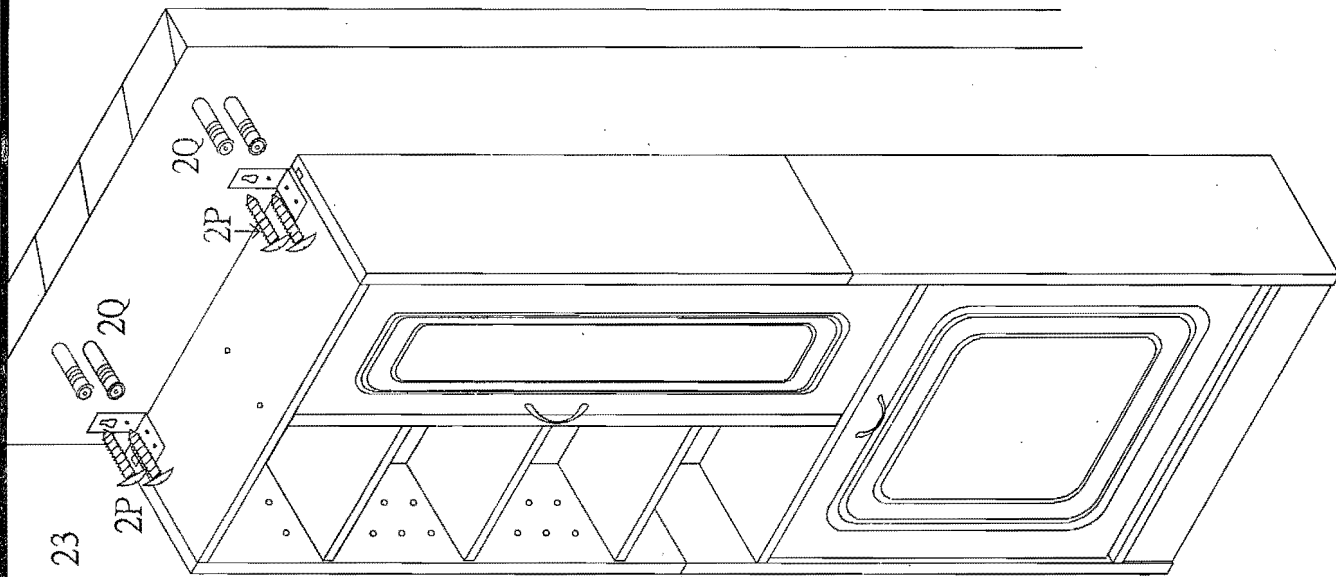
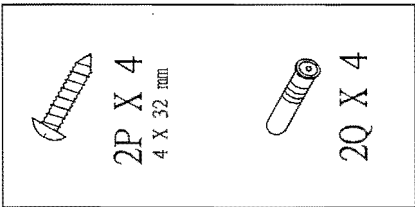

STEP 22

