

OWNER'S MANUAL
RETAIN FOR FUTURE REFERENCE

MODEL NUMBER **98107**
SERIAL NUMBER



USER'S WEIGHT LIMITATION 250lbs.

- ASSEMBLY
- OPERATING INSTRUCTIONS
- WARRANTY

DISTRIBUTED BY
PHOENIX
HEALTH & FITNESS INC.™

DUAL ACTION MINI STEPPER

Warranty Coverage: Phoenix Health and Fitness, Inc. ("Phoenix Health and Fitness") warrants to the original purchaser that each new product to be free from defects in workmanship and material, under normal use and conditions.

Period of Coverage: The Warranty on this product runs for a period of NINETY (90) days from the date of your purchase and includes all parts and materials.

It is recommended that the Original Receipt be kept with the product manual.

Remedy Provided by Phoenix Health and Fitness: Phoenix Health and Fitness will provide a replacement part free of charge if a defect is found during the Warranty period. You must pay any charges for shipping and handling outside of the Continental United States and for labor. You may select any reputable service center to install any replacement part.

Parts repaired or replaced pursuant to this Warranty shall be warranted for the unexpired portion of the Warranty applying to the original product. Any technical advice furnished before or after delivery in regard to the use or application of Phoenix Health and Fitness products is furnished without charge and on the basis that it represents Phoenix Health and Fitness' best judgment under the circumstances but that the advice is used at your sole risk.

Procedure for Obtaining Your Remedy Under This Warranty: In the event you discover a defect in this product, please phone our Customer Service Department at 1 (888) 535.8637 between the hours of 8:00 a.m. and 4:00 p.m. (Pacific Standard Time). You may order your free replacement part at that time, and you may obtain assistance from our Customer Service professionals. Parts will be shipped to you within one hundred eighty (180) days of your notification to our Customer Service Department of your Warranty claim. To help us assist you, please have the following information ready:

- Model name or number from the cover of the manual;
- Serial number located on the frame of the unit; and
- The part description and the order number.

Limitations on Warranty: This Warranty does not apply to you if you have purchased this product for resale. This Warranty does not cover any problems, damages or failures that are caused by accident, improper assembly, failure to observe cautionary labels on the product, failure to operate the product correctly, abuse or freight damage. Phoenix Health and Fitness does not warrant against any damage or defects that may result from repair or alterations made to the product by a repair facility.

This Warranty shall terminate if you sell or otherwise transfer this product. This Warranty does not apply to any product shipped or handled outside of the United States. This Warranty does not apply if the product is used for rental or commercial use.

Consequential and incidental damages are not recoverable under this Warranty.

(Some states do not allow the exclusion or limitation of incidental or consequential damages, so the above limitation or exclusion may not apply to you.)

THIS WARRANTY IS EXPRESSLY IN LIEU OF ALL OTHER EXPRESS WARRANTIES. ALL IMPLIED WARRANTIES, INCLUDING WARRANTIES OF MERCHANTABILITY OR FITNESS FOR ANY PARTICULAR PURPOSE, ARE LIMITED IN DURATION TO ONE (1) YEAR FROM THE EFFECTIVE DATE OF THIS WARRANTY. PHOENIX HEALTH AND FITNESS IS NOT LIABLE FOR CONSEQUENTIAL OR INCIDENTAL DAMAGES RESULTING FROM ANY DEFECT IN PARTS NOR FOR ANY BREACH OF EXPRESS OR IMPLIED WARRANTIES. PHOENIX HEALTH AND FITNESS' SOLE LIABILITY UNDER THIS WARRANTY IS LIMITED TO THE TERMS DESCRIBED IN THIS FORM.

THIS WARRANTY GIVES YOU SPECIFIC LEGAL RIGHTS, AND YOU MAY ALSO HAVE OTHER RIGHTS WHICH VARY FROM STATE TO STATE.

Warning

Before using this product, please consult your personal physician for a complete physical examination. Frequent and strenuous exercise should be approved by your doctor. If any discomfort should result from your use of this product, stop exercising and consult your doctor. Proper usage of this product is essential. Please read your manual carefully before exercising.

Please keep all children away from the equipment during use and when equipment is unattended.

Always wear appropriate clothing, including athletic shoes, when exercising. Do not wear loose clothing that could become caught during exercising.

Make sure that all bolts and nuts are tightened when equipment is in use. Periodic maintenance is required on all exercise equipment to keep it in good condition.

Before beginning

How you begin your exercise program depends on your physical condition. If you have been inactive for several years, or are severely overweight, you must start slowly and increase your time gradually, a few minutes per week.

Initially you may be able to exercise only for a few minutes in your target zone. However, your aerobic fitness will improve over the next six to eight weeks. Don't be discouraged if it takes longer. It's important to work at your own pace. Ultimately, you'll be able to exercise continuously for 30 minutes. And the better your aerobic fitness, the harder you will have to work to stay in your target zone. But remember these essentials:

>Contact your physician before starting a workout or training program. Have your doctor review your training and diet programs to advise you of a workout routine you should adopt.

>Begin your training program slowly with realistic goals that have been set by you and your doctor.

>Supplement your program with some type of aerobic exercise such as walking, jogging, swimming, dancing and/or bicycling.

>Monitor your pulse frequently. If you do not have an electronic heart rate monitor, have your physician show you the proper way to manually check your pulse by using your wrist or neck. Establish your target heart rate based on your age and condition.

>Drink plenty of fluids during the course of your routine. You must replace the water content lost from excessive exercising to avoid dehydration. Avoid drinking large amounts of cold liquids. Fluids should be at room temperature when consumed.



The Surgeon General
has determined that lack
of physical activity is
detrimental to your health.

STEP 1

Insert the Computer Wire(17) into the bottom of the Computer(15). Then insert the Computer(15) onto the Computer Holder(16) as shown.

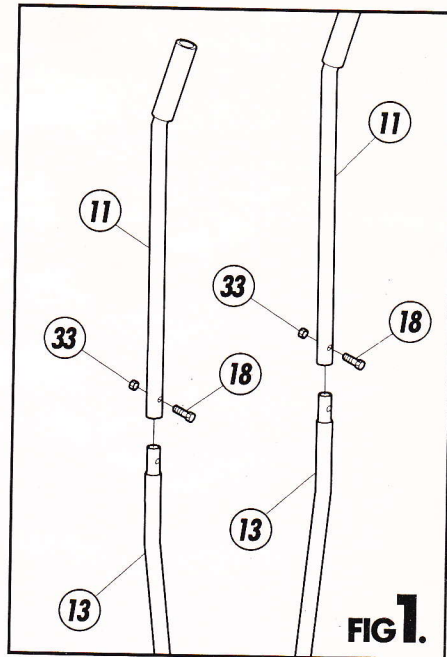
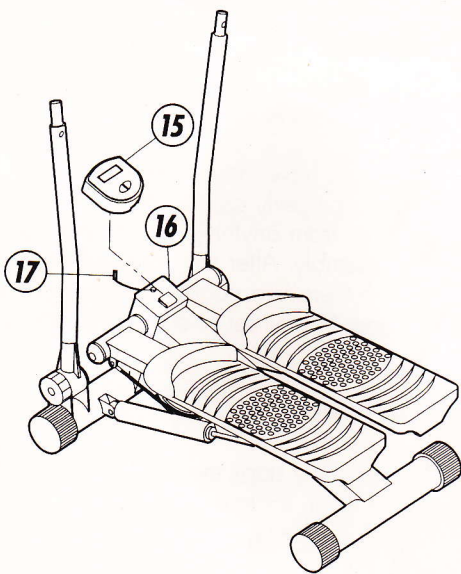

STEP 2

Attach the Center Handlebars(13) to the Lower Handlebars(12) and secure with Bolts(18) and Nuts(33).

Attach the Upper Handlebars(11) to the Center Handlebars(13) and secure with Bolts(18) and Nuts(33) as shown in FIG 1.

Your Dual Action Mini Stepper is now fully assembled.

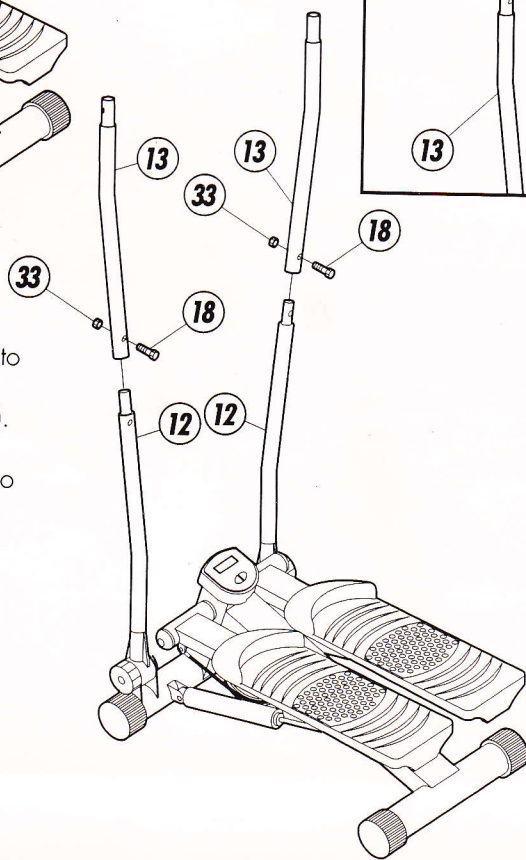

IMPORTANT STEPS

Operating Instructions

Before you exercise, adjust the Tension Knob(19) to assure that both Pedals(2) are in the proper position, also make sure the Cable(23) is in the valley of the Pulley(22) as shown in FIG 2.

Electronic Instructions

FUNCTIONAL BUTTONS:

Reset: To reset the Timer, Distance, Count, and Calories to zero and to restart.

Select: To select or scan the different functions.

FUNCTIONS:

1. Time: Displays the time in which you have exercised.
2. Distance: Converts the number of steps into distance traveled (miles).
3. Count: Displays the number of steps performed during a workout session.
4. Total Count: Displays the total number of steps taken.
5. Calories: Displays the estimated number of calories burned during a workout session.

NOTE:

The power will automatically turn off after 5 minutes without any movement on the machine.

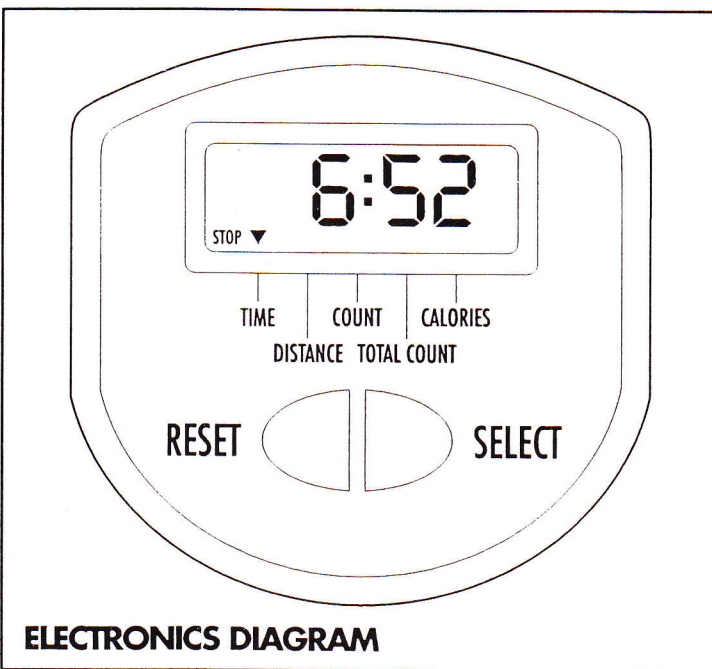
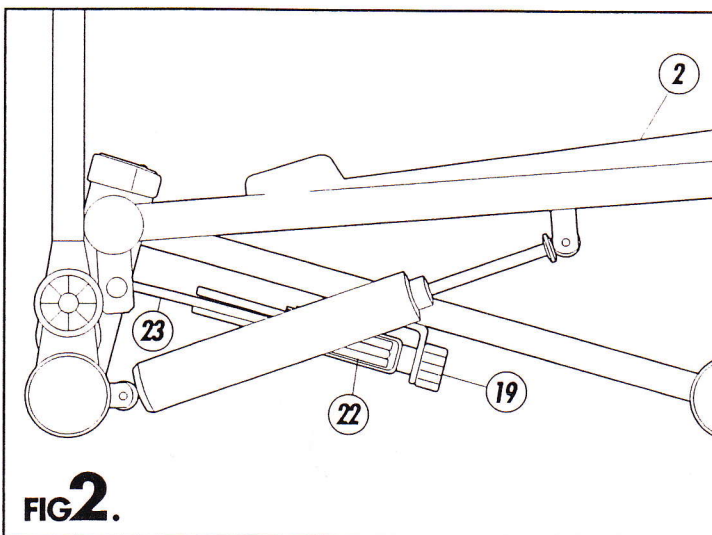

COMPARISON CHART

For your convenience, we have identified the hardware used in the assembly of this product. This chart is provided to help you identify those items that may be unfamiliar to you. All of the hardware here is shown at full size.

18
Bolt
M6 x 30mm
(4 pieces)

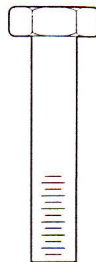

33
Nut
M6mm
(4 pieces)



A MAJORITY OF THE LISTED HARDWARE IS ALREADY IN PLACE

NUMBER	DESCRIPTION	QUANTITY	ORDER NUMBER
1	Main Frame	1	107L-01
2	Pedal	2	107L-02
3	Right Pedal Arm	1	107L-03
4	Left Pedal Arm	1	107L-04
5	Foot Cap	4	107L-05
6	Shock	2	107L-06
7	Adjustment Knob	2	107L-07
8	Arm Housing	2	107L-08
9	10 x 32mm Washer	2	107L-09
10	Grip	2	107L-10
11	Upper Handlebar	2	107L-11
12	Lower Handlebar	2	107L-12
13	Center Handlebar	2	107L-13
14	10 x 22mm Washer	1	107L-14
15	Computer	1	107L-15
16	Computer Holder	1	107L-16
17	Computer Wire	1	107L-17
18	M6 x 30mm Bolt	4	107L-18
19	Tension Knob	1	107L-19
20	Sensor	1	107L-20
21	M4 x 12 Flat Head Screw	4	107L-21
22	Pulley	1	107L-22
23	Cable	1	107L-23
24	Metal Spacer	1	107L-24
25	Plastic Spacer	1	107L-25
26	Mounting Bracket	1	107L-26
27	M8 x 40mm Bolt	1	107L-27
28	M8 Nut	1	107L-28
29	M8 x 12mm Socket Bolt	2	107L-29
30	Bushing	4	107L-30
31	Round Endcap	2	107L-31
32	Bumper	2	107L-32
33	M6mm Nut	4	107L-33
34	M8 x 40mm Bolt	4	107L-34
35	M8 x 66mm Carriage Bolt	2	107L-35
36	M8mm Nut	4	107L-36
37	Brake Pad	4	107L-37
38	Pedal Screw	4	107L-38

NOTE: #18 Bolt (4 pieces) and #33 Nut (4 pieces) are packed in the hardware kit.

parts diagram

MANY PARTS SHOWN HAVE BEEN PRE-ASSEMBLED BY THE FACTORY

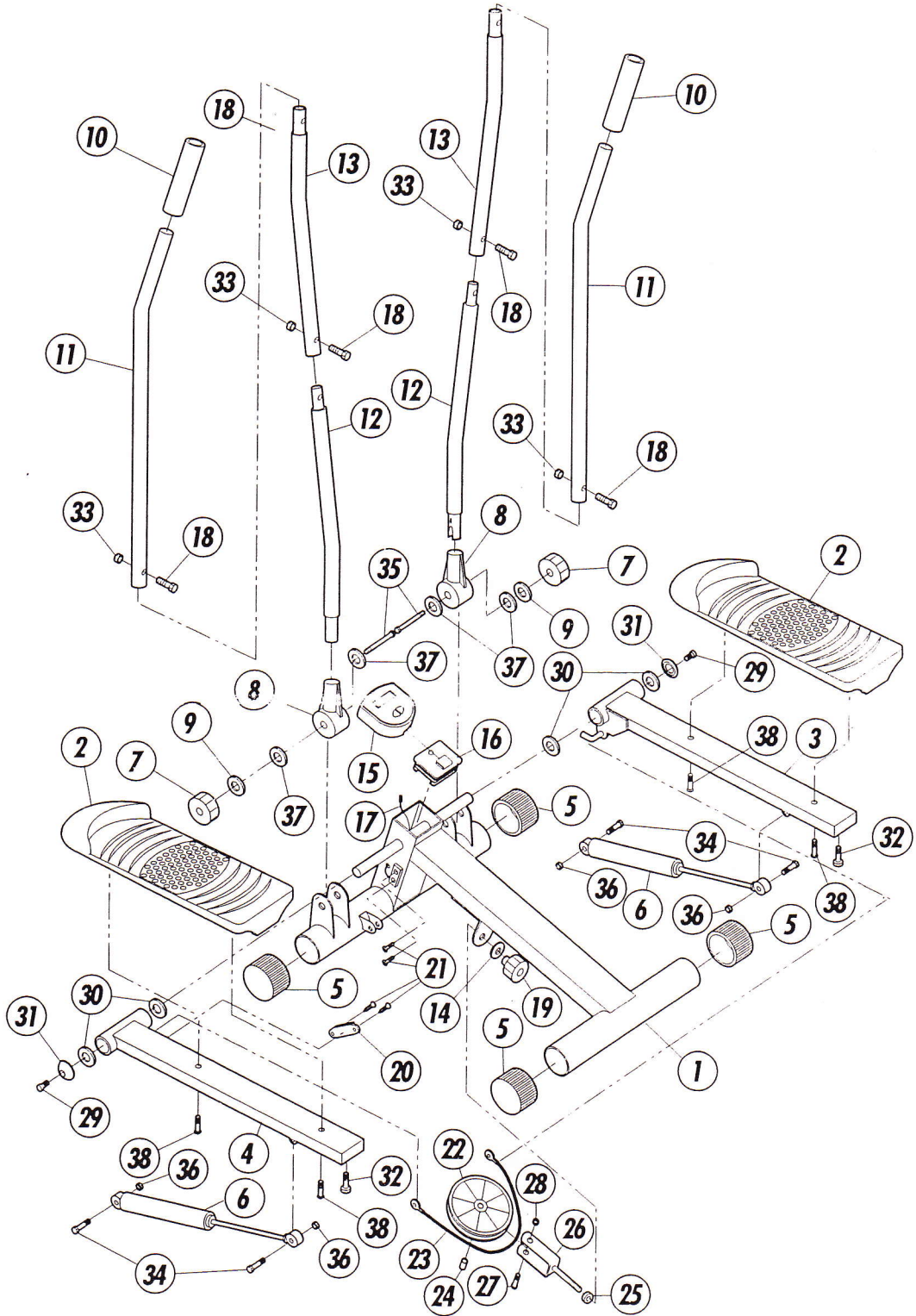

THANK YOU FOR YOUR COOPERATION

Should you have any questions,

please call our Customer Service Department, Monday through Friday, 8:00am until 4:00pm Pacific time (excluding holidays), at: 1.888.535.8637.

Please have the following information ready before placing your call:

- >Your name
- >Your address
- >Your telephone number
- >Model number
- >Parts order number
- >Serial number

Many times product assembly questions can be handled by our customer service personnel.

Please call us first if you are having problems.

Any return of our products will require all of its original contents, such as packing material, packing box, components, hardware, etc.

Please note that there is a weight limitation for this product. **If you weigh more than 250lbs. it is not recommended that you use this product. Serious injury may occur if the user's weight exceeds the limit shown here.** This product is not intended to support users whose weight exceeds this limit.

BEFORE BEGINNING

Gather your tools

Before starting the assembly of your unit, make sure that you have gathered all the necessary tools you may require to assemble the unit properly. Having all of the necessary equipment at hand will save time and make the assembly quick and hassle-free.

Clear your work area

Make sure that you have cleared away a large enough space to properly assemble the unit. Make sure space is free from anything that may cause injury during assembly. After the unit is fully assembled, make sure there is a comfortable amount of free area around the unit for unobstructed operation.

Invite a friend

Some of the assembly steps may require the help of another individual. Invite a friend to help with the assembly of your new exercise equipment. It is not only safe, but fun!

Open the boxes

When you have completed the steps **BEFORE BEGINNING**, you are now ready to open the boxes of your new unit. Make sure to inventory all of the parts that are included in the boxes. Check the Hardware Comparison Chart for a full count of the number of parts included for this product to be assembled properly. If you are missing any parts, please **DO NOT TAKE THE UNIT BACK TO THE RETAIL STORE.** Instead, call our Customer Service Department, Monday through Friday, 8:00am until 4:00pm, Pacific time (excluding holidays), at: 1.888.535.8637.

Make sure that you have the following information ready before placing your call:

- >Your name
- >Your address
- >Your telephone number
- >Model number
- >Parts order number
- >Serial number

call us first