

SPENDO – MONO BASIN MIXER

Barcode: 5090208001003

Product Code: SPO001

Finishes: Chrome

Product Type: Mono Basin Mixer

Water Pressure: MP – 0.5 bar Pressure Minimum

Standards: BS EN 200

Weights: 1.683KG

Notes: Supplied with Flexi Tails and Fittings and Push Waste

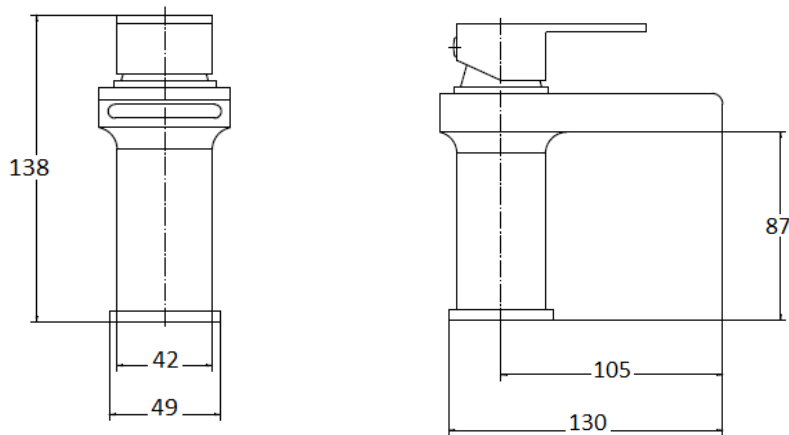
Technical Drawing

Flow Rate

0.1 BAR L.P 1	5 L/M
0.2 BAR L.P 2	6.2 L/M
0.5 BAR M.P	7.8 L/M
1.0 BAR H.P 1	10 L/M
2.0 BAR H.P 2	12 L/M
3.0 BAR H.P 3	16.5 L/M

Packaging Details

CODE:	Description	INDIVIDUAL BOX SIZES (CM)	WEIGHTS (KG)	PRODUCTS PER CARTON	CARTON SIZE	CARTON WEIGHT COMPLETE
SPO001	Spendo Mono Basin Mixer	22*14.5*9	1.683	10	46*38*20	18