

WIND – BATH FILLER

Barcode: 5093608801006

Product Code: WND003

Finishes: Chrome

Product Type: Bath Filler

Water Pressure: LP2 – 0.2 bar Pressure Minimum

Standards: BS EN 200

Weights: 3.125KG

Notes: Supplied with Fittings

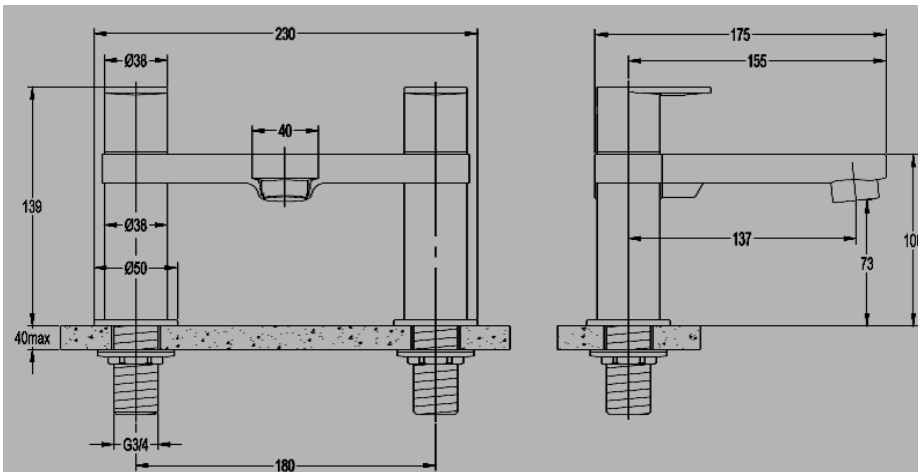
Technical Drawing

Flow Rate

0.1 BAR L.P 1	10 L/M
0.2 BAR L.P 2	16 L/M
0.5 BAR M.P	21 L/M
1.0 BAR H.P 1	24 L/M
2.0 BAR H.P 2	28 L/M
3.0 BAR H.P 3	32 L/M

Packaging Details

CODE:	Description	INDIVIDUAL BOX SIZES (CM)	WEIGHTS (KG)	PRODUCTS PER CARTON	CARTON SIZE	CARTON WEIGHT COMPLETE
WND003	Wind Bath Filler	26.5*20.5*20	3.125	8	55*42.5*42	24