

DAL006 - NERO BASIN TAPS

ILLUSTRATION: Dalton Basin Taps



BAR CODE : 0902077

COLOUR: CHROME

WIEIGHT:

NET = 1.100KG

GROSS = 1.530KG

STANDARDS : BS EN 200

NOTES:

FLOW RATES

0.1 BAR L.P 1	0.2 BAR L.P 2	0.5 BAR M.P	1.0 BAR H.P 1	2.0 BAR H.P 2	3.0 BAR H.P 3
3.2 L/M	5.5 L/M	8 L/M	10 L/M	14 L/M	18.8 L/M

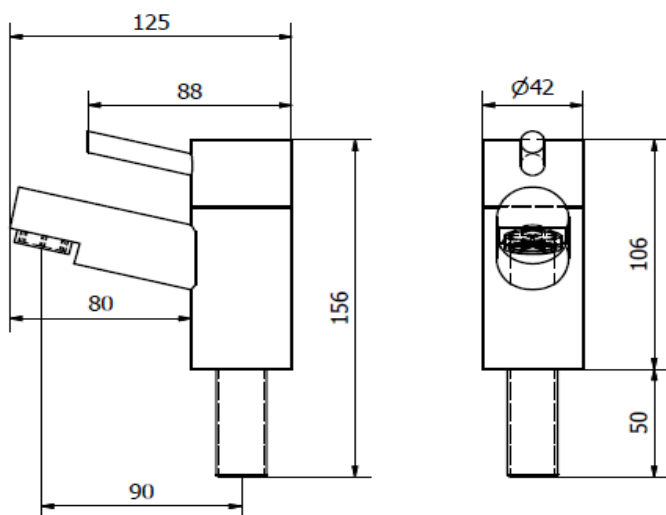
LINE DRAWING

PACKAGING DETAILS

INDIVIDUAL BOX SIZE (CM)	WEIGHTS (KG)	PRODUCTS PER CARTON	CARTON SIZE	CARTON WEIGHT COMPLETE
22.5*14.5*9	1.53	10	46*38*20	16.1