

**WIND – MONO BASIN MIXER**

Barcode: 5093608601002

Product Code: WND001

Finishes: Chrome

Product Type: Mono Basin Mixer

Water Pressure: MP – 0.5 bar Pressure Minimum

Standards: BS EN 200

Weights: 1.27KG

Notes: Supplied with Flexi Tails and Fittings – No Waste Supplied



### Technical Drawing

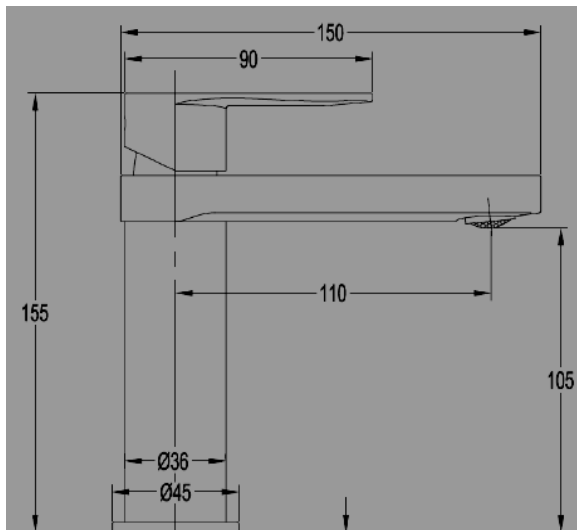

### Flow Rate

0.1 BAR L.P 1	2 L/M
0.2 BAR L.P 2	2.5 L/M
0.5 BAR M.P	3.2 L/M
1.0 BAR H.P 1	5.5 L/M
2.0 BAR H.P 2	7 L/M
3.0 BAR H.P 3	8.5 L/M

### Packaging Details

CODE:	Description	INDIVIDUAL BOX SIZES (CM)	WEIGHTS (KG)	PRODUCTS PER CARTON	CARTON SIZE	CARTON WEIGHT COMPLETE
WND001	Wind Mono Basin Mixer	32*18.5*6.5	1.27	18	57.5*33*42	23