



# PIT BOSS OWNERS MANUAL

SAVE THESE INSTRUCTIONS, TIPS & RECIPES INSIDE!

*Pit Boss 820FB*

BLACK  
(PB820FB)



*Pit Boss 820 Deluxe*

(PB820D)



Intertek

**NEW! INCLUDES FLAME BROILER**

**WARNING:** Please read the entire manual before installation and use of this pellet fuel-burning appliance. Failure to follow these instructions could result in property damage, bodily injury or even death. Contact local building or fire officials about restrictions and installation inspection requirements in your area.



DISCOVER THE WOOD PELLET GRILL ADVANTAGE

# Dangers & Warnings

**“A MAJOR CAUSE OF FIRES IS FAILURE TO MAINTAIN REQUIRED CLEARANCES (AIR SPACES) TO COMBUSTIBLE MATERIALS. IT IS OF UTMOST IMPORTANCE THAT THIS PRODUCT BE INSTALLED ONLY IN ACCORDANCE WITH THESE INSTRUCTIONS.”**

**WARNING:**

**YOU MUST** contact your local home association, building or fire officials, or authority having jurisdiction, to obtain the necessary permits, permission or information on any installation restrictions, such as any grill being installed on a combustible surface, inspection requirements or even ability to use, in your area.

- **YOU MUST** keep the entire grill a minimum 12 inches, or a safe distance, from all combustibles.
- **DO NOT** install or operate the grill under a combustible ceiling or overhang.
- **DO NOT** use indoors, or in an enclosed, unventilated area.
- **YOU MUST** clean and maintain your grill on a regular basis.
- **YOU MUST**, after a period of storage, and/or non-use, check the burn grate for obstructions, foreign objects both inside the grill and the hopper, and air blockage, before use. See instructions in this manual for correct procedures.
- **DO NOT** put a barbeque cover or anything flammable, on or in the storage space area under the barbeque.
- **DO NOT** allow children to use your Pit Boss Pellet Grill while unattended. Accessible parts of the barbeque may be very hot. Keep young children and pets away while it is in use.

**WARNING:**

**This appliance is not intended for use by persons (including children) with reduced physical, sensory or mental capabilities, or lack of experience and knowledge, unless they have been given supervision or instruction concerning use of the appliance by a person responsible for their safety.**

- **DO NOT** use lava rock, wood chucks, wood shavings or charcoal in your Pit Boss Pellet Grill.
- **DO NOT** use accessories not specified for use with this appliance.
- **YOU MUST** should a grease fire occur, turn “Off” the control and leave lid closed until the fire is out. **DO NOT** unplug the power cord. **DO NOT** throw water on it. **DO NOT** try to smother the fire.
- **YOU MUST** use heat-resistant barbeque mitts or gloves when operating barbeque.

**WARNING:**

**DO NOT transport your Pit Boss Pellet Grill while operating or while the grill is HOT. Make sure the fire is completely out and that the grill is completely “Cool to the Touch”**

- **DO NOT** enlarge burn grate orifices, igniter holes or burn pots.
- **DO NOT** use your grill in the rain or around any water source.
- **YOU MUST ALWAYS** unplug the grill before performing any service or maintenance .
- If the grill is stored outside during the rainy season or seasons of high humidity, care should be taken to insure that water does not get into the pellet hopper. Wood pellets, when wet or exposed to high humidity, expand greatly, break apart, and could jam the feed system.
- **DISPOSAL OF ASHES** — Ashes should be placed in a metal container with a tight-fitting lid. The closed container of ashes should be placed on a non-combustible floor or on the ground, well away from ALL combustible materials, pending final disposal. When ashes are disposed by burial in soil or otherwise locally dispersed, they should be retained in the closed container until all cinders have thoroughly cooled.

**WARNING:**

**DO NOT touch any part of your Pit Boss Series Pellet Grill while the smoker is HOT. Serious bodily injury could result.**

# Dangers & Warnings

**WARNING:**

**DO NOT over-fire your “Pit Boss”. Improper Use Can Cause Uncontrolled Fire.**

## FUEL—WOOD PELLETS

- **YOU MUST only use** all natural wood pellets, designed for burning in pellet bbq grills. Any other type of fuel burn in this appliance will void the warranty and safety listing.
- **DO NOT** use fuel labeled as having additives.
- At this time of printing, there is no “Standard” for BBQ wood pellets, although most pellet mills do use the same standards used to make “Home Heating” wood pellets. Further information on this “Standard” can be found at [www.pelletheat.org](http://www.pelletheat.org) or the Pellet Fuel Institute.
- Check with your local dealer on the quality of pellets in your area and for information on what can be expected from various brands.
- **NOTE:** Since Dansons Inc. has no control over the quality of pellets, that you use, we assume no liability caused by the quality of fuel used.

**CAUTION:**

**DO NOT use spirit, petrol, gasoline, lighter-fluid or kerosene for lighting or refreshing a fire in your grill.**

## CREOSOTE

- **DO NOT** operate the appliance if the flame becomes dark and sooty or if the burn pot overfills with pellets. Turn the unit OFF, let the appliance cool completely, and then inspect the unit. Soot or Creosote may accumulate in the main barrel and along any air leakage or exhaust areas when the appliance is operated under incorrect conditions, such as incorrect burn grate position, blockage of the combustion fan, failure to clean and maintain the burn area, etc.
- Soot or creosote is formed when pellets are burned without the correct amount of air to fuel or incomplete combustion, thus producing a tar like substance and other organic vapours that combine with expelled moisture. The smoke will have a black color to it and the residue left behind on surfaces, will also be black in color.
- When ignited, this creosote makes an extremely hot and out of control fire, similar to a grease fire.
- If creosote has formed within the unit; allow the unit to warm up at a LOW temperature, turn OFF the appliance, then wipe out any formation with a hand towel. Creosote is similar to tar, when warmed it will become like liquid, and is much easier to clean in this state.

**WARNING:**

**IF A UNCONTROLLED FIRE DOES OCCURE: CALL FIRE DEPARTMENT.  
DO NOT try to move appliance. DO NOT try to smother the fire. DO NOT put water on the fire.**

## CARBON MONOXIDE: “The Silent Killer”

FOLLOW THESE GUIDELINES TO PREVENT THIS COLORLESS, ODORLESS GAS FROM POISONING YOU, YOUR FAMILY OR OTHERS:

- Know the symptoms of carbon monoxide poisoning: Headaches, Dizziness, Weakness, Nausea, Vomiting, Sleepiness, and Confusion. Carbon Monoxide reduces the blood’s ability to carry oxygen. Low blood oxygen levels can result in loss of consciousness and death.
- See a doctor if you or others develop cold or flu-like symptoms while cooking or in the vicinity of the appliance. Carbon monoxide poisoning, which can easily be mistaken for a cold or flu, is often detected to late.
- Alcohol consumption and drug use increase the effects of carbon monoxide poisoning.
- Carbon monoxide is especially toxic to mother and child during pregnancy, infants, the elderly, smokers, and people with blood or circulatory system problems, such as anemia, or heart disease.

**CAUTION!**

**To prevent fingers, clothing or other objects from coming in contact with the auger, your appliance has been equipped with a metal screen, mounted inside the hopper. This screen MUST NOT be removed unless directed by Dansons Customer Service or Authorized service personal.**

# INTRODUCTION



THANK YOU!

**Congratulations on your purchase of this “Pit Boss” Pellet Smoker/Grill.**

With the proper set-up, operation and maintenance, this BBQ will provide you with years of cooking enjoyment, never ending compliments and will allow you to produce **“Competition Quality BBQ In Your Own Back Yard”**.

Think of your **“Pit Boss”** as an extra stove available to bake, roast, grill and smoke food.

Barbecuing provides a form of entertainment, which is relaxed and casual. Your meals can be completely cooked outdoors and it is where the chef (Pit Boss) is one of the crowd.

We'd like to take this opportunity to pass on a few **important tips** concerning grilling with wood pellets.

1. **Initial set-up of our “Pit Boss” is the most important step** to ensure the efficient and satisfactory operation of your barbecue for many years to come.
2. **Be diligent in your cleaning and maintenance program.** Taking care of your grill will add years of life and keeps it looking great.
3. **Use only all natural wood pellets designed to burn in pellet grills.**
4. **Ensure your pellet fuel stays moisture free.** Open bags of fuel should be stored in an airtight container and empty the hopper if you are not using the grill over longer periods of time.

Again, **Thank You!**

---

## IMPORTANT NOTE:

---

Be sure to inspect entire grill after removing the protective shipping carton.

Report any damage to your local dealer immediately.

Shipping damage is not covered under warranty.

---

## SAFETY TESTING

In accordance with the procedures and specifications listed in UL SUBJECT 2728-2009 “PELLET FUEL COOKING APPLIANCES” AND ULC/ORD C2728 & CANADIAN CSA C22.2 #3 “FOR ELECTRICAL FEATURES OF FUEL BURNING EQUIPMENT”. The Pit Boss series of pellet cooking appliance has been independently tested and listed by INTERTEK (an accredited testing laboratory) to ETL, UL, ULC and CSA standards.



Intertek



This product has been assessed and meets EU (European Economic Area) safety, health and Environmental protection requirements.

Please read the label found attached to the inside lid of the hopper, carefully. It contains important information about installation and operation of your pellet cooking appliance.

# CONTENTS

DANGERS & WARNINGS	2
SAFETY TESTING	4
UNPACKING YOUR PIT BOSS SMOKER	6
<b>ASSEMBLY INSTRUCTIONS</b>	
LEGS & SHELF	7
CART & STOPPER	8
HANDLE, THERMOMETER, & STACK	9
SIDE SHELF & BUCKET	10
WORKING COMPONENTS	11
POWER & PREPERATION	12
<b>KNOWLEDGE IS POWER</b>	
HOW YOUR PIT BOSS SMOKER WORKS	13
SPECS	14
ABOUT WOOD PELLETS	22
<b>OPERATION</b>	
GETTING STARTED	15
PIT BOSS CONTROL	16
LIGHTING - AUTOMATIC / MANUAL	19
SHUTTING OFF YOUR SMOKER	21
<b>MAINTENANCE</b>	
21	
<b>GRILLING TIPS AND TECHNIQUES</b>	
22	
<b>TROUBLE SHOOTING</b>	
26	
<b>PARTS LIST</b>	
29	
<b>GRILL RECIPES</b>	
31	
<b>LIMITED WARRANTY</b>	
38	



When you open your smoker/grill, please ensure you have and can identify all the following parts:

**NOTE:** Numbers following part names throughout this manual refer to the component diagram below.

### Parts List

Item	Part #	Description	QTY
1.	76122	Upper Rack	1
2.	74035	Cooking Grids	2 or 3
3.	74516	Flame Broiler—main	
4.		Flame Broiler—slide	
5.	74322	Handle—Chrome	1
6.	74228	Bezel, (decorative washer)	2
7.		Barrel & Hopper Assembly	1
8.	74321	Leg w/ Wheel axle (right hand side end)	2
9.		Bottom Shelf	1
	74347	820FB—Open Grid	
	74348	820Deluxe—Solid	
10.	74086	Metal Wheel	2
11 a.	74322	Back Leg (hopper end)	1
11 b.	74323	Front Leg w/bottle opener (hopper end) * Deluxe models only	1
12.	74400	Grease Bucket	1
13.		Handle—Side (tray holder)	1
	74222	820Deluxe—Stainless	
14.	74080	Smoke Stack	1
15.	74801	Smoke Stack—Gasket	1
16.	74402	Dome Thermometer	1
17.	74403	Lid Stopper	1
18.	74328	Bottle Opener (820Deluxe only)	1
19.	74223	Serving Tray (820DG only)	1

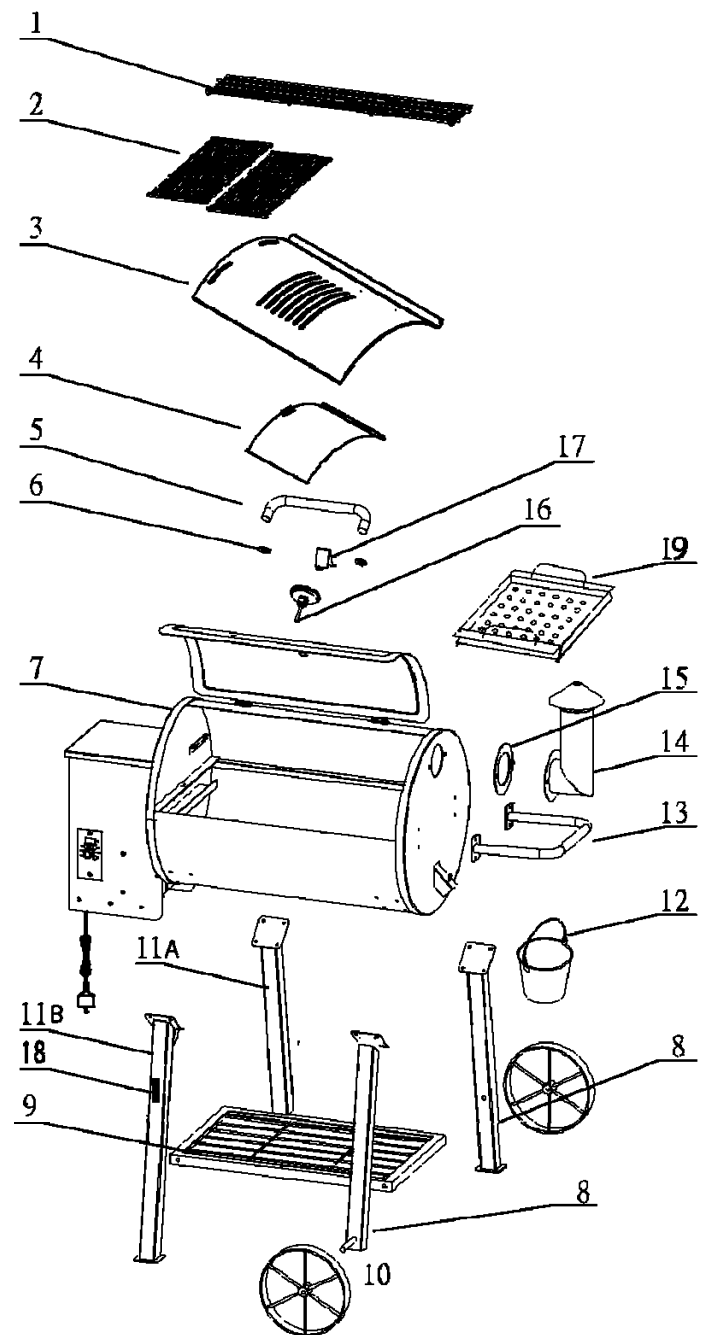

### Hardware List — # 74401

Part No.	Description	Diagram	Qty
<b>AA</b>	Screw 1/4" - 20* 3/5"		29
<b>CC</b>	Washer 12.5 x 24		2
<b>BB</b>	Lock Nut 7/16" - 20		2

# Section One: ASSEMBLY INSTRUCTIONS

## ASSEMBLING & MOUNTING THE LEGS & SHELF

### Parts Needed:

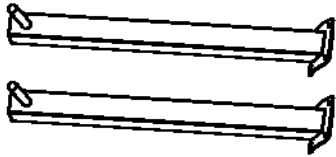

2 Legs w/ axels

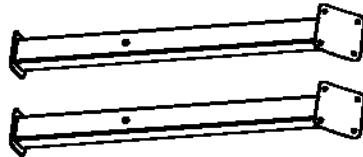

2 Legs

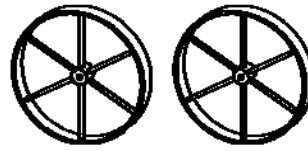

2 Metal Wheels

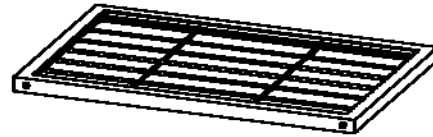

1 Bottom Shelf  
820FB—Open Grid  
820Deluxe—Solid

### Hardware Required:



Screw 1/4"- 20\* 3/5" x 20 (AA)



Washer 12.5 x 24 x 2 (CC)



Lock Nuts 7/16" x 2 (BB)

### Tools Required:

- 1—7/16" Open End Box Wrench
- 1— Adjustable Crescent Wrench  
Or
- 1— Phillips Screwdriver



### Installation Steps

#### Step 1 Attach legs to barrel:

- To ease installation, gently lay the barrel on its end, **not the hopper end**. A piece of cardboard or blanket should be placed under the grill to prevent scratching the finish.
- Using the proper tool, install the 2 legs **WITHOUT** the wheel axles to the top of the barrel. (hopper end)  
Part # 11a & 11b  
**Reminder: Leg with Bottle Opener faces out toward the front of the grill.**  
Fasten all four 1/4" - #20 x 3/5" screws (AA) through the four pre-drilled screw holes both on the leg and on the bottom of the barrel. Hand start, then use tool. **FASTEN ONLY, DO NOT TIGHTEN AT THIS POINT. THIS ALLOWS FOR EASIER INSTALLATION OF BOTTOM SHELF.**
- Install the 2 legs **WITH** the wheel axles to the bottom of the barrel. Part # 8  
Fasten all four 1/4" - #20 x 3/5" screws (AA) through the four pre-drilled screw holes both on the leg and on the bottom of the barrel. Hand start then use tool. **FASTEN ONLY, DO NOT TIGHTEN AT THIS POINT.**

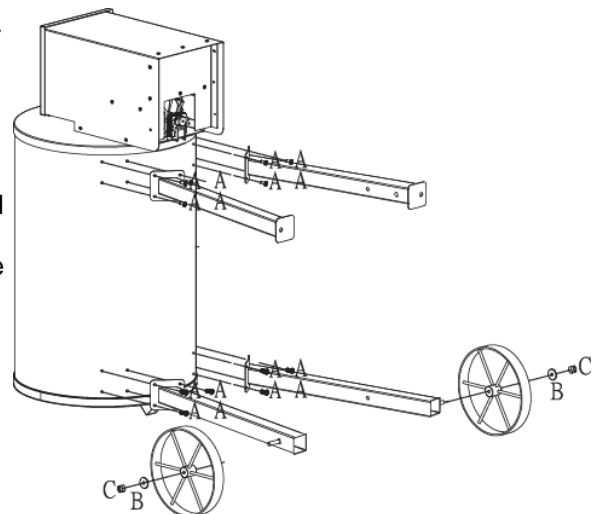

# Section One: ASSEMBLY INSTRUCTIONS

## ASSEMBLING & MOUNTING THE CART ... CONT

### Step 2 Install Bottom Shelf Assembly:

Models 820FB—Open Shelf    Model 820Deluxe—Solid Shelf

- Install the Bottom Shelf to all four legs.  
Using 4 of the 1/4" x #20 x 3/5" screws (AA) and your Screw driver, hand start then secure the screws firmly to the leg frame.

Note: Ensure the shelf is installed so the flat surface is facing up

- NOW, securely tighten ALL 16 leg screws (AA)

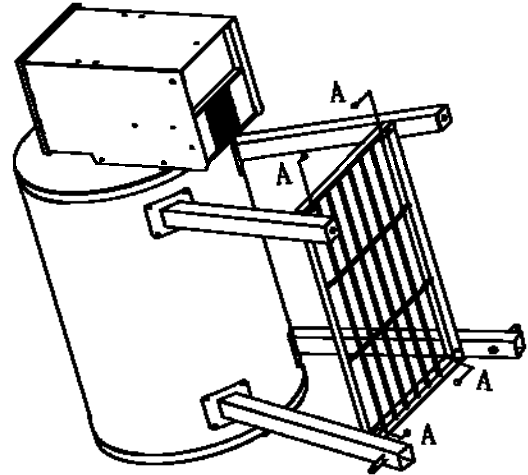

### Step 3 Install Wheels to Leg Assembly:

- Slide metal wheel onto either leg with the axle
- Install washer (CC), then hand screw the 7/16" x 20 Nut (BB) onto the threaded axle. Use your wrench to tighten.
- Spin each wheel to ensure the wheels turn freely.
- Carefully lift barrel and attached leg assembly to the upright position.

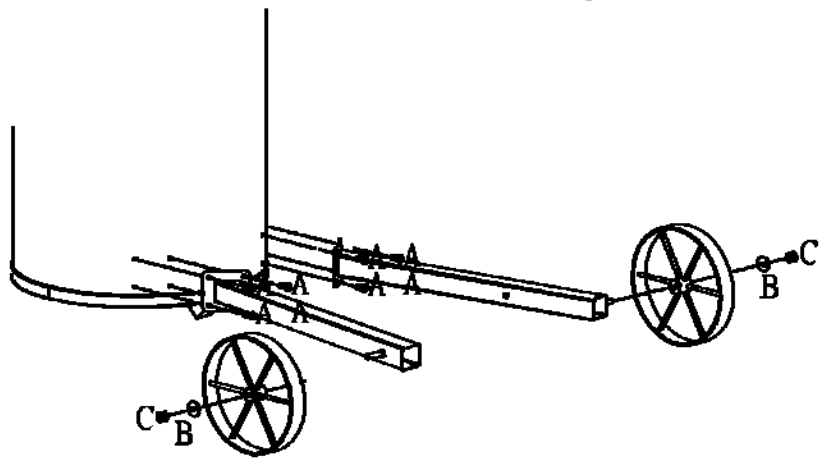

## ASSEMBLING—LID STOPPER

### Parts Needed:



### Hardware Required:

Screw 1/4"- 20\* 3/5" x 1 (AA)

### Installation Steps

#### Step 1 Attach Lid Stopper

- Slip the Lid Stopper front lip into the slot provided  
Located at the top of the barrel in the middle.
- Using the screw driver, secure the Lid Stopper to the barrel with one 1/4" - #20 x 3/5" (AA) screw.  
Take care not to over-tighten.

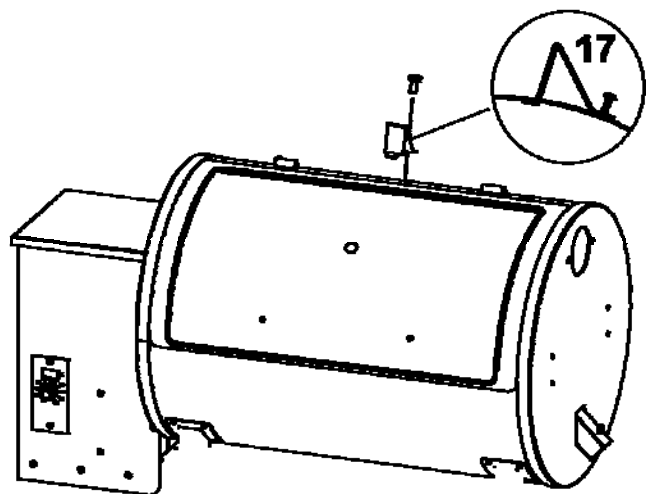



# Section One: ASSEMBLY INSTRUCTIONS

## ASSEMBLING THE LID HANDLE

### Parts Needed:



- 5 Lid Handle
- 6 Decorative Washers x 2 (Bezels)
- Insulation Cardboard

### Hardware Required:

- ☛ Screw 1/4"- 20\* 3/5" x 2 (AA)

### Installation Steps

- Insert one screw (A) from inside the lid, through the hole provided in the lid.
- Place one Bezel (6) over the screw, then line-up the handle (5) with the threaded end of the screw.
- Hand start the screw into the handle,
- Repeat procedure for other end of handle.
- Using your wrench securely tighten ALL screws (A)

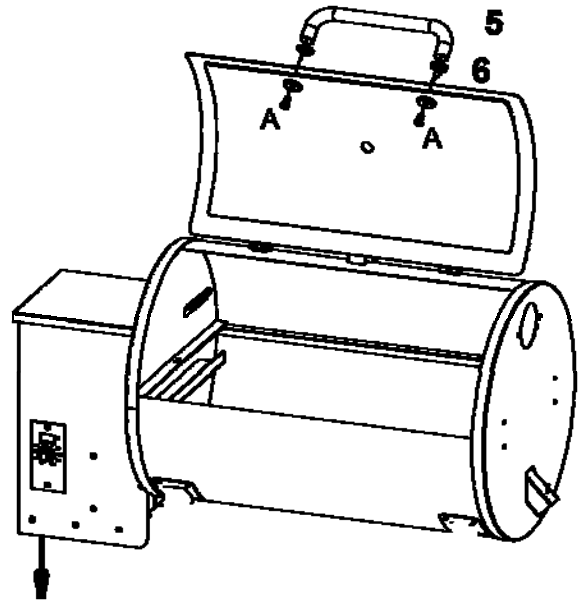

## ASSEMBLING THE DOME THERMOMETER

### Part Needed:

- 16 Dome Thermometer



### Installation Steps

- The thermometer comes complete with its own threaded nut already installed on the thermometer.
- Simply spin off the threaded nut, and insert the thermometer through the hole provided in the top of the hood, Then firmly hand tighten the nut back onto the thermometer.

**Note:** Take care not to turn the face of the thermometer. This will result in incorrect readings.

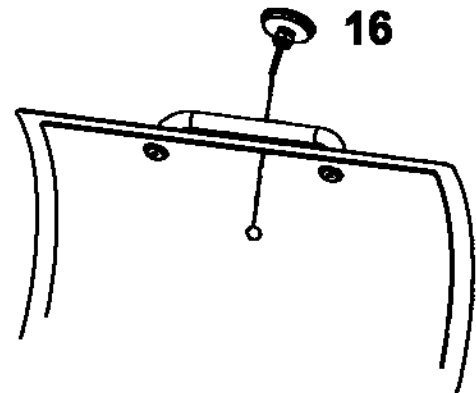

## ATTACHING THE SMOKE STACK

### Parts Needed:

- 14 Smoke Stack
- 15 Smoke Stack Gasket

### Hardware Required:

- ☛ Screw 1/4"- 20\* 3/5" x 2 (AA)

### Installation Steps

- Using the 2 screws (AA) insert them through the stack section, through the gasket, then finally through the barrel end.
- Hand start, then secure in place using your Phillips Screwdriver.
- NOTE: DO NOT lower the chimney cap tight to chimney stack. You must allow air to escape.

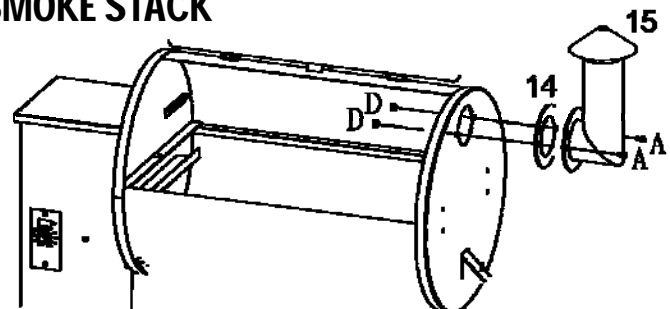

# Section One: ASSEMBLY INSTRUCTIONS

## ATTACHING THE SIDE SHELF HANDLE

### Part Needed:

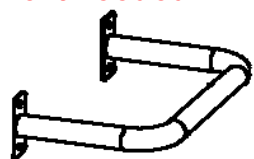

- #13 Tray Holder— 820Deluxe Stainless
- 2 Insulated Felt Spacers

### Hardware Required:

- ☐ Screw 1/4"- 20\* 3/5" x 4 (AA)

### Installation Steps

- Using your wrench secure all four screws (A) through the handle (13) and insulated felt spacers, onto the barrel.
- Ensure a tight fit, without over tightening.

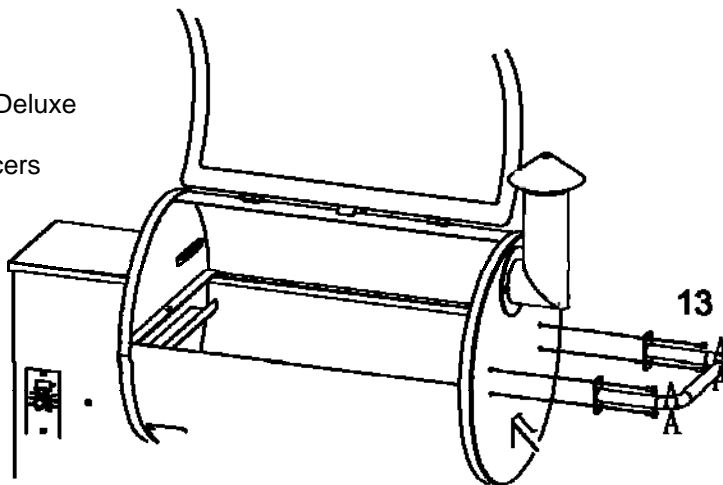

**IMPORTANT:** DO NOT use the Chrome Side Shelf Handle to move or lift the unit. Because of the size, **it will break**. This is not a warranty item.

## ATTACHING THE GREASE BUCKET

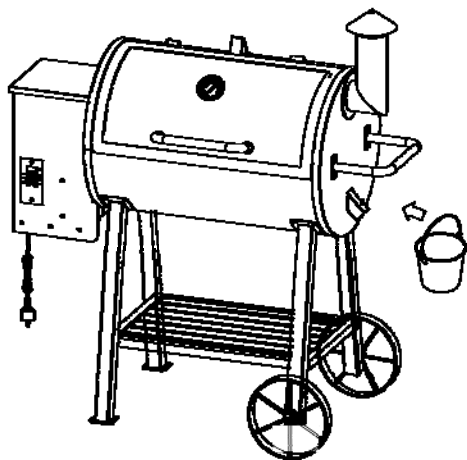

## ATTACHING THE SERVING TRAY

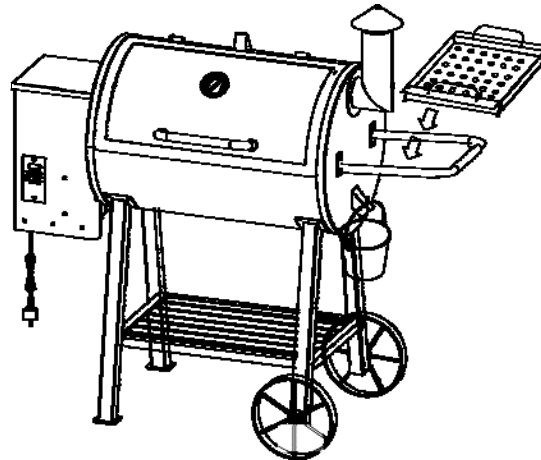

## PLACING THE COOKING COMPONENTS

### COOKING GRIDS (2)

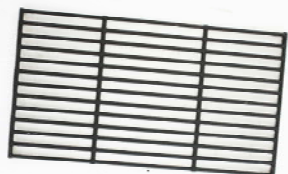

Your Pit Boss grill comes with Cast Iron cooking grids. Cast Iron is an excellent heat absorber and is still the best way to produce those “steak house” sear markings.

NOTE: To maintain the searing and grilling performance of your cooking grids, as well as their longevity, some special care and maintenance is required as with any cast iron cooking tools.

### UPPER COOKING RACK (1)



Place this Porcelain Coated steel grid on to the two brackets found on either end of the barrel

# Section One: ASSEMBLY INSTRUCTIONS

## PLACING THE COOKING COMPONENTS

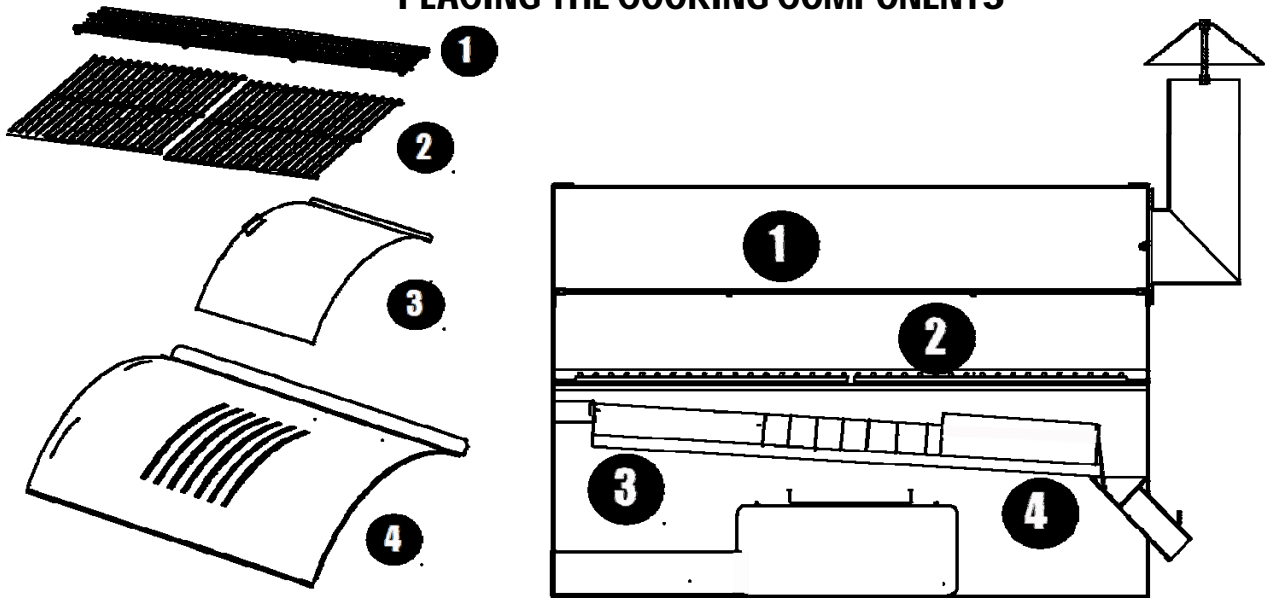

### Parts Needed:

**Model 820FB & 820D**  
Upper Cooking Rack  
Cooking Grids  
2 pc Flame Broiler

### FLAME BROILER / SLIDER (3 & 4)

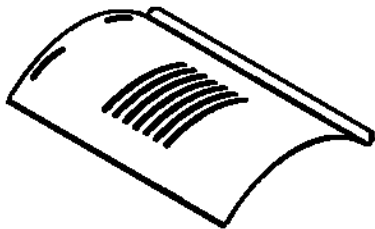

The Pit Boss Flame Broiler allows you to choose from either indirect or direct cooking, as well as to channel the extra grease toward the grease bucket. When hot the excess grease and juice evaporate to add more natural flavor back into whatever you are cooking.

- Hook the longer arched and slotted steel broiler, on to the holder located at the hopper end, just below the cooking grid standoffs. The other end will sit in the notches found on the grease catch tray. **(A)**
- The smaller plate is used to slide over the openings of the larger plate, to open or close the access to the flame. **(B)**



**NOTE:** When using the direct cooking method, **DO NOT** leave grill unattended.

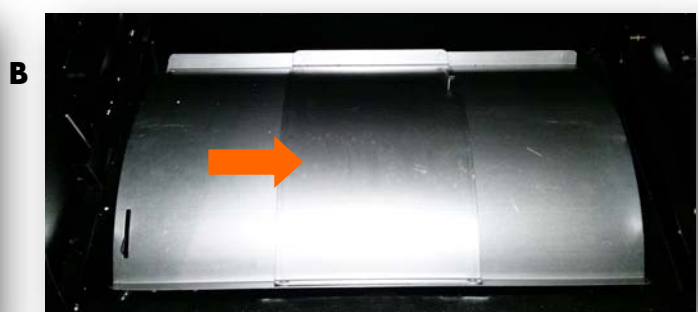

# Section One: ASSEMBLY INSTRUCTIONS

## HOOKING UP TO POWER

**NOTE:** Before plugging your Pit Boss into any electrical outlet ensure the Temperature Dial is in the “OFF” position.



### AT HOME

- This appliance requires 110 Volt, 60Hz, 5 amp service.
- It must use a 3 prong grounded plug.
- The control uses a 5 amp 120Volt Fast-Blow fuse to protect the board from the igniter.

### GFI Outlets

- This appliance will work on most GFI Outlets. Recommended size 15 amp.
- If your GFI outlet is highly sensitive to power surges, it will very likely trip during the ignition phase of operation. During the ignition phase, the igniter is drawing 300—700 watts of electricity which can be too much power for a GFI outlet to handle. The quality of the GFI does not matter, rather the sensitivity matters. Each time a GFI trips it does increase in sensitivity.



- Solution:** 1. Install a brand new GFI .  
2. Plug the appliance into a non-GFI outlet.

### ON THE ROAD

- By disconnecting the Igniter, from the main wiring harness, your Pit Boss can be run using a 12 volt , 100 watt inverter plugged into your automobile outlet. Then light your smoker using the manual method. (found in lighting instructions)
- If you do want to continue to use the automatic igniter, it is recommended to use a minimum of a 1000 watt inverter.



## GRILL PREPERATION

### INITIAL FIRING INSTRUCTIONS

These instructions should be followed the first time the grill is ignited and each time the grill runs out of pellets.

#### STEP 1

Remove Cooking Grids and Flame Broiler from the interior of the grill.

#### STEP 2

Open the Pellet Hopper Lid. Make sure there are no foreign objects in the Auger or Hopper.

#### STEP 3

With the Temperature Dial in the OFF position, plug the power cord into a grounded outlet.

#### STEP 4

Turn the Temperature Dial to the SMOKE position.

Check the following items:

A. That the Auger is turning.

DO NOT place fingers or objects in the Auger Tube. This can cause injury.

B. Place your hand OVER the Fire Pot and feel for air movement.

DO NOT place your hand in the Fire Pot. This can cause serious injury.

C, Wait approximately 1 minute you should smell the igniter burn off and start to feel the Air getting warmer. The igniter tip does not glow red hot.

DO NOT touch the Igniter. This item gets extremely HOT and will burn.

#### STEP 5

Turn the Temperature Dial to OFF.

#### STEP 6

Fill the Pellet Hopper with all natural BBQ pellets.

#### STEP 7

Turn the Temperature Dial to SMOKE. Allow the pellets to come to full flame. Once flames are coming out of the Fire Pot, turn the Dial to OFF, and let the grill cool down.

#### STEP 8

After grill has cooled, re-install the Flame Broiler and Cooking Grids into grill.

# Section Two: OPERATION

## HOW IT WORKS 101

**A** All natural wood bbq pellets are poured in the hopper. (3)

**B** Turn Temperature Dial (1) to the "OFF" setting.

**C** Plug the smoker / grill into a grounded, 110 volt, electrical outlet.

**D** Select the desired cooking temperature, using the Temperature Dial. (1)

- The Auger (6) begins to feed pellets from the Hopper (3) to the Burn Pot. (8)
- The Igniter (7) or hot rod, activates for 5 minutes, and along with the Draft Fan (5) ignite the pellets.
- The Draft Fan (5) causes the pellets to burn, clean and intense, like a miniature forge.

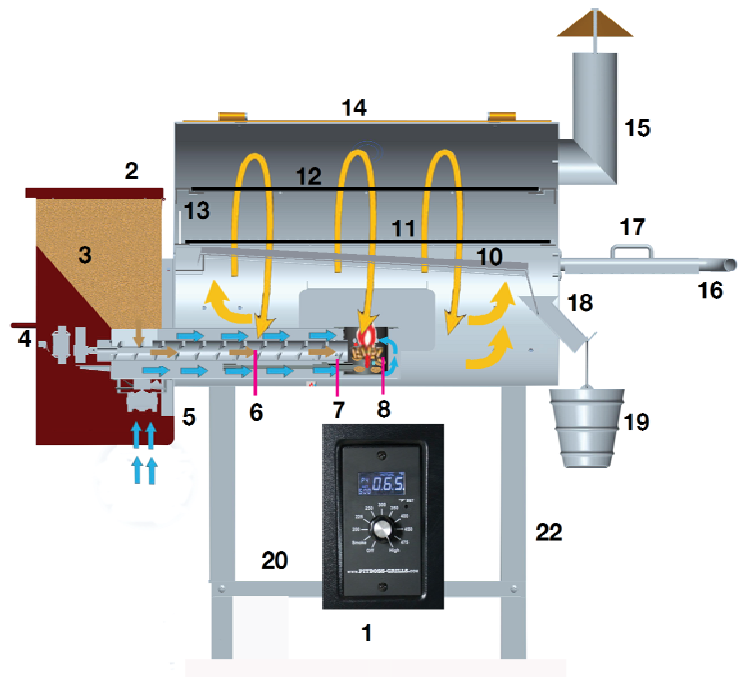

**E** The Draft Fan (5) also causes heat and "clean" wood smoke to surround the food, known as convection cooking.

- This is the key to making a effort free, juicy, and the most fantastic natural flavor.

**F** The wood pellet fuel burns in the Burn Pot (8) hot and intense. The fly ash and the flames hit the Flame Broiler (10) and are directed toward the ends of the barrel.

- The fly ash is collected in the bottom of the barrel and should be cleaned out periodically.

**G** Drippings from the food hit the hot Flame Broiler / Flavor Enhancer (10), vaporizing back into the food.

- Excess drippings are channeled to the Grease Chute (18) to the external bucket (19) for easy disposal.

**H** Select the desired cooking temperature (1)

- 180°F to 275°F, "Hot Smoke" fish, ribs, briskets
- 275°F to 325°F, "Bake or Slow Roast" chicken, lamb,
- 325°F to 375°F, "Bake" breads, cookies, desserts
- 400°F to 450°F, "Bake or Braise" pizzas, beef, veggies
- 500°F, "Steak House Sear" your steaks, burgers, dogs

**I** When finished creating your "Culinary Delight", simply lift the lid and turn the dial (1) to OFF.



# Knowledge is Power

## Your New 820FB & 820D Wood Pellet Fired Smokin Grills

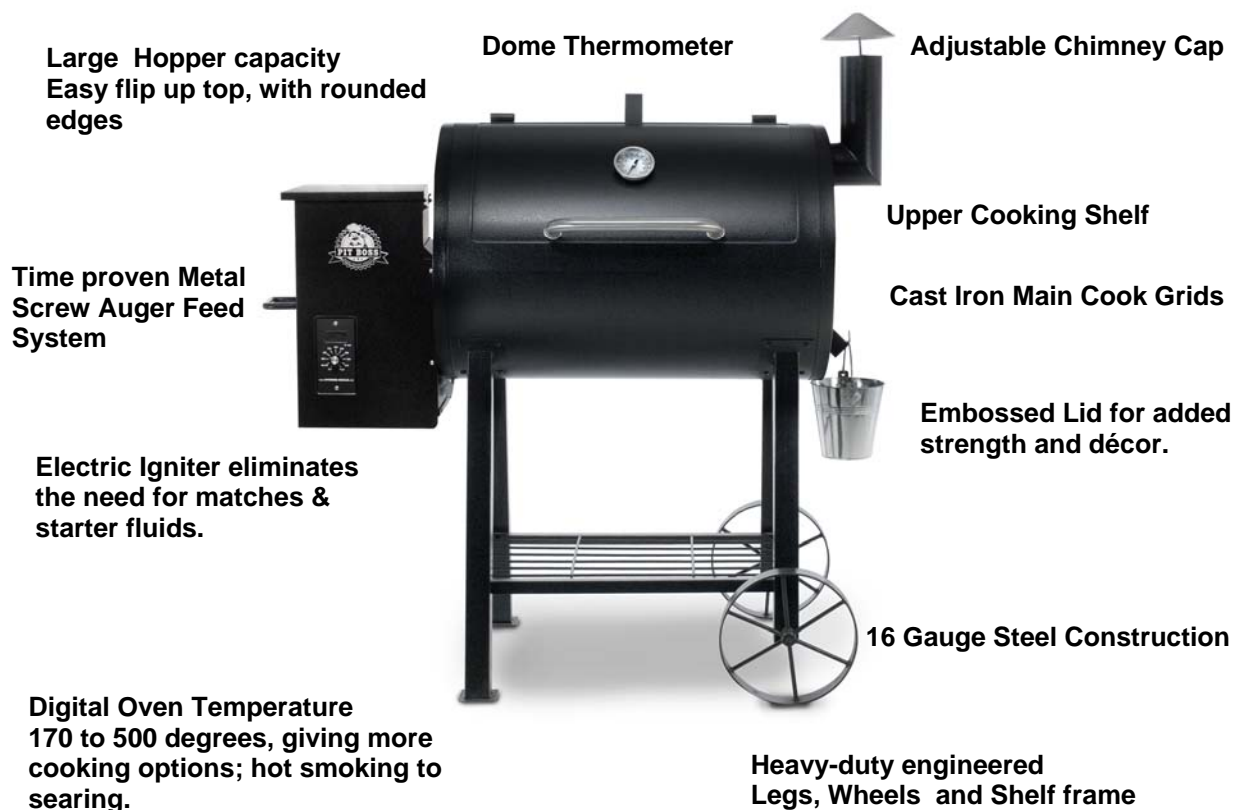

MODEL	UNIT	COOKING AREA	HOPPER	ELECTRIC	SIZE H X W X D	WEIGHT
PB	820FB	580 sq. in.—primary 240 sq. in.—upper	20 lb.	110Volt, 3.1amp 50Hz	50 x 49.25 x 24	141 lbs.
PB	820D_	580 sq. in.—primary 240 sq. in.—upper	24 lb.	Same	50 x 55.25 x 24	146 lbs.

### OPTIONS



#### Custom Cover

Silk Screened heavy duty 600 danier, polyester canvas, double stitched, Polyurethane interior, tightening strap.



#### Side Shelf for PB820FB

Stainless Steel tray holder. Complete with removable stainless grill tray / serving tray and tool hooks.

# Section Two: OPERATION

## GETTING STARTED

*With today's lifestyle of striving to eat healthy and nutritious foods, one factor to consider is the importance of reducing fat intake. One of the best ways to cut down on fat in your diet is to use a low fat method of cooking, such as grilling.*

*Throughout this manual, you will notice the emphasis on grilling food slowly at LOW or MEDIUM temperature settings. With the benefit of convection cooking, and the use of the "Flame Broiler", your "Pit Boss" Grill will enable you to avoid flare-ups and maximize the nutritional value of the foods that you cook.*

Following is a list of the important tips that will contribute to the cooking perfection that you can expect when using your Grill:

---

### Environment

As with all barbecues, the outside weather conditions will play a big part in the performance of your Pit Boss and the cooking times needed to perfect your culinary delights. Your "Pit Boss", because of its single wall construction, should be considered as a 2 to 3 season grill, depending on what part of the country you live in.

### Grill Placement

Your "Pit Boss" Pellet Grill should always be a minimum of 12 inches away from any wall or structure around the entire grill. Your grill does come with wheels, so the smoker and chimney stack can be turned away from the wind resulting in better temperature output. If you are able to shelter your grill from the wind, this will also aid in temperature output, heat retention, and heat recovery time when opening the lid.

### Operating the Grill

#### *Initial Burn Off*

Before cooking on your grill for the first time, we recommend that you "burn off" the grill to ride it of any foreign matter. Light and operate the grill on HIGH with the lid down for 30 – 40 minutes.

#### *Lighting your Grill*

**It is recommended practice to always clean your burn grate after every 1 to 3 uses.**

This will ensure proper ignition and many happy grilling experiences. Light as per instructions found in detail later in this manual.

Should your auto igniter refuse to ignite the wood pellets, it is easy to light your grill manually with a match and lighting agent. (refer to manual lighting instructions found elsewhere in this manual)

#### *Pre-Heating*

It is extremely important to ALWAYS allow your grill to preheat before cooking. This allows the grill and cooking grids to heat up quicker and the grill is able to maintain its cooking temperature once your food is placed in the cooking area. If you do not allow the grill to preheat, you will find that it takes a longer period of time to bring both the grill and the food to cooking temperatures.

Always pre-heat your "Pit Boss" Grill with the lid closed. ONLY after your Grill has ignited, close the lid and set your temperature control knob to HIGH for 10-15 minutes depending on weather. This gives you enough time to prepare your food for the grill; as well it is the final step in cleaning your cooking grids.

#### *Lid Position*

Always cook with the lid closed. Not only does this keep the temperature even, the food will cook faster, using less fuel. A closed lid also helps to create a smokier flavour. You can slow down your cooking by propping up the lid.

**IMPORTANT NOTE: You must OPEN the lid during both the "Start-Up" and "Shut Down" cycles.**

**Caution:** Grease fires are caused by not properly maintaining your grill, or failing to clean the bottom of the barrel on a consistent basis. In the unlikely event you experience a grease fire while cooking, keep the lid closed. If it does not go out in a very short time, open the lid and lightly sprinkle baking soda on the fire. Be careful not to burn yourself. If this does not work, then carefully remove the food, push the power button to OFF and shut the lid until the fire is completely out.

# Section Two: OPERATION

## PIT BOSS CONTROL

### OVERVIEW

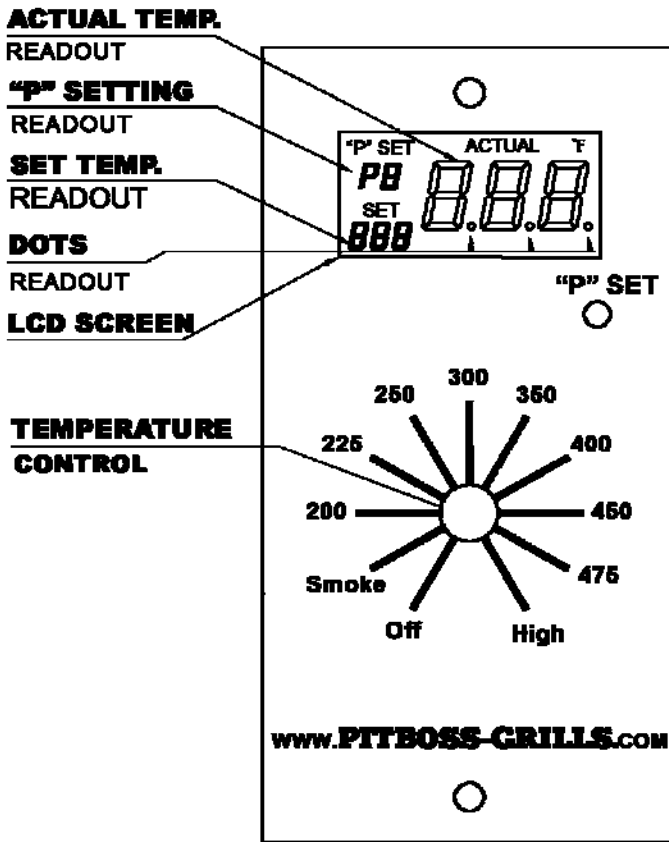

### LCD SCREEN

Displays Grill Temperature, Smoke Settings (P Setting), igniter and temperature status, and error

### TEMPERATURE DIAL

Select the following: Smoke, High, or one of 8 temperatures.

### "P" SET (recessed push button)

Select one of 7 temperature fine tunings. Allows for Larger temperature control to fit your cooking style

### HIGH - HIGH TEMPERATURE MODE

Grill operates at the Highest heat level. When Lid is "OPEN" the grill will run at this speed

### SMOKE - LOW TEMPERATURE MODE

Grill operates at the Lowest Temperature. This level can be adjusted as well, using the "P" Set button.

NOTE: This setting does not produce high volumes of visible smoke.

### OFF

Starts the "Cool Down Cycle". Turning off the Feed System, while letting the fan operate to efficiently cool down the grill for 2 minutes.

### LCD SCREEN READOUTS

#### 888

Displays momentarily when the grill is connected to AC power.

#### ACTUAL TEMPERATURE

Grill temp. is displayed in 5 degree (°F) increments.

#### FLASHING ACTUAL TEMPERATURE

When grill temperature is below 150°F.

#### FLASHING DOTS

Indicates when the Igniter is "ON".

#### "P" SETTINGS P0 - P7

When the Temperature Dial is in either the Smoke or High modes, "P 4" is the factory set default.

#### "ErH" FLASHING ERROR

Grill temperature has exceeded 615°F. .

#### "ErP" FLASHING ERROR

Temperature Dial was not in the OFF position when the grill was connected to AC power. Also indicated a Power Outage occurred while the grill was operating.

#### "ErR" FLASHING ERROR

Grill Probe malfunction or disconnected from board.



# Section Two: OPERATION

## CONNECTING TO AC POWER

### PIT BOSS CONTROL

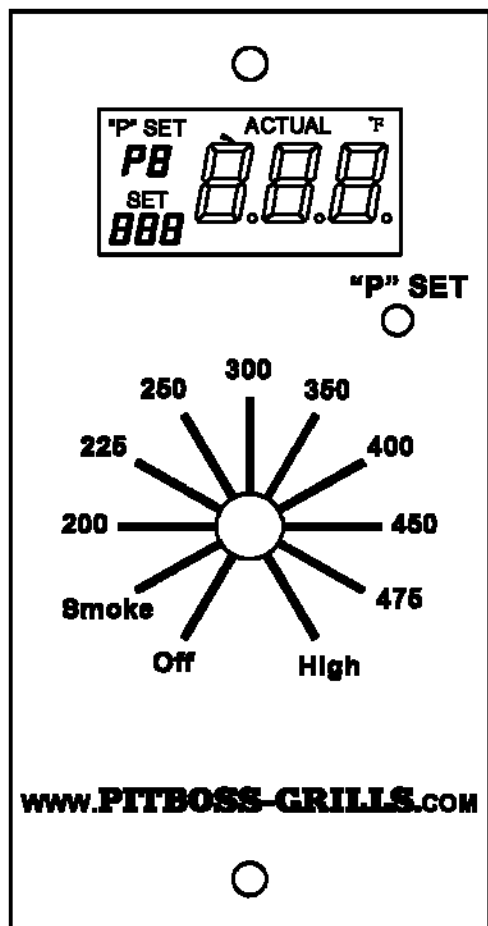

1. **Temperature Dial must be in the OFF position.**
2. Plug the power cord into a 110 V grounded electrical outlet.
3. If "ErP" is displayed, the Temperature Dial was not set to OFF. This causes an inadvertent start error, which halts the Ignition sequence. To clear the error, turn the Temperature Dial to OFF, wait 2 seconds, then set the desired cooking temperature.  
**NOTE: This safety feature keeps unintentional starts from occurring.**
4. If there are flashing dots on the LCD screen, the igniter is on. The Start-Up sequence is in progress.

### START-UP SEQUENCE

1. **Temperature Dial must be in the OFF position**
2. Plug unit into grounded electrical outlet.
3. Select the following setting on the Temperature Dial: Smoke
4. The Draft Fan and Igniter, come on. The Metal Auger Feed System begins to deliver fuel continuously for 4 minutes.
5. The Igniter will turn off after 5 minutes. At this point the Flashing Dots turn off and the grill begins to operate in its selected mode.

### SMOKE— WARM MODE - 170° F—225° F

Temperature Dial in the SMOKE position

1. LCD screen will display the current "ACTUAL" grill temperature.
2. Once the Start Up Sequence is complete, the Auger delivers fuel at a constant rate determined by the Smoke Control (P0-P7). Default Setting is P 4. (See Understanding Smoke Control for further information).
3. If Grill Temperature begins flashing, this indicates the temperature is less the 110°F, and that the fire is in risk of going out.

**NOTE:** Selecting SMOKE does not produce high volumes of visible smoke, known as "Dirty Smoke".

### HOT SMOKE— COOK MODE - 200° F - 500°F

Temperature Dial in any of the 8 Temperatures or HIGH position

1. LCD screen will display the current "ACTUAL" grill temperature.
2. Once the Start Up Sequence is complete, the Auger delivers fuel at a variable rate.
3. If Grill Temperature begins flashing, this indicates the temperature is less then 110°F, and that the fire is in risk of going out.
4. If the Grill Temperature is greater than 615°F, a flashing "ErH" is displayed indicating a high limit error and the grill will shut down.

**IMPORTANT NOTE:** If temperature dial is set on SMOKE and the grill is unable to reach your desired temperature, due to ambient temperature, humidity, wind conditions, fuel type and quality, and/or thermal characteristics of the grill, adjusting the "P" SETTING may help.  
(see Understanding "P" SET)

# Section Two: OPERATION

## PIT BOSS CONTROL

### UNDERSTANDING THE "P" SETTING

The main benefit to the P SETTING Control Button is that it allows you, the Pit Master, to fine tune your Pit Boss Pellet Grill to compensate for ambient temperatures, humidity, wind, environmental changes, pellet fuel type and quality. This ensures a World Championship Result, everytime.

When the Temperature Dial is set on **SMOKE** or **HIGH**, the Auger turns on, delivers fuel for 18 seconds, then turns off. The Off-Time is set by or adjusted by the recessed **"P" SET Push Button**, which displays a "P" setting. When the Smoke Control Button is pushed, the corresponding "P" setting is displayed on the LCD screen momentarily. There are 8 "P" settings, ranging from P0 to P7.

This aids in fine tuning your Pit Boss Pellet Grill, to your desired needs. If you like to Hot Smoke and like more natural wood flavor, then you can adjust the "P" setting, while in the SMOKE MODE, upward to give you a longer time between auger feeds. This results in a lower temperature output, which increases your cooking time, which results in a deeper "Smoke Ring" and more flavor.

'P' Setting	Auger On	Auger Off
P0	18 seconds	55 seconds
P1	18	70
P2	18	85
P3	18	100
P4	18	115
P5	18	130
P6	18	140
P7	18	150

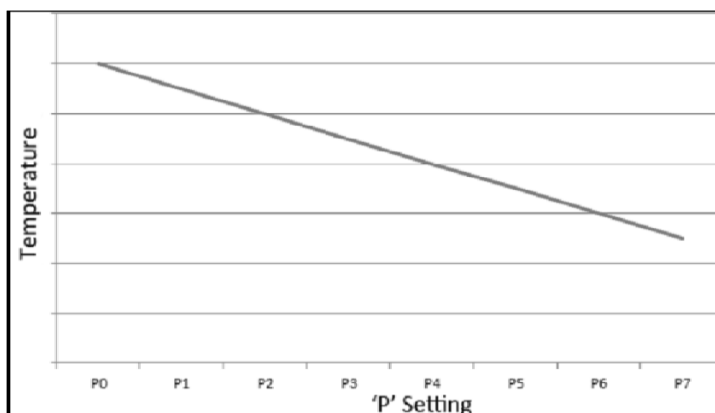

**NOTE:** Factory Default Setting is "P 4"

**INCREASING** the "P" setting **DECREASES** the Fuel Feed Rate, (heat output). This will result in LOWER grill output temperatures, lower pellet consumptions thus resulting in more smoke flavor. Care must be taken not to increase the "P" setting to high, which could result in the fire going out.

**DECREASING** the "P" setting **INCREASES** the Fuel Feed Rate, (heat output). This will result in HIGHER grill temperature output, higher pellet consumption thus higher grilling temperature. Care must be taken not to decrease the "P" setting to low, which will result in overfeeding the pellets and the production of Creosote or incomplete combustion.

**IMPORTANT:** To Change the "P" setting, use a small nylon or plastic screwdriver, or small, blunt tool to carefully depress the push button.  
DO NOT use any metal instrument, as this could cause the board to short out.



# Section Two: OPERATION

## STANDARD LIGHTING PROCEDURE

### NOTE:

*Always clean or check your burn pot before each use. This will ensure proper ignition, heat output and many continuous happy grilling experiences.*

### Automatic Start Up

1. Ensure the POWER switch is in the "OFF" position.
2. Plug the POWER CORD into a 110V grounded outlet. DO NOT break the ground end off the cord or use a non-grounded outlet or extension cord.  
NOTE: When plugged into a GFI, ensure it is at least 15 amps. Lower quality GFIs may trip, try plugging appliance into a surge protected power bar first.
3. Open the HOPPER LID. Ensure there are NO foreign objects in the hopper or AUGER feed system.  
Fill hopper with dry all natural hardwood bbq wood pellets.
4. Open the COOKING LID. **This lid MUST be open during the START-UP and COOL DOWN cycles.**
5. Turn the Temperature Dial to SMOKE.  
This activates the start up cycle. The feed system will start to turn, the igniter will begin to glow and the fan will supply air to the fire pot.  
Your grill will begin to produce smoke while the start up cycle is taking place.  
The pellets have ignited once the smoke has cleared. To confirm, with your cooking lid still open, you will hear a torchy roar and begin to feel some heat being produced.
6. Close the lid. Turn the Temperature Dial to HIGH, to allow the unit to preheat for approximately 15 to 20 minutes.

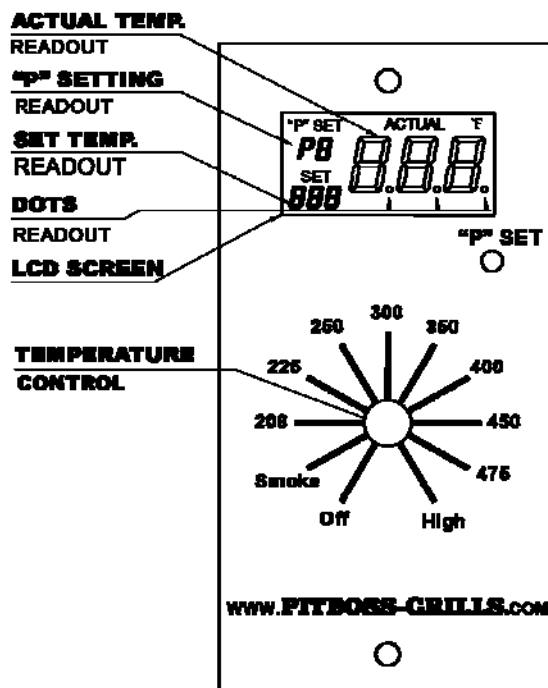

**CAUTION:** If excessive flame is visible, i.e the flavor plate is glowing red, turn the feed control down.

7. After the pre-heating is complete, you are now ready to enjoy the pellet grill advantage. Remember that lower temperatures produce more flavor and less chance of flare-ups.

**NOTE:** Different wood pellets will produce different temperatures; as well the outside temperature and weather conditions will also affect your cooking temperatures.  
The settings and read outs on the control and thermometers are APPROXIMATE.

### IF GRILL FAILS TO IGNITE:

1. Turn the Temperature Dial to OFF. Open the lid, remove the Cooking Grids and Flame Broiler.
2. Remove all unburned pellets and ash from the Fire Pot.  
DO NOT touch the Igniter. This item gets extremely HOT and will cause burns.
3. When all cleaned, turn Temperature Dial to SMOKE. Check the following:
  - A. Visually confirm the Igniter is working, by placing your hand above the burn pot.
  - B. Visually confirm Pellets are dropping in the Fire Pot from Auger.
  - C. Confirm the Fan is working.
4. If one or all of the above are not working, see the trouble shooting section or contact Customer Service. 1-877-303-3134

# Section Two: OPERATION

## MANUAL LIGHTING PROCEDURE

**IF FOR ANY REASON YOUR ELECTRIC IGNITER FAILS, YOU CAN START YOUR GRILL USING THIS MANUAL METHOD.**

**NOTE:**

*Always clean or check your burn pot before each use.* This will ensure proper ignition, heat output and many continuous happy grilling experiences.

### Manual Start Up

1. Ensure the Temperature Dial is in the "OFF" position.
2. Plug the POWER CORD into a 110V grounded outlet. DO NOT break the ground end off the cord or use a non-grounded outlet or extension cord.  
NOTE: When plugged into a GFI, ensure it is at least 15 amps.  
Lower quality GFI's may trip, try plugging appliance into a surge protected power bar first.
3. OPEN the HOPPER LID. Ensure there are NO foreign objects in the hopper or Auger feed system. Fill hopper with dry all natural flavored wood pellets.
4. Remove the COOKING GRIDS, FLAME BROILER to expose the BURN POT.
5. Place a generous handful of pellets into the BURN POT.
6. Squirt gelled fire starter, or other approved pellet starter, over the top of the pellets or add a small amount of solid fuel fire starter, such as those made from sawdust and wax or use wood shavings. Add a small amount of pellets over the fire starter.
7. Light the starter using a long fireplace match or long lighter.  
**WARNING: NEVER ATTEMPT TO ADD MORE STARTER INTO A FIRE THAT IS ALREADY BURNING OR INTO A HOT BURNGRATE. YOU COULD EXPERIENCE A BURN BACK AND YOU COULD GET SERIOUSLY BURNT.**
8. Allow the starter to burn for 3 to 5 minutes.
9. Quickly and carefully replace the FLAME BROILER and COOKING GRIDS.
10. Turn the Temperature Dial to SMOKE.  
This activates the start up cycle. The feed system will start to turn, and the fan will supply air to the fire pot. Your grill will begin to produce smoke while the start up cycle is taking place.
11. Turn the Temperature Dial to HIGH, to allow the unit to preheat for approximately 15 to 20 minutes.

**CAUTION: DO NOT USE ANY FLAMMABLE LIQUIDS SUCH AS GASOLINE, GASOLINE-TYPE LANTERN FUEL, KEROSENE, CHARCOAL LIGHTER FLUID, OR SIMILAR LIQUIDS TO START OR FRESHEN-UP THE FIRE! KEEP ALL SUCH LIQUIDS WELL AWAY FROM THE GRILL WHILE IT IS IN USE.**



# Section Two: OPERATION

## SHUTTING OFF YOUR GRILL

Your “Pit Boss” Pellet Grill will give you many years of flavorful service with minimum cleaning. An important step is allowing the grill and cooking grids to “Self Clean” by running the grill on HIGH temperature for 5—10 minutes after each use.

When finished cooking on your grill, turn the Temperature Dial to HIGH. Let your grill run for 5 to 10 minutes to go through its normal cleaning method. If you have been preparing meats that are extra greasy, it is a good practice to allow the grill to burn for an extra 10 to 20 minutes. This will reduce the chances of “Flare-Up” while preparing your next savory meal.

When complete, simply turn the Temperature Dial to the OFF position and OPEN the lid of your grill. Your grill will begin its automatic “Shut Down” procedure. The Auger system will stop feeding fuel, the flame will burn itself out, and the combustion / cooling fan will continue to run for a 2 minute period. When this procedure is complete, the FAN will turn off.

## GRILL MAINTENANCE—After Cooking

There are two extremes when it comes to keeping the grill clean. Those that must spit and shine the entire grill, inside and out, after every use, and those whom are convinced that cleaning only takes away from that barbeque flavor. One simple rule: **Everything In Moderation**

### 1. Grease

- Always be sure the grease catch area is clean and free of debris.
- Check your Grease Bucket. Clean it out as necessary. Keep in mind the type of cooking you do.
- Periodically clean the grease out of the grease catch areas, the grease drain tube and the interior surfaces of the grill.
- Remove any grease or debris build-up on the Flame Broiler, as this can reduce the grease run-off and eventually lead to a unwanted flare-up.

NOTE: It is easier to clean of accumulated grease when the grill is warm.  
BE CAREFUL NOT TO BURN YOURSELF.

### 2. Outside surfaces.

**Paint and maintaining painted surfaces are not covered under warranty. This is part of the general maintenance and upkeep.**

- DO NOT use oven cleaner, abrasive cleansers or abrasive cleaning pads on the outside grill surfaces. Use warm soapy water to cut the grease.
- Wipe your grill down with a warm, soapy damp cloth after each use.
- Using a cover to protect your grill is highly recommended!

### 3. Inside surfaces

- Using a long handle grill cleaning brush, brass or soft metal, remove any food or build-up from the cooking grids, while they are still warm.
- Two or three times a year, remove the cooking grids and flame broiler and clean in and around the burn pot area. A shop-vac is handy for this chore. Make sure the grill is COMPLETELY COLD.



# Section Three: TIPS & TECHNIQUES

## 100% Natural Hardwood Wood Pellets



They are no thicker than the eraser on the end of a pencil. People who see them for the first time think they look like rabbit food, but there is nothing small about the heat energy or flavor in a wood pellet. These clean burning wood pellets generate about 8200 BTU's per pound with very little ash (.3lb/40lb bag) and low moisture content (5-7%) and are "carbon neutral".

Barbeque wood pellets are produced in the same matter as wood pellet fuel is produced for home heating, PFI Standard Premium Grade (see [pelletheat.org](http://pelletheat.org)). Pure raw material (sawdust) is pulverized with a hammer-mill and the material is pushed through a die with pressure. As the pellet is forced through the die it is sheared off at a specific maximum length, cooled, screened, vacuumed, and then bagged into 20 or 40 lb. bags.

BBQ wood pellets differ from smoking pellets, used in gas or propane grills, in that most are a combination of the main wood type and a neutral wood type. This is done because of the more intense flavor being generated when using pellets as your main fuel.

### Flavor Guide Lines

Check with your local dealer for flavors available in your area.

	Beef	Buffalo	Lamb	Pork	Poultry	Fish	Vegies	Baking
Hickory	X	X		X	X	X		
Mesquite	X	X		X	X	X		
Alder	X	X	X	X	X	X	X	X
Apple				X	X	X		X
Cherry	X	X	X	X	X	X		X
Competition	X	X	X	X	X	X	X	X

### Wisconsin Hickory Blend

Rich, smoky bacon like flavor. Considered the "Kings of the Woods"

### Georgia Pecan Blend

Southeast delicate flavor. Smokey, Bacon-like flavor. Similar to Hickory but not as strong.

### Texas Mesquite Blend

Strong, tangy, spicy flavor. Think Tex-Mex cuisine.

### New England Apple Blend

Smoky, mild sweetness flavor. Highly recommended for baking.

### Washington Alder Blend

100% Pacific Northwest Mild, neutral, hint of sweetness, Used for over 100 years with salmon.

### Pennsylvania Cherry Blend

Slightly sweet but also tart. Gives a rosy tint to light meats.

### Competition Blend

Maple. Hickory. Cherry

Perfect blend of sweet, savory and tart. Used by many professional "Pitmasters".

### Tennessee Whiskey Barrel Blend

Oak. Whiskey Barrel

Strong, sweet smoke with aromatic tang. Perfect for red meats.



**TIP** Always store your pellets in a dry area. Avoid any contact or exposure to moisture. This will cause the pellets to absorb the moisture and will result in lower heat output or cause the pellets to swell and break apart. Use a moisture proof re-sealable tub or bucket.

# Section Three: TIPS & TECHNIQUES

## COLD WEATHER COOKING



Just because the bright coloured leaves are gone and the golf clubs are put away for another season, doesn't mean you have to stop barbecuing. The clean crisp fresh air, the heavenly aroma of flavoured wood pellets and food cooking, may be just what the doctor ordered to cure those winter blahs. Holiday grilling also frees up your oven space for other important menu items. Following are a few suggestions on how to enjoy your grill throughout those cooler months:

**Remember:** Because of the cooler temperatures your SMOKE mode may fail. Use the LOWER COOKING temperatures to achieve the same results. KEEP WATCH !!

**ORGANIZE** – Get everything you require ready in the kitchen before you head out to the great outdoors. Put what you need on a tray, bundle up tight, and “get it done!” During the winter move your grill to an area that is out of the wind and cold. Check local bylaws regarding the proximity of your grill in relation to your home and/or other structures.

**Caution: Never grill in an unventilated area!**

To help you keep track of the outside temperature, you should place an outdoor thermometer close to your cooking area. This will help in determine how long it will take to cook your food.

You may want to keep a log or little written history on what you cooked, the temperature outside, and the results. This will help latter down the road to help you determine what to cook and how long it will take.

When cooking in cold weather, it is better to increase your pre-heating time by at least 20 minutes.

Avoid lifting the grill lid any more than necessary. Cold gusts of wind can completely cool your grill temperature. Be flexible with your serving time; add about 10 – 15 minutes extra cooking time each time you open the lid.

As always, use a meat thermometer to determine the internal temperature of your foods.

Because the nights come sooner in the colder months, it is a good ideal to work in a lighted area or to have a light or flashlight close by.

Have a heated platter and maybe a cover ready to help keep your food warm while making the trip back inside.

Some of your better foods for winter cooking are those that require little attention, like roasts, whole chicken, ribs, and turkey. Make you meal preparation even easier by adding vegetables and potatoes.

## HOT WEATHER COOKING

Following are a few tips on hot weather cooking. As it gets hotter outside, not only will the cooking times of your food decrease but the cooking time on yourself decreases. Proper dress is a must. Shorts, T-shirt, shoes, hat, apron and a generous slab of suntan lotion go without saying. Don't forget the big tall cool drink; we don't want the chef to become dehydrated.



**ORGANIZE** – You don't have to serve a huge seven-course meal. You don't want to be cleaning your entire kitchen after every meal. Timing is everything to cooking outside and remember practise does make perfect. So practise lots and EXPERIMENT!!!

Adjust your cooking temperatures downward. This helps to avoid those unwanted flare-ups.

As always, use a meat thermometer to determine the internal temperature of your foods. This helps in preventing your meat from over cooking and drying out.

Even in hot weather, it is still better to cook with the lid of your grill down.

You can keep foods hot by wrapping them in foil and placing them in an insulated cooler. Stuff crumpled up newspaper around the foil and this will keep food hot for a good 3 to 4 hours.

Try to keep your menu on the lighter side. So you can enjoy the warm temperatures and quality family times.

# Section Three: TIPS & TECHNIQUES

Here are some helpful tips and techniques passed on to us from many Pit Boss Grill owners, our staff, families and lots and lots of practise:

## **TIP:**

*Sugar based sauces are best applied near the end of cooking to prevent burning.*

- Before preheating the grill, make sure it is safe, clean and hygienic.
- **Always preheat your grill before cooking.** After ignition has taken place, turn your control knob to the HIGH setting, be sure the lid is closed and allow the grill to heat for at least 10 – 15 minutes or until the thermometer registers over 350° F.
- When going from a HIGH temperature to a LOW temperature, left the lid and leave it open until the ACTUAL temperature is close to your DESIRED temperature. This speeds up the process and ensures the fire will not go out.
- Wipe off all stainless steel surfaces before preheating. Dirt and food stains will cook into the surface.
- **“Mise en Place”.** Three words that are essential for master grilling. The “Mise” refers to the basic setup of ingredients and equipment you need at grill side before you start cooking.
- Ensure the ash/drip pan is clean and free from any debris and fat build-up.
- Always check your pellet fuel hopper for debris and to ensure that you do not run out of pellets before finishing. Use a shop vac to clean out any sawdust build-up.
- To prevent foods from sticking, you can brush or rub cooking oil on the cooking grids. If using a vegetable spray use it only before lighting the burn pot. Never spray the grill while there is fire in the burn pot.
- Sear meats and cook with the lid down for perfectly grilled food every time.
- All Pit Boss Grills are designed to allow even fan forced heat circulation, so foods cook evenly on all sides. Leave at least 1” of clearance between the food and the hood for proper heat flow.
- **Grilling times in recipes are based on 70°F (20°C) weather and little to no wind. Allow more time on cold, windy days, or even for higher altitudes. Allow less time for warmer weather.**
- To get better smoke penetration into your meats, go SLOW and LOW. Meat will close its fibres after it reaches a temperature of 120°F.
- Foods on a crowded cooking grate will require more cooking time than just a few foods.
- Foods grilled in containers, such as baked beans, will require more time if grilled in a deep casserole rather than a shallow baking pan.
- Use long-handled tongs for turning all meats and spatulas for turning burgers and fish. Do not use a fork for turning, as it will pierce the meat allowing the flavourful juices to escape.
- Misting or Mopping are great ways to keep meat from drying out when going SLOW and LOW. A mixture of 50/50 apple juice (not cider) and water keeps the meat moist and gives it great color.
- **A smart investment to purchase would be a BBQ Mat. Due to food handling accidents and cooking styles, a mat would protect that expensive deck or patio stone from the possibility of grease stains or accidental spills.**



# Section Three: TIPS & TECHNIQUES

## FOOD SAFETY TIPS AND TECHNIQUES

### 3

#### Three Basic Rules for Food Safety

1. Keep everything in the kitchen and cooking area clean.
2. Keep hot foods hot (above 140°F)
3. Keep cold foods cold (below 37°F)

We want you to enjoy healthy and safe grill cooking, so following are some hints for basic barbecue hygiene:

- Wash hands thoroughly with hot, soapy water before starting any meal preparation and after handling fresh meat, fish and poultry.
- Use a different platter and utensils for the cooked meat than the ones you used to prepare or transport the raw meat out to the grill. This will prevent cross contamination of bacteria.
- Use a different utensil for each marinade or basting sauce to prevent cross contamination.
- Do not leave hot foods out of refrigeration for more than two hours.
- Cooked foods and salads should not be left out in the heat for more than an hour. Fill a deep tray or casserole dish with ice to keep salads cool and safe.
- Do not defrost meat at room temperature or on a counter top. Thaw under refrigeration.
- Marinate meat in the refrigerator. Bacteria are living organisms that grow and multiply rapidly in warm, moist foods.
- A marinade should never be saved to use at a later day. If you are going to use it to serve with your meat, be sure to bring it to a boil before serving.
- Always use a meat thermometer to determine the internal temperature of the foods you are cooking. **Wood smoke turns meat and poultry pink. The pink band is a smoke ring and is highly prized by the true "Pit Masters".**
- It's a good idea to put grilled food onto a heated platter, to help keep the food warm. Steaks benefit from resting for several minutes before serving. It allows those delicious juices that were driven to the surface by heat to ease back to the center.



# Section Four: TROUBLE SHOOTING

Proper cleaning, maintenance and the use of clean, dry, quality fuel will prevent common grill operational problems. However, when your Pit Boss Wood Pellet Grill is simply operating poorly, or not at all, the following trouble shooting tips may be helpful.

The following is not an exhaustive list. For further details or updated information, please check: our website [www.pitboss-grills.com](http://www.pitboss-grills.com) and click on “Customer Support”: contact your **local authorized dealer**: or contact **Dansons Customer Service**, toll free at **1-877-303-3134, Monday to Friday, 8 am to 5 pm Mountain Time**.



**DO NOT RETURN** the appliance without calling Dansons Customer Service for assistance.



**WARNING:** Always disconnect the electrical cord prior to opening the inspection plate of your grill for any inspection, cleaning, maintenance or service work.



**NEVER** perform any inspection, cleaning, maintenance or service on a **HOT GRILL**.

Problem	Cause	Solution
<b>LCD Screen Will Not Light UP</b>	Grill is not properly plugged in	Ensure the Temperature Dial is in the OFF position. Ensure all wire connections are firmly connected Ensure grill is plugged into a working GFCI outlet
	The circuit board fuse has been tripped	Fuse (5 amp.) must be manually replaced. (see board diagram at the end of this section)
	The GFI outlet has been tripped	Ensure all wire connections are firmly connected and dry Ensure GFCI is minimum 15 amp service. Ensure you are NOT using over a 25' extension cord.
<b>“ErH” Error Message</b>	The grill has overheated, possibly due to grease fire or excess fuel.	Turn the grill OFF and allow to cool. Clean grill interior, remove excess pellets, and confirm positioning of all component parts. To CLEAR the error - Turn Temperature Dial to OFF. OPEN the lid, wait 3 or 4 minutes, then select desired temperature.
<b>“ErR” Error Message</b>	Temperature probe wire not making connection	Ensure probe wire is connected correctly to control Confirm wire connections and check for any damage
<b>“ErP” Error Message</b>	Temperature Dial was not in the OFF position when grill connected to AC power.	Turn Temperature Dial to OFF, wait 2 minutes, then select desired temperature. Safety feature prevents an inadvertent start.
	Power Outage occurred while the grill was operating	Turn temperature dial to Off, wait 2 minutes, then select Desired temperature.
<b>Flashing Temperature on LCD Screen</b>	SMOKE Mode If grill temperature below 110°F	This is NOT an ERROR that effects the grill. USED to show that there is some risk that the fire could go out. Check the hopper for sufficient fuel or blockage.
	COOK Mode If grill temperature below 150°F	Check burn grate and pot for ash build-up or obstructions. Check fan to confirm operation and speed. Check auger motor to confirm operation.
<b>Flashing Dots on LCD Screen</b>	The Igniter is ON	This is NOT and ERROR that effects the grill. Used to show that the unit is in Start-Up mode.



## Section Four: TROUBLE SHOOTING

Problem	Cause	Solution
<b>Grill will NOT Start</b>	Power	Ensure unit is plugged in. Verify there is power at the electrical outlet. Check and reset the Ground Fault Interrupter, if necessary. If igniter not working, check 5 amp fuse found on the back of the control. Replace if necessary.
	Temperature Dial	Ensure Temperature Dial is in OFF position. Turn Temperature Dial to SMOKE. LCD SCREEN will light up,
	Igniter	Remove Cooking Grids and Flavor/Grease Tray. Turn unit on and visually inspect the igniter. <b>START UNIT USING MANUAL START INSTRUCTIONS.</b> Call Customer Service for replacement part.
	Auger Motor	Remove Cooking Grids and Flavor/Grease Tray. Turn unit on and visually inspect the auger feed. Remove Control Board and inspect the wires and connections. If not working, Call Customer Service for replacement Auger motor
	Control Board	Remove Control Board and inspect the wires and connections. If not working, Call Customer Service for replacement Pit Boss Control Board.
<b>Grill Temperature when set at SMOKE is too high</b>	"P" Setting is to LOW	Turn Temperature Dial to SMOKE, Pushing the "P" SETTING Button to INCREASE the "P" setting.
<b>Unexpected Grill Temperature is Displayed</b>	Grill is exposed to high ambient temperature and direct sun.	The interior temperature has reach or gone over 130°F. It will not harm the unit. Place unit in shaded area. Prop the lid open to reduce inside temperature.
<b>Grill will not achieve or maintain stable temperature</b>	Insufficient air flow through burn pot	Check the burn pot for ash build-up or obstructions Check the fan for proper operation; that it is working, that the air intake is not blocked and that there is no blockage in the auger tube. Perform a quick test. Remove cooking grids and flavor / grease plate. Ensure all the above has been done, start the grill, set temperature to pre-heat and wait for 10 minutes. Check that the flame produced is bright and vibrant.
	Insufficient or poor fuel	Check the hopper for sufficient fuel. Check fuel for size, dampness and amount of sawdust.
	Grill Temperature Probe	Check and clean the temperature probe
	Control Settings	Ensure "P" setting is correct
<b>Grill produces excess or discolored smoke</b>	Excess grease build-up or general cleaning	Check and clean the interior grilling area. It is a good practice to clean and do a controlled burn off of the hidden excess grease after each large cooking of tasty greasy foods.
	Wood pellet quality	Check and clear the hopper and burn pot of moist pellets, replacing them with fresh dry pellets.
	Burn Pot	Check for build-up of fuel in the burn pot
<b>Frequent Flare-ups</b>	Cooking temperature	Slow and Low is the way to go. Grease does have a flash point, keep the temperature under 350° F when cooking highly greasy food.



# Section Four: TROUBLE SHOOTING

## PIT BOSS Digital Temperature Control

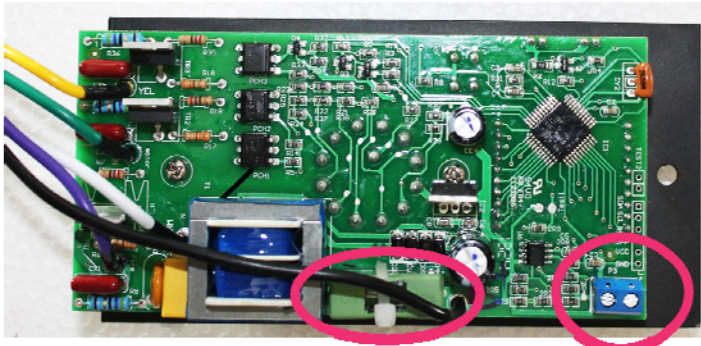

**5 amp 120 Volt  
Fast Blow Cartridge  
Fuse Housing**

**Grill Probe  
Termination**

The Pit Boss Digital Temperature Control system is an intricate and valuable piece of technology.

For protection from power surges and electrical shorts, the control utilizes a 5 amp, 120 Volt Fast—Blow Fuse.

It is recommended to unplug your grill from any electrical connection, when not in use. This will help to protect from electrical surges and storms.

## Pit Boss Wire Diagram

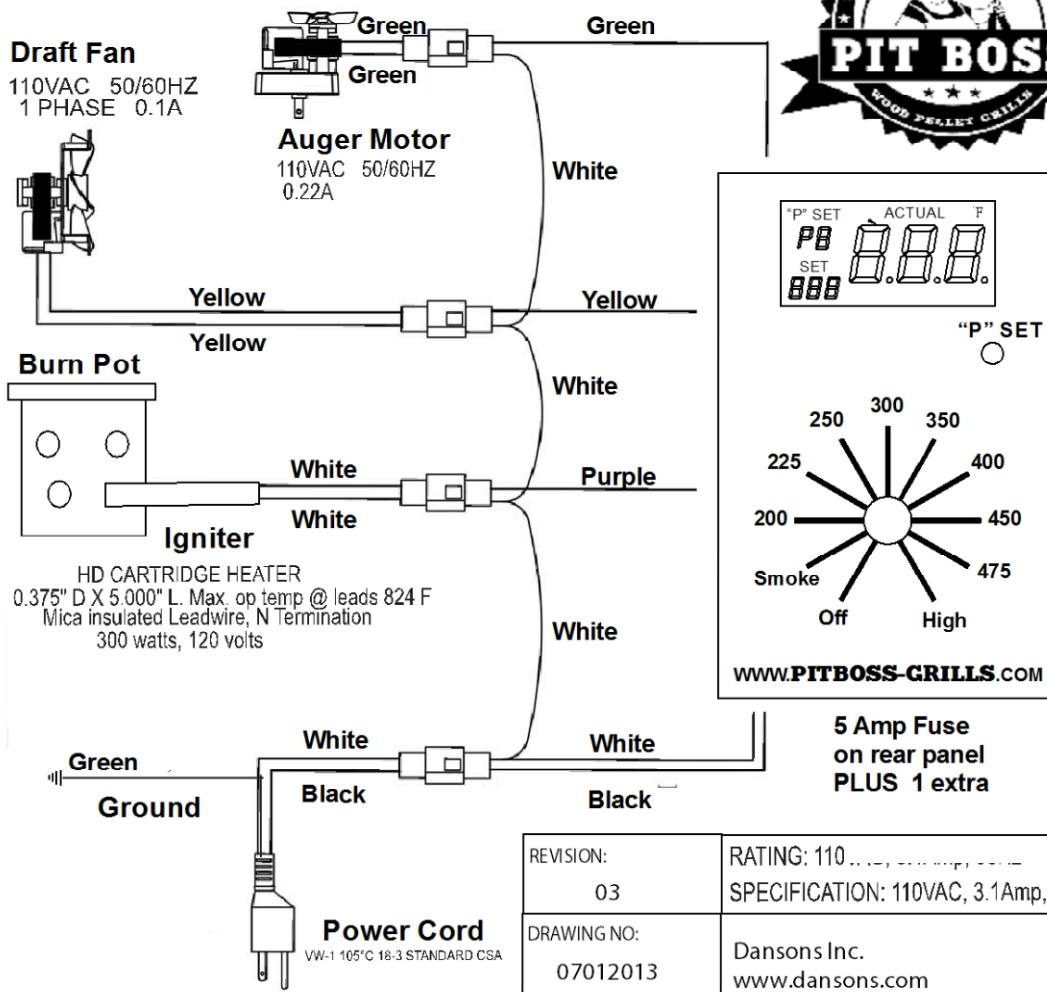

REVISION: 03	RATING: 110... SPECIFICATION: 110VAC, 3.1Amp, 60Hz
DRAWING NO: 07012013	Dansons Inc. www.dansons.com

# Section Four: TROUBLE SHOOTING

## PARTS LIST

### REPLACEMENT ITEMS

Item	Part #	Description	QTY
1.	76122	Upper Rack	1
2.	74035	Cooking Grids	2 or 3
3.	74516	Flame Broiler—main	
4.		Flame Broiler—slide	
5.	74322	Handle—Chrome	1
6.	74228	Bezel, (decorative washer)	2
7.		Barrel & Hopper Assembly	1
8.	74321	Leg w/ Wheel axle (right hand side end)	2
9.		Bottom Shelf	1
	74347	820FB—Open Grid	
	74348	820Deluxe—solid	
10.	74086	Metal Wheel	2
11 a.	74322	Back Leg (hopper end)	1
11 b.	74323	Front Leg w/bottle opener (hopper end) * Deluxe models only	1
12.	74400	Grease Bucket	1
13.		Handle—Side (tray holder)	1
	74222	820Deluxe— Stainless	
14.	74080	Smoke Stack	1
15.	74801	Smoke Stack—Gasket	1
16.	74402	Dome Thermometer	1
17.	74403	Lid Stopper	1
18.	74328	Bottle Opener (820Deluxe only)	1
19.	74223	Serving Tray (820DG only)	1

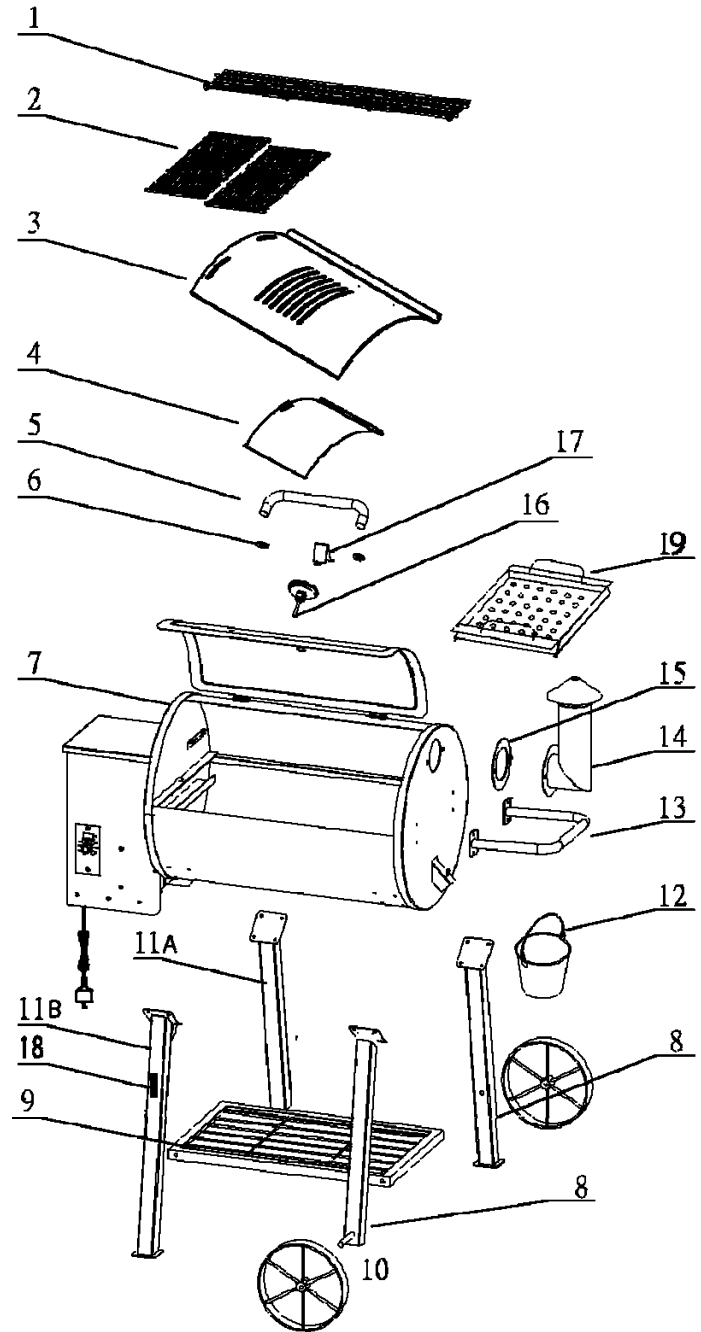

# Section Four: TROUBLE SHOOTING

## PARTS LIST

### Pellet Feed System

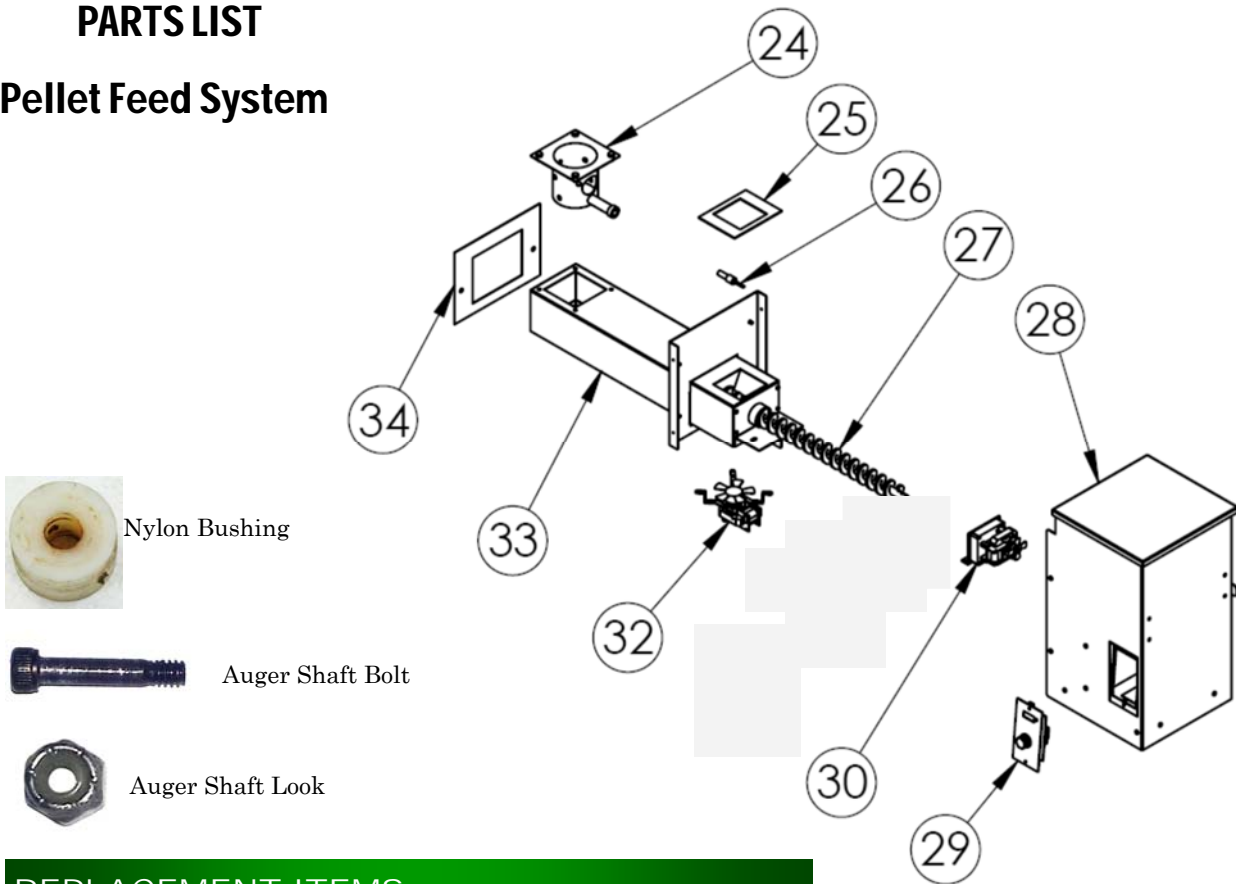

## REPLACEMENT ITEMS

Part No.	Description
24 74254	Fire Pot
25 74251	Hopper / Auger Box Gasket
26 70112	Igniter—Hot Rod
27 74070	Auger Flighting
74072	Auger Shaft Bolt 7/8" L x 9/64" thick
74073	Auger Motor Shaft Lock Nut #32 thread
28 76135	Hopper Box— Housing only
29 70120	Pit Boss Electronic Oven Control
30 70102	Auger Motor
31 74077	Nylon Bushing
32 70133	Combustion Fan
33 74069	Auger Box - Housing only
34 74250	Hopper Assembly / Grill Body Gasket
35 70124	Grill Probe—RTD



# Section Five: GRILL RECEIPES

## COOK TIME GUIDELINES

The following cooking guidelines are just that “Guidelines”, and are in no way the only way to cook. For best results and to become a true “Pit Master”, keep a record of what you cooked, at what temperature you cooked; how long you cooked for; what seasoning you used; what flavor of pellets you used; and the results. Then adjust to your taste for the next time. Most “Pit Masters” have very thick records. Practice makes perfect.

**TIP! For best results** always allow for “Resting Time”. This allows the natural juices to migrate back into the meat fiber, giving a much juicer, flavorful cut. Resting times can be as little as 3 minutes and up to 60 minutes, depending on the size of the protein. Use foil wrap to form a “tent” over the meat.

Style of Cooking	Hot Smoking	Roast	Baking (Medium)	Grill / Bake (Medium / High)	Sear (High)
Temperature Ranges	200-275°F	275-325°F	325-375°F	400-450°F	450-500°F

The style of cooking used will give you different results. Hot Smoking means longer cooking times but results in more natural wood flavor or “Pink Ring” as it is called by “Pit Masters”. Higher cooking temperature thus shorter cooking times result in less smoke flavor. Adjust the following Heat suggestions to fit your taste.

<b>BEEF</b>	Size	Heat	Approximate Cooking Time
			Internal Temp. Rare - 140°F Medium - 150°F Well Done - 160°F
Steak (New York, Porterhouse, Rib-eye, Sirloin, T- bone, or Tenderloin)	¾” 1” 1 ½” 2”	High	Sear 8 – 10 minutes Sear 10 –12 minutes Sear 10 minutes, grill 8 –10 minutes Sear 10 minutes, grill 10 – 14 minutes
Skirt Steak	¼” – ½”	High	5 – 7 minutes
Flank Steak	1-1 ½lbs., ¾”	Med	Sear 4 minutes, grill 8 – 10 minutes
Kabob	1 – 1 ½” cubes	Med	10 – 12 minutes
Tenderloin, whole	3 ½ - 4 lbs.	High/Med	Sear 10 minutes, grill 15 – 30 minutes
Ground Beef Patty	¾”	High/Med	Sear 4 minutes, grill 4 – 6 minutes
Rib-eye Roast, boneless	5 – 6 lbs.	Med	1 ½ -2 hours
Tri-tip Roast	2 – 2 ½ lbs.	High/Med	Sear 10 minutes, grill 20 – 30 minutes
Rib Roast	12 –14 lbs.	Med	2 ½ - 2 ¾ hours
Veal Loin Chop	1”		10 – 12 minutes Direct/Medium
Brisket		Hot Smoke	180°F to 190°F Internal Temp.

<b>PORK</b>	Thickness/Weight	Precooked to Reheat 140°F	Medium 140—150°F	Well Done 160°F
Ham – Fully Cooked - Boneless Portion	1”	12 minutes	-----	-----
	3 – 4 lbs.	50 minutes–1 hour	-----	-----
	4 – 6 lbs.	1 – 2 hours	-----	-----
	5 – 8 lbs.	1 – 2 ½ hours	-----	-----
Smoked Picnic Whole, bone-in	10 – 12 lbs.	2 – 2 ¾ hours	-----	-----
Loin Roast	3 – 4 lbs.	-----	1 – 2 hours	2 – 3 hours
Rib Crown Roast	4 – 6 lbs.	-----	1 ½ - 2 hours	2 – 3 hours
Chop (loin, rib)	¾” - 1”		10—12 mins.	
	1 ¼” - 1 ½”		14—18 mins.	
Tenderloin	¾ - 1 lbs.	-----	20 – 30 minutes	30 – 45 minutes
Loin Roast, boneless	3 – 5 lbs.	-----	1 ¼ - 1 ¾ hours	1 ¾ - 2 ½ hours
Boston Butt (Pork Shoulder) - Fall Off The Bone	8 - 10 lbs.	-----	-----	200-210°F Internal Temp.

# Section Five: GRILL RECEIPES

## A "CLASSIC" BRISKET

Makes 4 – 6 servings

A whole beef brisket weighs 16 to 18 pounds and has three separate parts: the cap, the point, and the flat. Use the "Flat" section as it is lean, compact and produces handsome slices when you carve it.

- 1 5 to 8 lbs. Beef Brisket – "Flat" portion with a layer of fat at least ¼" thick
- 1 Bottle Prepared Yellow Mustard Seasoning— such as "Sweet Heat" or "Key Lime Jerk"

### Mop

- 1 Bottle of Chili Sauce
- 1 Package Dry Onion Soup Mix
- 1 Can Coca-Cola® Classic
- ½ Teaspoon Black Pepper



**Suggested Pit Boss Wood Pellet Flavour:** Hickory, Competition Blend

Lay out a large piece of plastic wrap on your working station. Large enough to encase the brisket.

Using a sharp knife "score" the underside of the brisket, one time against the grain. This will aid in slicing the finished brisket, against the grain resulting in a tender, melt-in-your-mouth cut. The underside is the non-fat cap side.

Slather on a generous amount of prepared mustard. Rub lightly onto the entire area.

Sprinkle a generous amount of seasoning onto the mustard, then again light rub into the meat.

Flip the brisket over and repeat the process.

Wrap the prepared brisket in the plastic wrap and refrigerate 2—4 hours or overnight.

**Preheat barbecue then reduce to SMOKE or LOW. (180 to 225°F)**

Place the brisket, fat side up, in the center of the preheated grill. Close the grill lid. Slow Cook until tender, about 10—12 hours. (time will depend on size of brisket and heat of grill).

Baste the brisket with the mop mixture at least one every ½ hour for the first 3 hours.

Continue the Slow Cooking process until the internal temperature reaches 140°F to 150°F.

Remove the brisket from the grill. Place in a foil pouch, using a double wrap of aluminum foil. Before sealing the pouch tight, pour approximately a ¼ cup of Coca-Cola over the entire rack.

Turn grill up to 350°F and lay foil pouch carefully on the grill.

Steam for 1 to 1 ½ hours or the internal temperature reaches 170°F.

Test for doneness, use an instant-read meat thermometer: The brisket should be firm but be able to pull the meat apart with your fingers.

Transfer the finished brisket to a cooking board and let rest for 10 minutes. Thinly slice across the grain.

## SAUSAGE WITH MANGO AND FENNEL CHUTNEY

Makes 4 – 6 servings

- 2 Mangoes (finely chopped)
- 2 Pounds Italian Sausage
- 2 Teaspoons Fresh Parsley (minced)
- 1 Tablespoon Red Pepper (diced)
- 2 Teaspoons Honey
- ½ Red Onion (diced)
- ½ Bulb Fennel (diced)
- 1 Teaspoon Lime Juice
- Pinch Salt

**Suggested Pit Boss Wood Pellet Flavour:** Hickory or Competition Blend

**Preheat barbecue then reduce to LOW-MEDIUM (180 TO 225°F)**

Prepare the barbecue by preheating on high and brushing grids with oil. Place sausage on the grill and reduce heat. Cook at low setting approximately 10 minutes per side.

Combine remaining ingredients for chutney. Chill until ready to serve. Slice the grilled sausage on the diagonal and serve with chutney.



## BLUE CHEESE STEAK

Makes 4 servings

4		T-bone Steaks or Rib –Eye (1" thick; about 10-12 ounces each)
4	Ounces	Crumbled Blue Cheese
¼	Cup	Green Onions and Tops (thinly sliced)

**Suggested Pit Boss Wood Pellet Flavour:** Hickory, Competition Blend or Whiskey Barrel



**Preheat barbecue on PREHEAT .**

Trim excess fat from the beefsteaks and discard. Brush cast iron grate with olive oil. Place steaks on cooking grating. Sear on each side while still on PREHEAT. See diagram in the Cooking Guide section for the perfect “steak house” look.

Reduce heat to Medium, turn the steaks for final time, combine cheese and onions and sprinkle over steaks, cover and grill until desired doneness. Check doneness by cutting a slit in meat near the bone.

**Variation: “Reverse Sear” method.** Give your steaks a little lovin by giving them a gentle rub of **Louisiana Grills Chop Rub**. Turn grill to smoke mode, then place steaks unto the grids. Smoke at 180 degrees for desired taste, 5 to 15 minutes. Then turn grill up to 500°F and sear steaks to your liking.

**TIP** You can make use of the ever growing selection of commercially prepared seasons, rubs or sauces, but with the flavour produced with a wood pellet grill you will find you may reduce or not use any. Give it a try, you will taste the difference!

## BBQ RIBS

Makes 4 – 6 servings

3-4	Pounds	Ribs – Meaty pork spareribs or loin back ribs
3	Tablespoons	Oil
1	Tablespoon	Salt
½	Teaspoon	Red Pepper
½	Teaspoon	Black Pepper
2	Chopped	Onions
2	Tablespoons	Vinegar
2	Tablespoons	Worcestershire Sauce
¾	Cup	Coca-Cola
1	Teaspoon	Paprika
1	Teaspoon	Chilli Powder



**Suggested Pit Boss Wood Pellet Flavour:** Hickory, Apple or Competition Blend

**Preheat barbecue then reduce to SMOKE-LOW. (180-225°F)**

Prepare ribs by peeling off tough layer of skin on back side, commonly known as “the flavour blocker”..

Sprinkle the ribs with salt and pepper. (Can also use **Louisiana Grills Sweet Rib Rub**)

Space ribs out evenly over the cooking surface. Smoke for 3 to 4 hours.

Mix the remaining ingredients to make a finishing sauce. Place in a saucepan and bring to a boil for at least 5 minutes to thicken. Season to taste.

Remove the ribs from the grill. Place each rack in a foil pouch, using a double wrap of aluminum foil. Before sealing the pouch tight, pour approximately a ¼ cup of Coca-Cola over the entire rack.

Turn grill up to 350°F and lay foil pouches carefully on the grill. Steam for 1½ to 2 hours, till the meat has exposed the rib ends and meat is tender. Ribs should be one-bite off the bone.

Turn grill up to HIGH (500°F). Place ribs back on the grill and baste with sauce. Baste or mop sauce on both sides of the ribs till the sauce is caramelized and the ribs are sticky, messy good.

**Variation: “Memphis Dry” method.** After turning grill to HIGH (500°F), place ribs back on the grill, season with more dry rub, and sear to produce “Steak House” markings. Allow to rest, then cut to size.

## MOM'S JUICY HAMBURGERS

Makes 4 – 6 servings

2	Lbs.	Ground Beef or Buffalo
3	Tsp.	Louisiana Grills "Chop House Steak Rub"
2	Whole	Eggs, room temperature
2	Cups	Dried, Fine Bread Crumbs, or Crushed Soda Crackers
½	Cup	Prepared BBQ Sauce
6-8		Hamburger or Kaiser Buns
2	Tablespoons	Melted Butter

**Suggested Pit Boss Wood Pellet Flavour:** Hickory or Competition Blend

**Preheat barbecue on High then leave or reduce slightly (400—500°F)**

Combine all the ingredients in a mixing bowl and blend together. Don't forget to wash your hands after mixing rare meat. Divide the meat into portions, and gently shape into patties similar in shape and size to the buns you will be serving. Keep the patties about ¾" thick.

Oil the cooking grids generously with olive oil to avoid sticking. Place patties on the grill, and reduce heat to medium/high.

Grill approximately 6 minutes per side, taking care not to press down on the meat. Test for doneness, use an instant-read meat thermometer: the internal temperature should be above 160°F. Remember the meat will turn pink on the outside due to the savory smoke.

Brush the buns with the melted butter and toast them on the grill, 30 seconds to 1 minute.

**VARIATION:** Add your favourite cheese, slices or crumbled, during the last 2 minutes of grilling.

**TIP** Most people are watching their fat intake these days, but in the case of hamburgers, you will find a slightly fattier meat makes for a moister burger. For a super tasting and lean alternative try ground buffalo..

## SIRLOIN STEAK WITH SWEET ONION AND PEPPERS

Makes 4 servings

2	1 lb.	Bones Top Sirloin Steak, 1" thick, cut into 4 pcs
2	Teaspoons	Seasoning Salt or Louisiana Grills Mesquite favor rub
5	Cups	Sweet Onion, coursed chopped
2	Peppers	Red, Yellow, Orange or Green Bell Pepper, coursed chopped
4	Teaspoons	Soy Sauce
4	Teaspoons	Virgin Olive Oil

**Suggested Pit Boss Wood Pellet Flavour:** Hickory, Mesquite or Whiskey Barrel

**Preheat barbecue on HIGH then leave on HIGH. (425°F+)**

Sprinkle both sides of the steaks with the seasoning salt or rub. Cover and refrigerate at least 1 hour.

Place onion and bell peppers on a large piece of heavy-duty foil. Drizzle with soy sauce and 2 teaspoons of olive oil; sprinkle with salt. Seal the foil packet completely. Place the packet on the grill, at medium heat for 10 – 15 minutes or until vegetables are soft and tender. (Test for doneness by poking a small sharp knife through the foil). Remove from grill but keep covered.

Oil the cooking grids generously with olive oil to avoid sticking. Place steaks on cooking grating and sear on each side while still on PREHEAT. See diagram in the Cooking Guide section for the perfect "steak house" look. Test for doneness, use an instant-read meat thermometer or cut a slit in the meat to check color.

Place steaks on serving plates and top with warm onion-pepper mixture.

## SHRIMP KABOBS WITH CURRY BUTTER

Makes 4 servings

- 2 Pounds Large shelled, deveined shrimp
- Curry Butter (see recipe below)
- Olive Oil
- Lime or Lime Wedges
- Fresh Dill or Parsley Sprigs

**Suggested Backwoods Pit Boss Pellet Flavour:** Mesquite or Competition Blend

**Preheat barbecue then reduce to 275° to 325° F**

Soak wooden skewers in water for 1 hour.

Prepare shrimp by gently pulling the shells away, and removing the vein with a paring knife.

Make curry butter. Thread shrimp on six 12" skewers, leaving space between pieces. Lightly brush or spray the shrimp with olive oil.

Grill until shrimp turn pink and are tender, 2 to 5 minutes, depending upon size (do not overcook). Turn skewers of shrimp once and brush with curry butter halfway through cooking time.

Arrange grilled shrimp on serving plate. Garnish with lime wedges and dill.

### CURRY BUTTER

- |          |             |                      |
|----------|-------------|----------------------|
| ½        | Cup         | Butter               |
| 2        | Tablespoons | Finely chopped onion |
| 1        | Teaspoon    | Snipped fresh dill   |
| 1 – 11/2 | Teaspoon    | Curry powder         |
|          | Dash        | Garlic powder        |

Melt butter in small pan over Medium-High heat. Stir in onion, dill, curry powder and garlic powder; cook 5 minutes. Makes about ½ cup. Use as a dip with any seafood.

**TIP** To skewer a peeled and deveined shrimp so that it is straight, hold it in a stretched-out position with one hand. Start at the tail end and insert a bamboo or wooden skewer into the shrimp so that it runs the full length. Keep unbending the shrimp with your fingers as you go.

## BACON BASIL SHRIMP ON A STICK

Makes 4 – 6 servings

- 24 Jumbo / Extra Large Shrimp (peeled and deveined)
- 24 Fresh Basil Leaves
- 24 Thin Slices of Bacon

**Suggested Pit Boss Wood Pellet Flavour:** Cherry or Apple

**Preheat barbecue on PREHEAT then reduce to 275°F to 350°F**

Soak wooden skewers in water for 1 hour.

Rinse the shrimp under cold running water and then drain and blot dry with paper towel. Skewer the shrimp. Place a basil leaf on the back of each shrimp. Wrap each shrimp in a slice of bacon, starting at the top and turning the skewer to wind it on.

When ready to cook, arrange the shrimp on the hot grid, placing a folded sheet of aluminum foil under the exposed portion of the skewers to keep them from burning. Grill kabobs until the bacon is nicely browned and the shrimp are cooked through, 4 to 8 minutes in all, turning the kebobs to ensure even cooking. The shrimp will be firm and white when cooked through. DO NOT OVERCOOK!

**ALSO GOOD FOR:** Grill scallops, chicken tenders, or cubes of pork, veal, or beef on a stick.

## **CORNISH HENS WITH MANDARIN RICE**

Makes 4 servings

4	Whole	Cornish Game Hens
		Mandarin Rice (Below)
		Cooking Oil
		Paprika
		Orange Marmalade

**Suggested Pit Boss Wood Pellet Flavour:** Hickory, Mesquite or Competition Blend

**Preheat barbecue then reduce to MEDIUM ( 275—350°F)**

Rinse Cornish hens and pat dry with paper towels.

Prepare Mandarin Rice.

### **Mandarin Rice**

¼	Cup	Slivered Almonds
2	Tablespoons	Chopped Celery
1	Small	Green Onion And Top (thinly sliced)
2	Tablespoons	Butter
1	11 Ounce Can	Mandarin orange Segments (well-drained)
2	Tablespoons	Orange Juice (concentrate)
2	Cups	Cooked Rice

Sauté almonds, celery and onion in butter in small skillet until almonds are lightly toasted. Combine almond mixture, orange segments, orange juice concentrate and rice, tossing to a mix. Makes 3 Cups.

Stuff Cornish hens with mixture and tie legs with a string. Brush hens lightly with oil; sprinkle with paprika.

Place hens on cooking grid, If you want to catch the dripping to make gravy, place the hens in a foil pan and add enough water or juice to cover the bottom about ¼ inch thick. Grill until the stuffing reaches 165°F, the juices run clear and drumstick meat feels tender when pressed, about 45 to 60 minutes. Baste hens with orange marmalade during last 20 minutes of cooking time. Remove hens from cooking grate and arrange on serving platter.

## **WHOLE SMOKED TURKEY**

**Feeds a small army — Leftovers are even better tasting the next day.**

1	Whole	Turkey 20 – 25 pounds, thawed
		Original Texan Mesquite Seasoning
		Smoked Paprika
3	Tbsp	Soft Butter

**Suggested Pit Boss Wood Pellet Flavour:** Hickory, Cherry or Competition Blend

**Preheat barbecue on PREHEAT then reduce to MEDIUM (275°F—350°F)**

Remove the neck and giblets. Rinse turkey thoroughly and pat dry with paper towels.

Rub outer surface of turkey with Louisiana Grills Mesquite or Hickory Bacon Rub.

In a small container mix together the soft butter, mesquite and paprika together to form a paste. Gently insert your hand between the outer skin and the breast meat. Slowly rub paste inside the pocket.

Place turkey, breast side up, in center of cooking grid and grill until turkey is tender and golden brown; 11 to 13 minutes per pound or to an internal temperature of 180°F in the thickest part of the thigh and 170°F in the breast.

Remove turkey, cover with foil and let stand (rest) for 10 minutes before carving.

**Variation:** If you like to use the drippings to make a gravy with huge flavor, place a cookie cooling rack inside a large aluminum foil roast pan. Add approximately a ¼" of water or broth and some seasoning into the bottom of the pan. Place turkey on the cookie rack, close the lid and bake at 350°F till internal temperature is reached. You may need to add more water or broth during the roasting period.

## BEER-CAN CHICKEN

Makes 2—6 servings

1	4– 6 lb.	Whole Chicken
1	12 oz. can	Beer (chilled)
2-3	Tablespoons	"Louisiana Grills" - Key Lime Jerk or Chicken Rub

Suggested Pit Boss Wood Pellet Flavour: Hickory, Apple or Competition Blend



Preheat barbecue then reduce to MEDIUM (275°F—350°F)

Pull tab off the chilled beer. Pour 1/2 can into a frosty mug. Leave 1/2 in the can to be used for recipe. Using a church key-style can opener, make a few more holes in top of beer can.

Rinse chicken, inside and out, under cold running water. Drain and blot dry with paper towels. Sprinkle 1/4 of the rub inside the cavity of the chicken. Rub 1/2 of the rub on the entire outside of the bird.

Spoon remaining rub into the beer can. Carefully insert the upright can into the cavity of the chicken.

Place the upright can and chicken on the middle of the cooking grid. Cover grill and cook the chicken until it is golden brown and crispy. Using an instant read thermometer, insert it into the thickest part of the thigh, but not touching the bone. Internal temperature should be 165° F to 170° F. 1 1/4 to 1 1/2 hours.

Using tongs, carefully transfer upright chicken to serving platter. Let rest 5 minutes, then carefully remove the chicken from the can, be careful not to spill the HOT liquid. Carve, quarter or half the chicken and serve.

## NON-ALCOHOLIC BEER-CAN CHICKEN

*Using the same method as above, but substitute the can of beer with a can of your favourite non-diet cola, fruit flavour soda, root beer or water with extra seasoning.*

**TIP** Most prepared salad dressings make very quick, easy and tasty marinades for meats, poultry or fish.

## EASY RANCH CHICKEN SATAY

Makes 2—6 servings

1	Pound.	Boneless, Skinless Chicken Breast ( or Chicken Thighs)
1/4	Cup	Prepared Ranch or Italian Salad Dressing

Salt and Pepper to taste

Suggested Pit Boss Wood Pellet Flavour: Apple, Pecan or Cherry

Preheat barbecue then reduce to HIGH (425°F)

Cut breast, lengthwise, into 1/4 inch or slightly thicker pieces. Rinse the chicken under cold running water and blot dry with a paper towel.

Place chicken slices into a plastic zip-lock type bag. Pour the Ranch salad dressing into the bag with the chicken. Sprinkle with a little salt and pepper. Zip bag closed and carefully shake bag, coating chicken evenly with the liquid. Place in refrigerator for 1 to 2 hours, or over night. Turn and shake bag once or twice so the chicken marinades evenly.

Soak long wooden skewers in water for a minimum of 30 minutes.

When ready to cook, weave the chicken strips, in and out like a ribbon, onto the wooden skewers.

Brush the cooking grid with oil. Place the sates on the hot grid and grill until cooked, 2 to 3 minutes per side.

When done the chicken will turn white and be firm.

Good for a main entrée or as an appetizer.

# Section SIX: LIMITED WARRANTY

## LIMITED WARRANTY

The “Pit Boss” wood pellet barbecue line, manufactured by Dansons Inc., carries a one (1) year limited warranty for from the date of sale to the original owner only, against defects and workmanship on all steel parts, (excluding the burn pot), and one (1) year on electrical components. There is no specific warranty on the paint, burn pot, flame deflector, grill cover and all gaskets or against damage caused from corrosion.



### Conditions of Limited Warranty

During the term of the limited warranty, Dansons' obligation shall be limited to furnishing a replacement for covered, failed components, F.O.B. point of shipment. As long as it is within the warranty period, Dansons' will not charge for repair or replacement for parts returned, freight prepaid, if the part(s) are found by Dansons' to be defective upon examination. Dansons' shall not be liable for transportation charges, labour costs, or export duties. Except as provided in this CONDITIONS OF WARRANTY paragraph, repair or replacement of parts in the manner and for the period of time stipulated here under shall constitute the fulfillment of all direct and derivate liabilities and obligations from Dansons to you.

**The warranty coverage begins on the original date of purchase and proof of date of purchase, or copy of original bill of sale, is required to validate the warranty.**

Repair or replacement of the “Pit Boss” part does not extend the limited warranty beyond the one (1) year from date of purchase.

The pouring of liquids on your grill flame will void this warranty.

Dansons takes every precaution to utilize materials that retard rust by using high-temperature paint where advisable. Even with these safeguards, the protective coatings can be compromised by various substances and conditions beyond Dansons control. High temperatures, excessive humidity, chlorine, industrial fumes, fertilizers, lawn pesticides and salt are some of the substances that can affect paint and metal coatings. For these reasons, the limited warranties DO NOT COVER RUST OR OXIDIZATION, unless there is loss of structural integrity on the grill component. Should any of the above occur, kindly refer to you Instruction Manual's maintenance section for paint finish protection. Dansons' recommends that you purchase a Pit Boss full length protective cover, and cover your grill when not in use.

The warranties are based on normal domestic use and service of the grill and neither limited warranty coverage's apply for a grill which is used in commercial applications.



## Exceptions to the Limited Warranty

There is no written or implied performance warranty on **“Pit Boss” appliances**, as the manufacturer has no control over the installation, operations, cleaning, maintenance or the type of fuel burned.

This limited warranty will not apply nor will Dansons assume responsibility if your appliance has not been installed, operated, cleaned and maintained in strict accordance with the manufacturer's instructions. Burning other than quality wood pellets may void the warranty. The warranty does not cover damage or breakage due to misuse, improper handling or modifications.

**NEITHER THE MANUFACTURER, NOR THE SUPPLIERS TO THE PURCHASER, ACCEPTS RESPONSIBILITY, LEGAL OR OTHERWISE, FOR THE INCIDENTAL OR CONSEQUENTIAL DAMAGE TO THE PROPERTY OR PERSONS RESULTING FROM THE USE OF THIS PRODUCT. ANY WARRANTY IMPLIED BY LAW, INCLUDING BUT NOT LIMITED TO IMPLIED WARRANTIES OF MERCHANTABILITY OR FITNESS, SHALL BE LIMITED TO ONE (1) YEAR FROM THE DATE OF ORIGINAL PURCHASE. WHETHER A CLAIM IS MADE AGAINST THE MANUFACTURER BASED ON THE BREACH OF THIS WARRANTY OR ANY OTHER TYPE OF WARRANTY EXPRESSED OR IMPLIED BY LAW, MANUFACTURER SHALL IN NO EVENT BE LIABLE FOR ANY SPECIAL, INDIRECT, CONSEQUENTIAL OR OTHER DAMAGES OF ANY NATURE WHATSOEVER IN EXCESS OF THE ORIGINAL PURCHASE PRICE OF THIS PRODUCT. ALL WARRANTIES BY MANUFACTURER ARE SET FORTH HEREIN AND NO CLAIM SHALL BE MADE AGAINST MANUFACTURER ON ANY ORAL WARRANTY OR REPRESENTATION.**

Some states do not allow the exclusion or limitation of incidental or consequential damages, or limitations of implied warranties, so the limitations or exclusions set forth in this limited warranty may not apply to you. This limited warranty gives you specific legal rights and you may have other rights, which vary from state to state

The limited warranties for 1 (one) year are in lieu of all other warranties expressed or implied, at law or otherwise, and Dansons does not authorize any person or representative to assume for Dansons any obligation or liability in connection with the sale of the wood pellet grill. This means that no warranties, either expressed or implied, are extended to persons who purchase the product from any one other than Dansons or an authorized Dansons Dealer.

## Procedures for Warranty Service

Call your nearest “Pit Boss” dealer for repair or replacement of your “in-warranty” parts.

Be prepared to furnish the following information:

Copy of the bill of sale.

Purchaser's name, model and serial number of grill and date of purchase.

An accurate description of the problem.

**THIS LIMITED WARRANTY GIVES YOU SPECIFIC LEGAL RIGHTS AND YOU MAY HAVE OTHER RIGHTS, WHICH VARY FROM STATE TO STATE**

## SERIAL NUMBER AND MODEL NUMBER

YOUR SERIAL NUMBER AND THE MODEL NUMBER OF YOUR “PIT BOSS” CAN BE FOUND ON THE INSIDE OF YOUR HOPPER LID. BE SURE TO RECORD THESE IN THE SPACE PROVIDED BELOW TO AID YOU IF THEY GET DAMAGED OR LOST.

STAPLE YOUR ORIGINAL BILL OF SALE TO THIS PAGE AS WELL TO ENSURE YOU DO NOT LOSE IT!

MODEL

SERIAL NUMBER

DATE OF PURCHASE

AUTHORIZED DEALER



## Important Notice



**DO NOT RETURN PRODUCT TO STORE !**

**CONTACT "PIT BOSS" CUSTOMER SERVICE FIRST**

**1-877-303-3134 OR**

**service@pitboss-grills.com**



### **PARTS, SERVICE AND ACCESSORIES**

Dansons Inc. stands behind our Authorized Dealers. We Strongly suggest that if you do need to order any parts, options, or require service, that you first consult with your local dealer. Many dealers do stock current accessories, fuel and service parts.

If for any reason you do not have a local dealer, **Dansons Inc. is proud to offer the best technical and sales support in the industry. If you require accessories, rubs, spices, sauces, or parts, you can contact us directly.**



**PIT BOSS Customer Service**

**TOLL FREE: 1-877-303-3134**

**TOLL FREE FAX: 1-877-303-3135**

**Email: service@pitboss-grills.com**

**Website: www.pitboss-grills.com**

Proudly Made in China

PRINTED 0815

**CHECK OUR WEBSITE FOR UP-TO-DATE ACCESSORIES, OPTIONS, AND INFORMATION!**

