

Elite SCREENS

Portable Floor Pull-Up Screen

Elite ez Cinema Series

FOR MODELS: F60NWV / F72NWV / F84NWV / F100NWV /
F84NWH / F100NWH

USER'S GUIDE



MATTE WHITE

PARTS IDENTIFICATION:

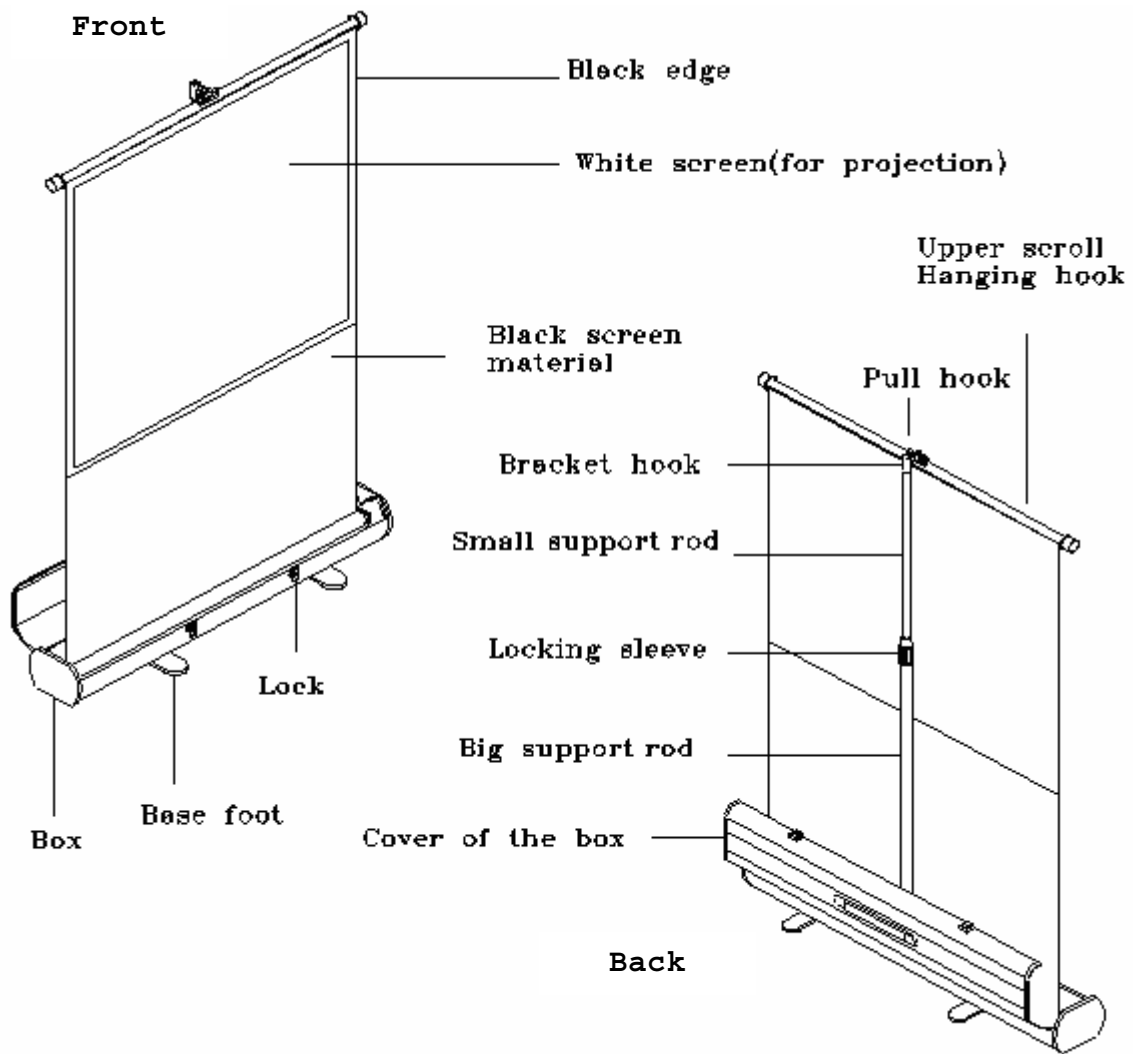

Precautions:



Warning! Screen damage can result from product mishandling if the enclosed precautions are not followed.



In accordance with practicing home fire safety and to avoid screen damage, do not place the screen near or beside a fireplace or high temperature appliances such as a gas stove, BBQ or heater. (Fig. 1)

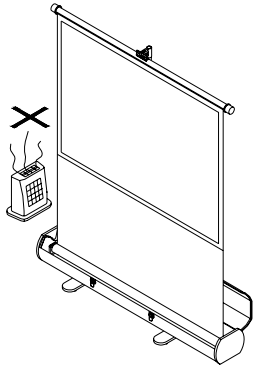

Fig.1

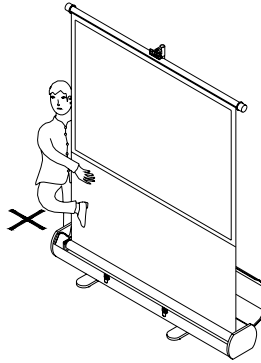

Fig.2



Place the screen beyond the reach of children. (Fig.2)

Operational Instructions:

Installation:

The EZ-Cinema screen is designed to be used as an easy to operate portable screen for a variety of presentation environments. Its design enables it to be versatile for use in either classroom, conference room, home or patio presentations. When packed, the unit carries with ease and opens up for projection presentations within seconds. As a general rule, portable projector screens should be installed in an area free from wind and heat or open flame sources such as a heater, BBQ grill or fireworks display.

Extend the base feet:

Locate the base feet on the bottom of the box cover at each end and rotate the base foot until it forms a right angle between the footboard and the cover box.

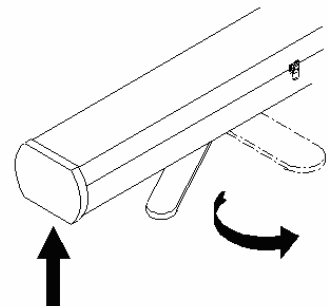

Open the box cover:

Unlatch the buckles on both ends of the box and open the box cover. Next, secure the box with one hand while removing the support rod with your other hand.

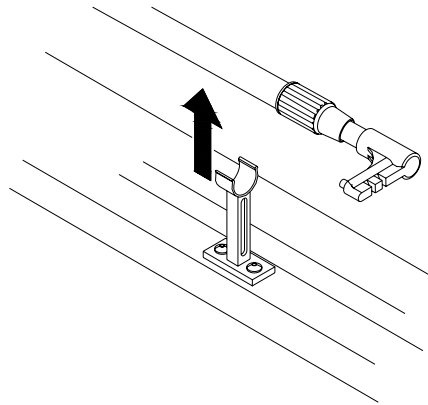

Installing the support rod:

First, make sure that the hanging hook is pointing toward the front facing the same direction as the screen, then insert the square end of the support rod into the support plate as shown below.

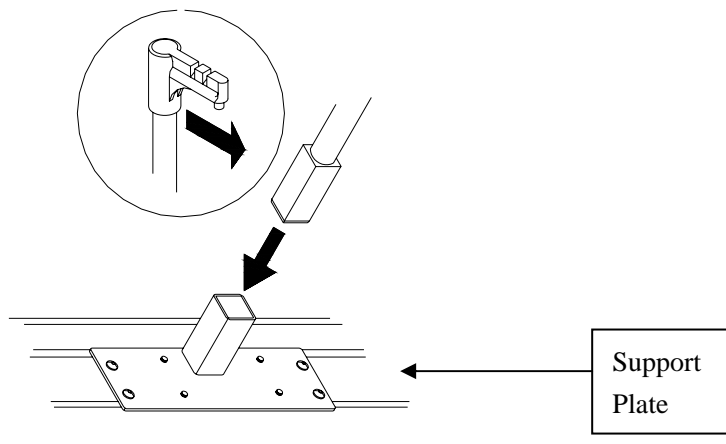

Pull up the screen:

Hold the pull hook with one hand, pull the screen up gently and hang it on the bracket hook.

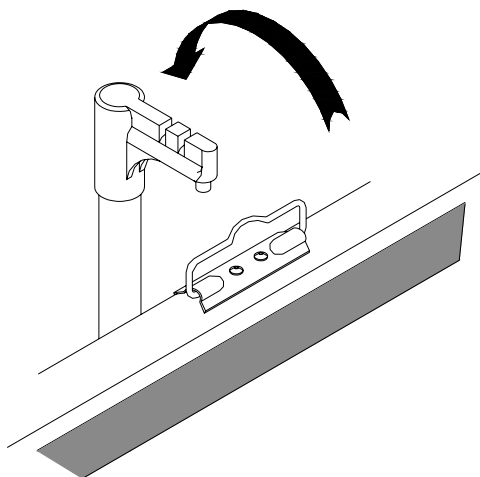

Vertical Adjustment:

First loosen the locking sleeve, and then hold the small support rod with the left hand so as to slowly raise it upwards until the screen is fully stretched to the desired position.

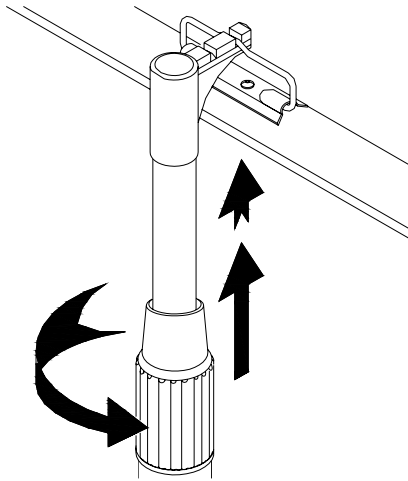

Adjusting the screen:

Hold the screen with the left hand when the screen has been stretched to the desired position, and then rotate the locking sleeve clockwise with the right hand until the rod is properly locked into position.

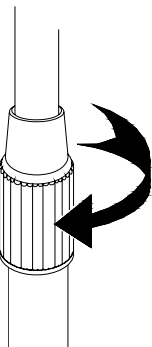

Screen completely assembled

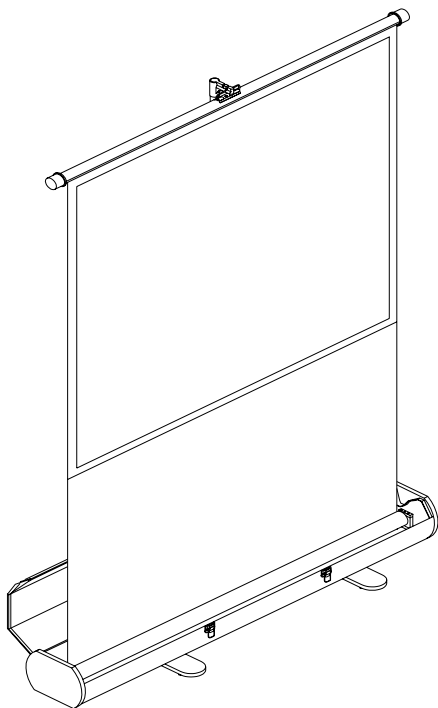

Preparing screen for storage

1. Pulling down the screen:

First, hold the telescoping support rod with the left hand and loosen the locking sleeve counter-clockwise with the right hand. Then shorten the telescoping support rod slowly into the full retracted position and tighten the locking sleeve to secure it in place.

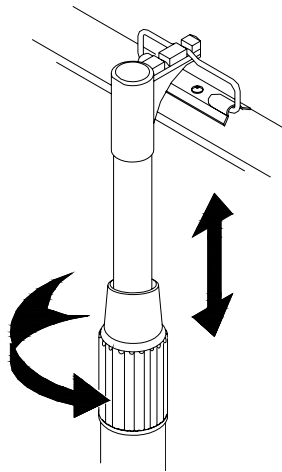

2. Retract the screen:

Remove the pull hook from the support bracket by lifting it about 2 cm up and then hold on to the pull hook and lower the screen gently into the box.

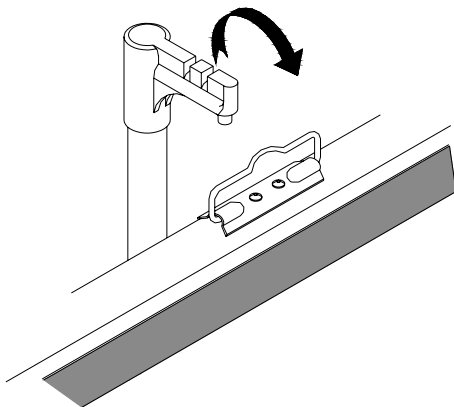

3. Pulling out the support rod:

After telescoping the small supporting rod to its shortest position and tightening the locking sleeve, take out the supporting rod from the support plate.

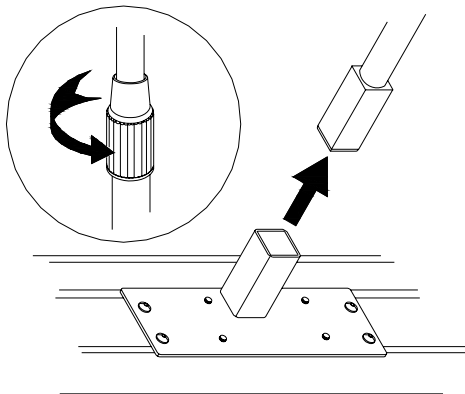

4. Storing the support rod:

Properly center the supporting rod in the middle to maintain the weight balance in the box when carrying.

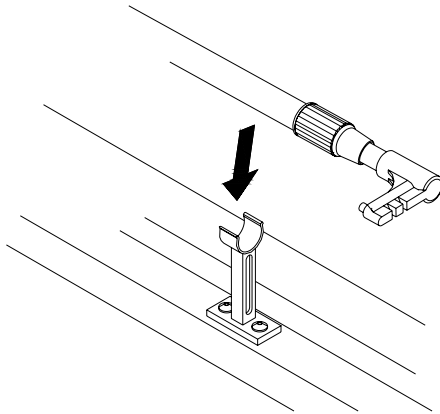

5. Draw the base feet back:

Slightly lift each end of the box in turn rotating the two base feet underneath until they are back into alignment with the box.

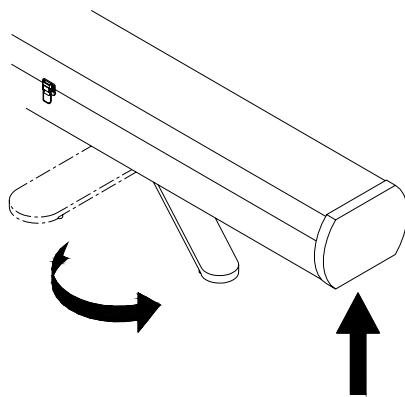

6. Storing the screen:

The recommended place for storage would be a corner of the room or in a closet, but the ultimate choice is up to you.

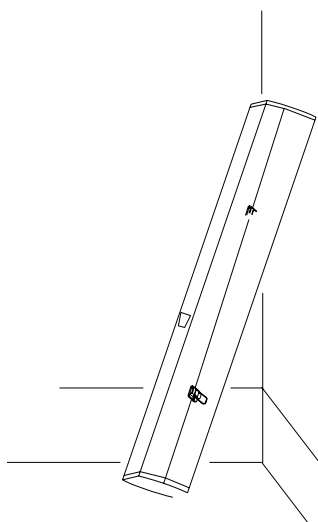

The following points should be noted to assure the sound performance of the screen

1. Never use your hand to touch the screen surface.
2. Never scrub on the screen with anything.
3. Don't touch the screen with hard or sharp objects.
4. Please use a clean cotton cloth or soft dust brush to remove any dust particles on the screen.
5. The screen material may be cleaned

Warranty Policy - Manual, Tripod, Pull-up Floor, and Fixed Frame Screens

**Warranty policy applies to claims made in the United States of America. Warranty issues outside of the US must go through their international distributor.*

- **Two (2) year warranty parts and labor from purchase date as follows (except for refurbished units as specified below):**
- **Refurbished units carry a 90-day parts and labor warranty.**
- **Demo units or open box items are AS IS items and do not carry a warranty.**
- **Elite Screens will cover ground shipping charges on warranty claims made within 7 days of receiving per our DOA (Defective On Arrival) policy**
- **Each party will be responsible for one way shipping during the regular warranty period if the claim is made after the 7 day DOA period.**
- **An RMA (Return Merchandise Authorization) number must be issued in order to process a replacement. Elite Screens will either replace or repair the defective unit with a brand new replacement *(see exceptions below) after the defective unit is received and/or confirmed defective. Once the product is received, Elite Screens will send out a new *unit to the customer by ground service (subject to inventory availability).**
- **Missing Parts must be reported within the 7-days of receipt. If reported after 7 days, customer will only be responsible for shipping and handling fees. If reported after 30 days of receipt, the customer is responsible for cost of the parts and shipping & handling fees.**

Please visit the link below for full warranty information

<http://www.elitescreens.com/services.html>

**A new or refurbished replacement will be sent out to the customer depending on the type of purchase (new or refurbished) and is based on stock availability.*

TWO WAY TO REGISTER YOUR WARRANTY WITH ELITE SCREENS INC.

A. On Line (Faster and Easier) www.elitescreens.com/register.html

B. Fill out & Fax to (562) 483-8498, Attn: Customer Service Dept.

*Your Name: _____

Address: _____

City/State/Zip _____

*Email Address: _____

*Phone: _____

*Screen Model: _____

*Serial Number: _____

*Date of Purchase: _____

*Dealer / Reseller Purchased from (name of the reseller): _____

What is your Projector Model : _____

Application: Home Education Corporation Government
 Others

How would you rate this screen? Excellent Good Ok Improvement needed

Comments:

Contact info:

If you have pictures of your screen you'd like to share with us, please email your pictures to eliteinfo@elitescreens.com or call us at 877-511-1211

*Elite*SCREENS

www.elitescreens.com

For any technical inquiries,

techsupport@elitescreens.com