



Home Theater Fixed Frame Curved Projection Screen

# Lunette Series



# Important Safety & Warning Precautions

Please follow these instructions carefully to ensure proper maintenance and safety with your screen.

1. Please make sure that no other objects such as power switches, outlets, furniture, ladders, windows, etc. occupy the space designated to hang the screen.
2. Regardless if the screen is installed inside or on the wall, make sure that the proper mounting anchors are used and that the weight is supported appropriately by a strong and structurally sound surface just as any large and heavy picture frame should. (Please consult a home improvement specialist for the best advice on installation.)
3. Frame parts are made of high quality velour-surfaced aluminum and should be handled with care.
4. When not in use, cover the screen with a furniture sheet to protect from dirt, grime, paint or any other impurities.
5. When cleaning, use a damp soft cloth with warm water to remove any marks on the frame or screen surface.
6. Never attempt to use any solutions, chemicals or abrasive cleaners on the screen surface.
7. To avoid damaging the screen, do not touch the material directly with your fingers, tools or any other abrasive or sharp objects.
8. Spare parts should be placed out of reach for small children in accordance with household safety guidelines .

## Caution:

- **The projection screen frame is made of high-quality aluminum alloy and should be handled with care.**
- **Use a soft cloth with warm water to remove any spots on the screen surface.**
- **To avoid damaging the screen material, never attempt to use any solutions, chemicals or abrasive cleaners on the screen, and avoid touching the material with your fingers or sharp/abrasive objects.**

# Parts List for the Lunette Series

Please make sure all parts listed below are included before proceeding with the installation.



A. Dry-wall anchor

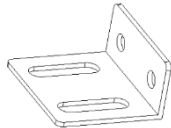

B. 1.77" L-Bracket

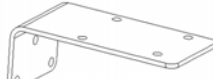

C. 3.54" L-Bracket

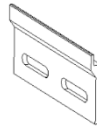

D. Y-Bracket



E. M5 Screw



F. Wood Screw



G. Fix Plate



H. Center Support Bar



I. Support Joiner

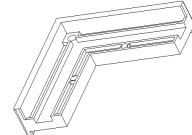

J. Elbow Joint



K. Butterfly Screw

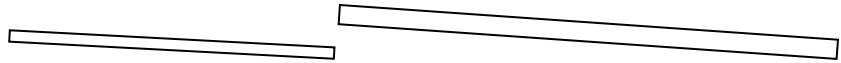

L. Tension Rods



M. Vertical Upright Frame

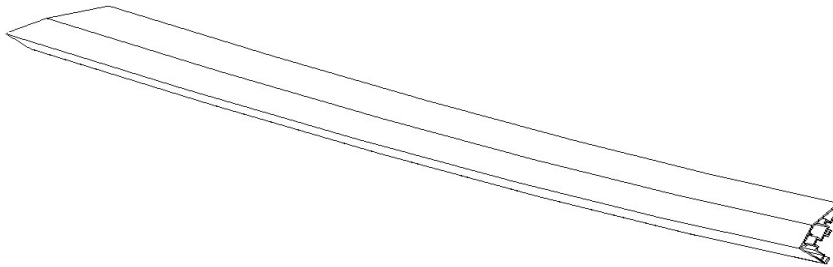

N. Horizontal Curved Frame

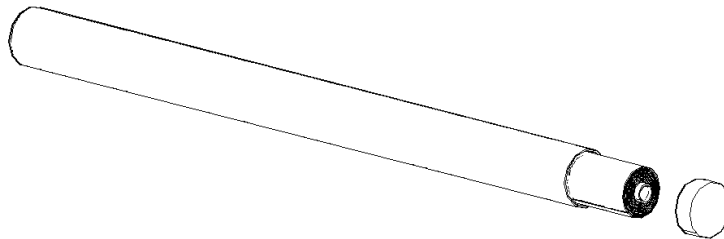

O. Screen Material

# Installation Instructions

## Assembly

1. Insert both **Elbow Joints (J)** into each **Horizontal Curved Frame (N)** and join all four frame parts together as shown below.



2. After making sure that all four corners join at right angles to form a perfect rectangle and fasten together with the **M5 screws (E)**.

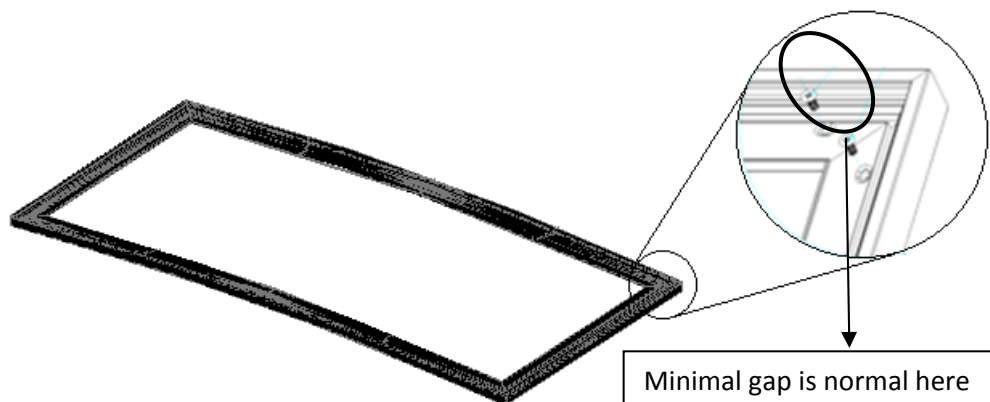

3. Lay out the **Screen Material (O)** and **Tension Rods (L)** on a clean and dry surface and gently roll out the screen material on the back of the frame.

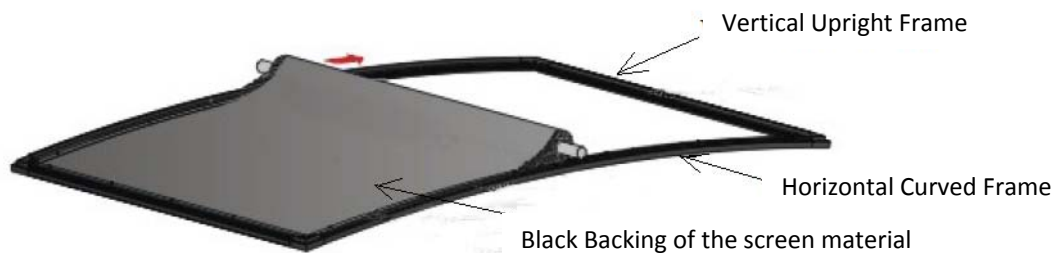

4. Insert the screen **Tension Rods (L)** through the sleeves according to their corresponding length on each edge of the screen.

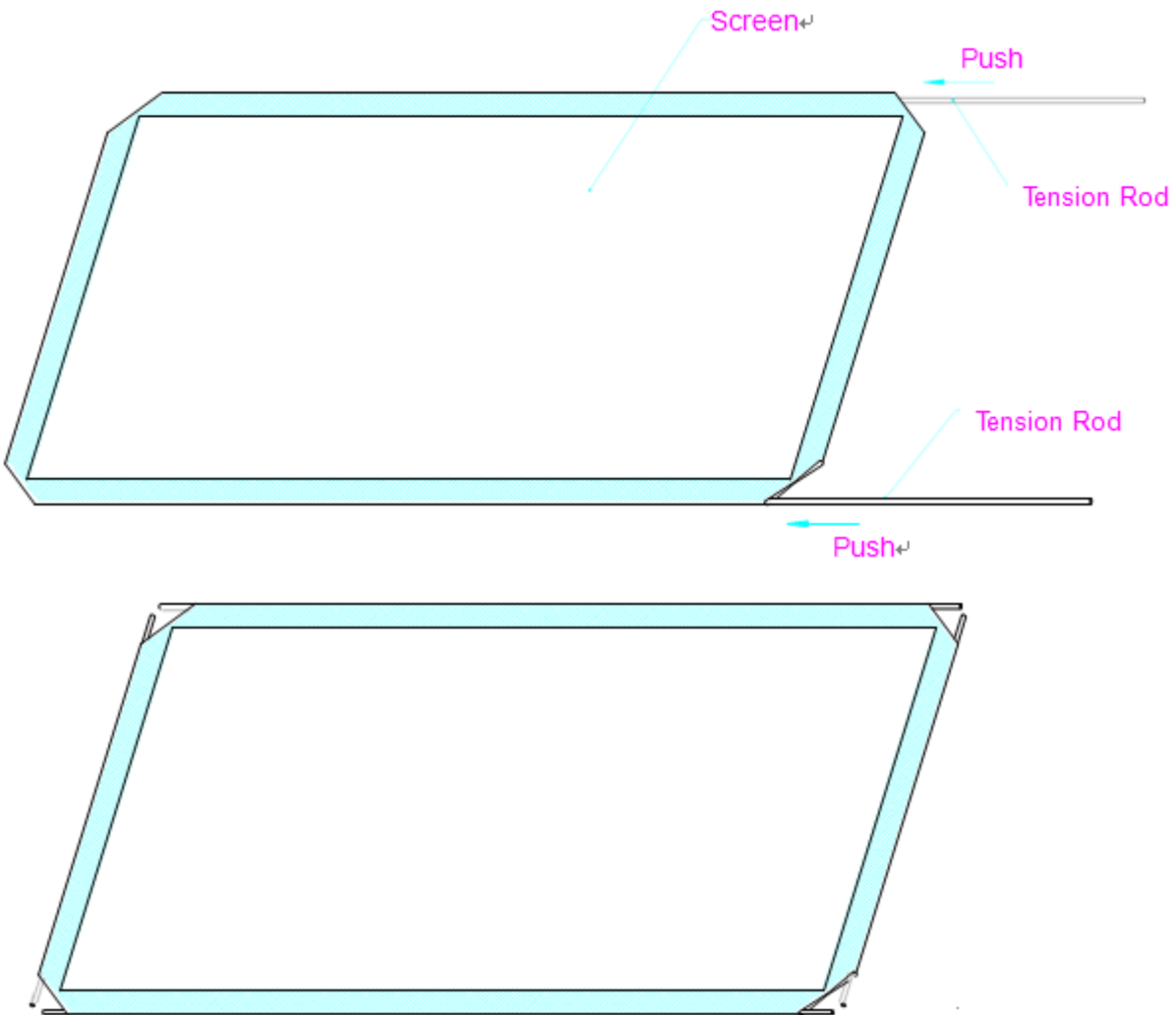

5. Slip the tension rods into the grooves running along each side on the back of the frame. Clip on the Fix Plates (F) to the back of the frame to secure the rods into place forming a tight and flat surface.

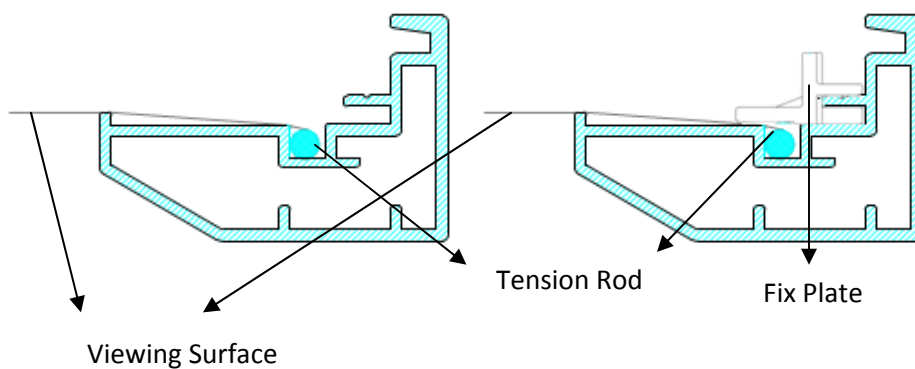

## Black Backing for AcousticPro1080 Models

This procedure only applies to AcousticPro 1080 models, disregard if your curved frame is now an AcousticPro 1080 variant. The black backing counters the effects of light penetration that would otherwise light up all items behind the screen and spoil the picture.

The black backing goes behind the projection surface and is held into position by Velcro-faced fix plates.

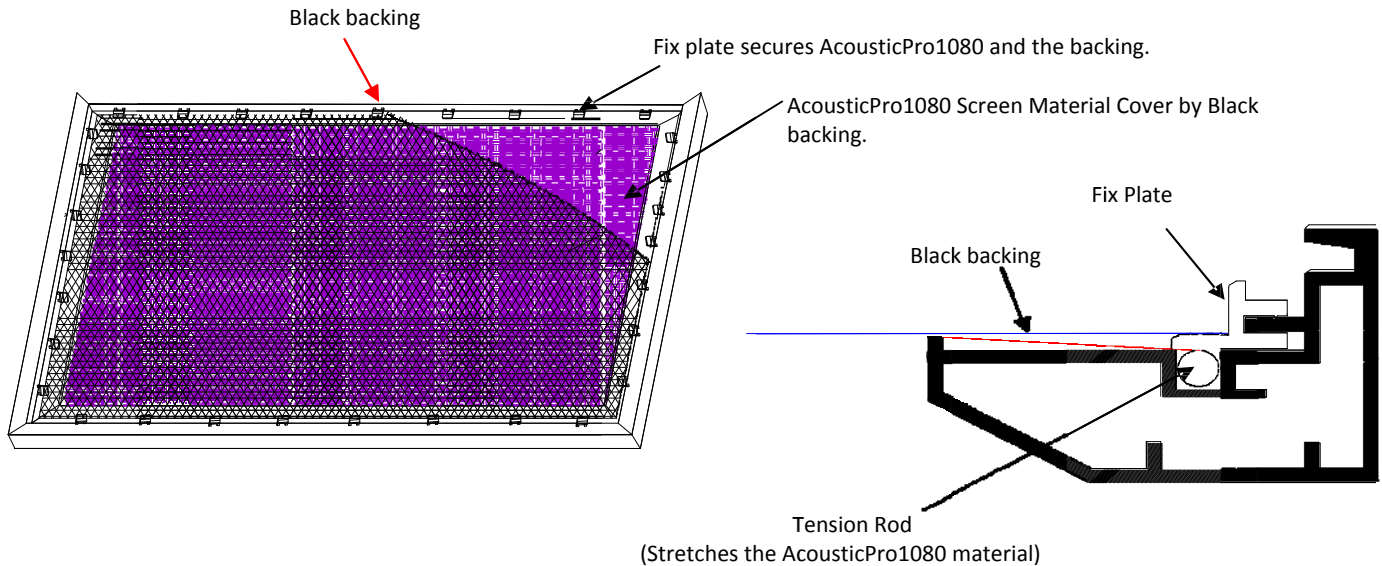

After the material has been installed, the backing will lie over the back of the white (AcousticPro1080) material and then be held into place by the fix plates as they're added (Fig.1-3). Interval markings reveal the suggested points of attachment (Fig.1). The prongs on the fix plates (Fig.2) straddle a lip on the back of the frame creating friction to hold the material in place (Fig.3-4).



Fig.1



Fig.2

\*An alternate way to attach the black backing to the back of the AcousticPro1080 material is to utilize the Velcro tabs located on the outer surface of the fix plates (Fig. 3-4).

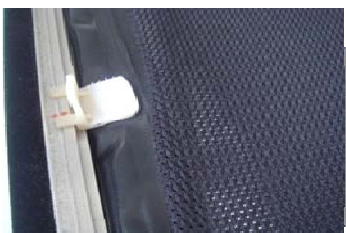
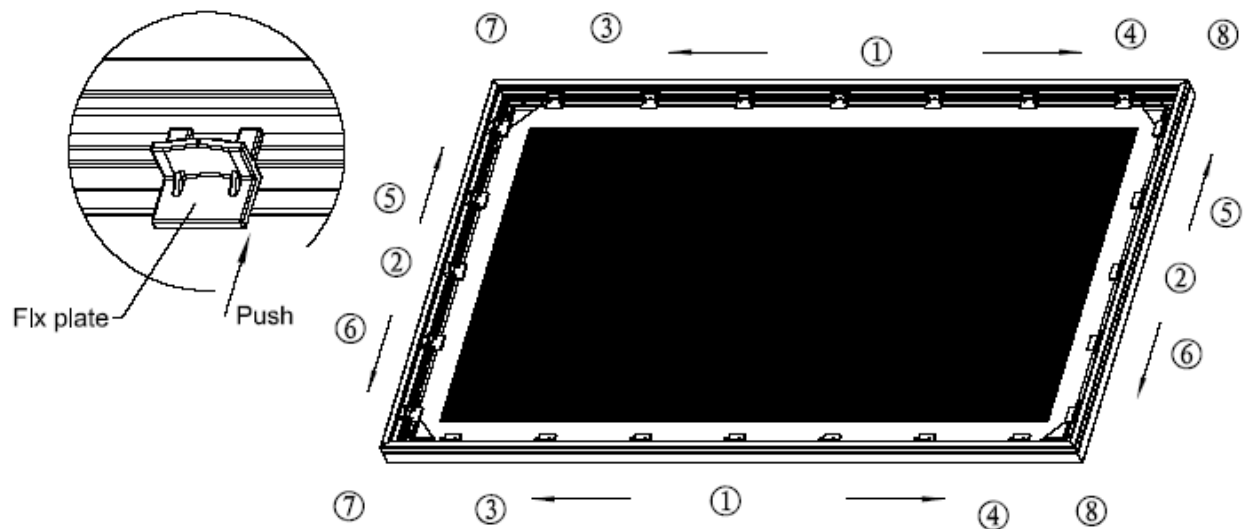

Fig.3



Fig.4

## ATTACH THE FIX PLATES



1. Make sure that the material and frame are lying face down on a clean, dry and non-abrasive surface.
2. Center the material inside the frame.

**Note: The material will be noticeably smaller because stretching the material is required to create a sufficient amount of tension for perfect material flatness.**

3. Start attaching the Fix Plates in the center of the Horizontal Curved Frame's edge and (1) then alternate with the center short sides (2).

Note: Follow these instructions to make sure the material is properly fixed in the center position of the frame. After attaching the **Fix Plates** in sequence #2 (the center of the short sides), please remove the fix plates in sequence #1 (the center of the long horizontal edge) and reattach them again, and also remove the fix plates on sequence# (2) and reattach them again.

4. Then continue to follow our recommended order numbers 3-8 to properly distribute tension to the screen material.

# CENTER SUPPORT BAR

1. Insert the **Support Joiner (I)** into each side of the **Center Support Bar (H)** to complete assembly.

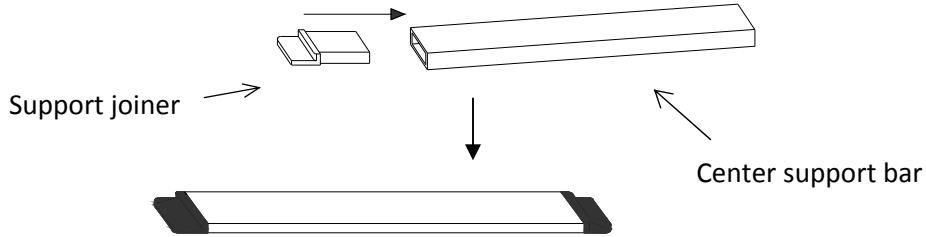

2. Insert the **Center Support Bar (H)** into the upper top groove on the back of the frame (not the one where the fix plate inserts) with the bottom end near the approximate center point of the frame and place it in at an angle so that both ends of the bar are in alignment with the groove.
3. Slide the top end of the end bar into the top center point location as shown below to complete the center support bar installation. This will provide added stability to your frame and add tension to the material.

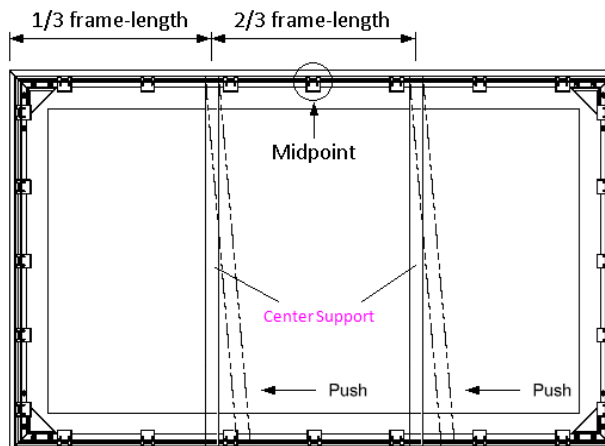
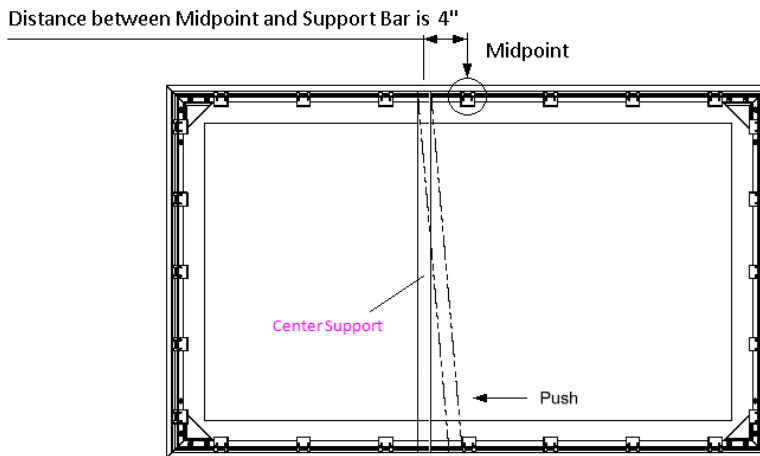



# INSTALLATION

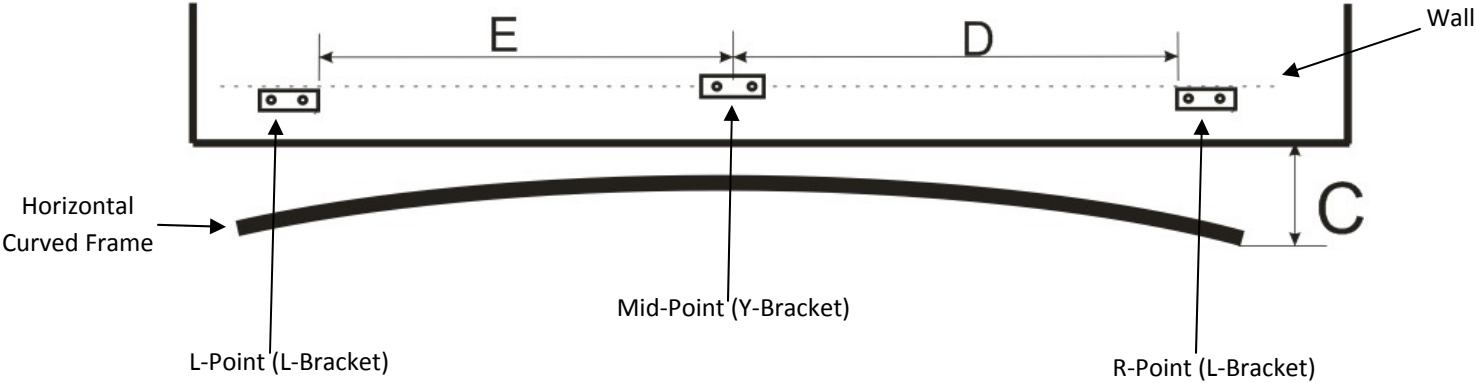
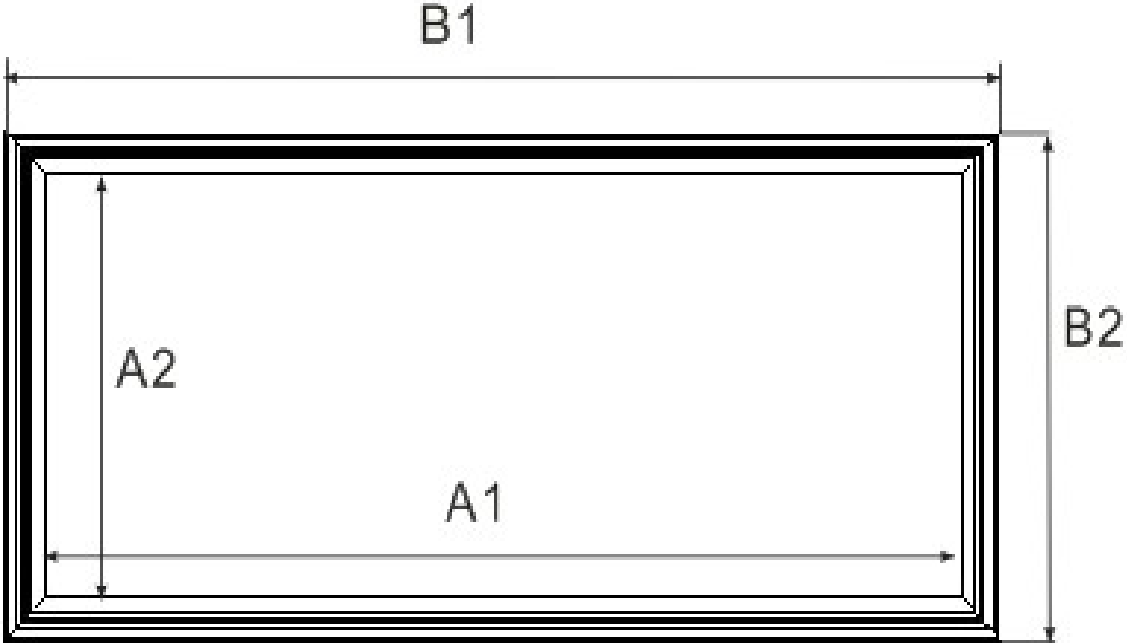

1. Locate your desired installation height, draw the **Datum Line** and mark the drill-hole area of the **Mid-Point**. Note: The center of the hole must align with the **Datum Line**.
  2. Mark the drill-hole area of the **L-Point** and the **R-Point**. The top of the bracket must align with the **Datum Line**.
  3. Drill a hole with the proper bit size according to the included **Wood Screws (F)**.
  4. Line up the brackets with the drilled holes on the installation location and screw them in using a Phillips screwdriver.
  5. Position the fixed frame screen onto the **Y-Bracket (D)** and push down at the center of the bottom frame to secure the insertion of the frame into the Y-Bracket.
  6. Combine the **1.77" L-Bracket (B)** with the installed mounted **3.54" L-Bracket (C)** using the **Butterfly Screws (K)** and then position frame onto the bracket.
- Note: Step 6 only refers to models 125w and above. Models 85w-115w use four 1.77" L-Brackets (B).**
7. The brackets provide flexibility by allowing the fixed frame screen to slide to the slides. This is an important feature as it allows your screen to be properly centered.

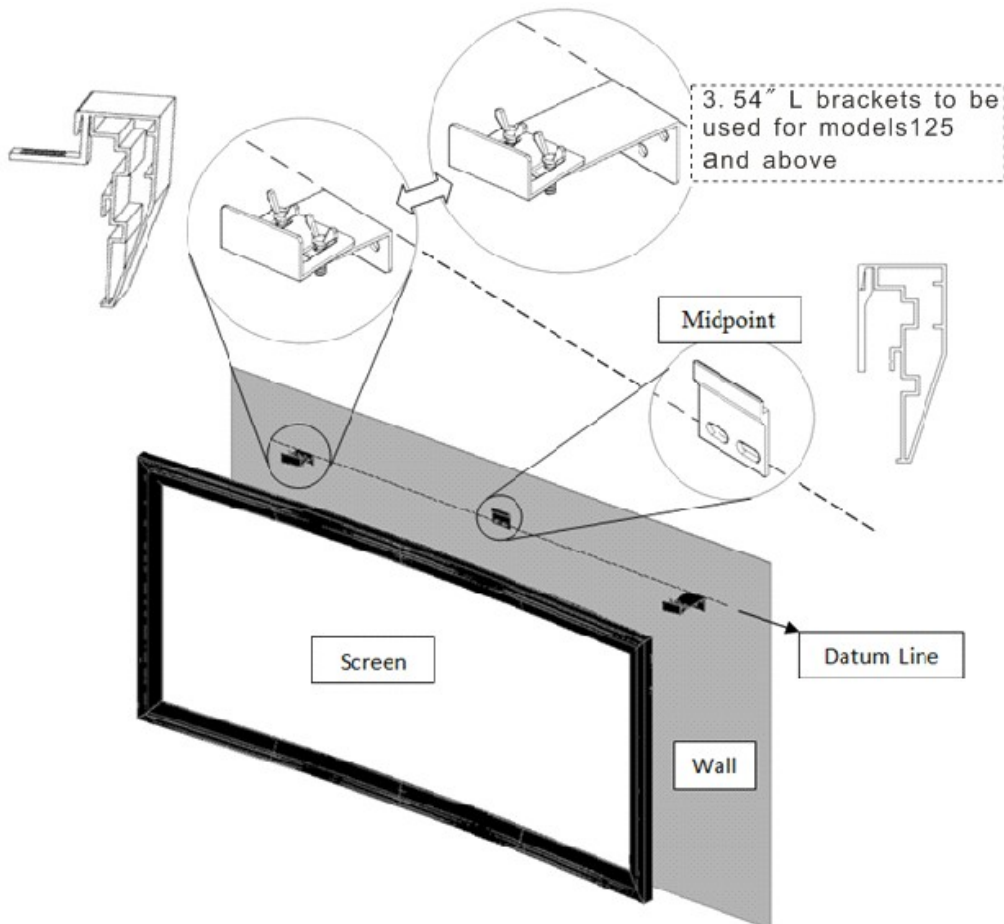

## Model Numbers Parts List Curve235-

Part Name	Model Number							
	85w	96w	103w	115w	125w	138w	147w	158w
Horizontal Curved Frame	2	2	2	2	2	2	2	2
Upright Vertical Frame	2	2	2	2	2	2	2	2
Elbow Joint	4	4	4	4	4	4	4	4
M5*15 Assembly Screw	9	9	9	9	9	9	9	9
Screen Material	1	1	1	1	1	1	1	1
Top/Bottom Tension Rod	2	2	2	2	2	2	2	2
Side Tension Rod	2	2	2	2	2	2	2	2
Center Support Bar	1	1	1	1	2	2	2	2
Support Joiner	2	2	2	2	4	4	4	4
Fix Plate	44	52	52	56	62	66	68	72
Dry-wall anchor	7	7	7	7	9	9	9	9
M5*45 Wood Screw	7	7	7	7	9	9	9	9
1.77" L-Bracket	4	4	4	4	2	2	2	2
3.54" L-Bracket	0	0	0	0	2	2	2	2
Y-Bracket	1	1	1	1	1	1	1	1
Butterfly Screw	5	5	5	5	5	5	5	5

## Dimensions of Diagram on page 9

Model Number	View Width (A1)	View Height (A2)	Overall Width (B1)	Overall Height (B2)	Frame Height (C)	Distance (D)	Distance (E)
85w	78.19" (1986)	33.28" (845)	85.28" (2166)	40.35" (1025)	3.39" (86)	39.96" (1050)	39.96" (1050)
96w	88.35" (2244)	37.56" (954)	95.43" (2424)	44.65" (1134)	3.86" (98)	45.28" (1150)	45.28" (1150)
103w	94.77" (2407)	40.31" (1024)	101.85" (2587)	47.40" (1204)	4.17" (106)	47.24" (1200)	47.24" (1200)
115w	105.83" (2688)	45.00" (1143)	112.90" (2868)	52.09" (1323)	4.80" (122)	51.18" (1300)	51.18" (1300)
125w	115.00" (2921)	48.90" (1242)	122.09" (3101)	55.98" (1422)	5.35" (136)	59.06" (1500)	59.06" (1500)
138w	126.97" (3225)	53.98" (1371)	134.06" (3405)	61.06" (1511)	6.22" (158)	62.99" (1600)	62.99" (1600)
147w	135.24" (3435)	57.52" (1461)	142.32" (3615)	64.6" (1641)	6.81" (173)	66.93" (1700)	66.93" (1700)
158w	145.40" (3693)	61.81" (1570)	152.48" (3873)	68.90" (1750)	7.56" (192)	68.90" (1750)	68.90" (1750)

Measurement dimensions are intended as a reference only and subject to change without notice. Note: Data Error may be ±1"  
Unit: (mm)

# Lunette Series Dimension Table

Unit: mm										
Model	Diagonal Size/Aspect Ratio	Overall Width (A)	Viewing Width (A1)	Frame Width (A2)	Overall Height (B)	Viewing Height (B1)	B2	C	Frame Depth (D)	E
Curve235-85W	85"(2.35:1)	2166	1986	90	1025	845	90	86	40	1050
Curve235-96W	96"(2.35:1)	2423	2243	90	1134	954	90	98	40	1150
Curve235-103W	103"(2.35:1)	2587	2407	90	1204	1024	90	106	40	1200
Curve235-115W	115"(2.35:1)	2867	2687	90	1323	1143	90	122	40	1300
Curve235-125W	125"(2.35:1)	3101	2921	90	1423	1243	90	136	40	1500
Curve235-138W	138"(2.35:1)	3405	3225	90	1552	1372	90	158	40	1600
Curve235-158W	158"(2.35:1)	3872	3692	90	1751	1571	90	192	40	1750
Unit: Inches										
Model	Diagonal Size/Aspect Ratio	Overall Width (A)	Viewing Width (A1)	Frame Width (A2)	Overall Height (B)	Viewing Height (B1)	B2	C	Frame Depth (D)	E
Curve235-85W	85"(2.35:1)	85.3	78.2	3.5	40.4	33.3	3.5	3.4	1.6	41.3
Curve235-96W	96"(2.35:1)	95.4	88.3	3.5	44.6	37.6	3.5	3.9	1.6	45.3
Curve235-103W	103"(2.35:1)	101.9	94.8	3.5	47.4	40.3	3.5	4.2	1.6	47.2
Curve235-115W	115"(2.35:1)	112.9	105.8	3.5	52.1	45.0	3.5	4.8	1.6	51.2
Curve235-125W	125"(2.35:1)	122.1	115.0	3.5	56.0	48.9	3.5	5.4	1.6	59.1
Curve235-138W	138"(2.35:1)	134.1	127.0	3.5	61.1	54.0	3.5	6.2	1.6	63.0
Curve235-158W	158"(2.35:1)	152.4	145.4	3.5	68.9	61.9	3.5	7.6	1.6	68.9

Measurements are intended as a reference only and are subject to change without notice. Note: Data Error may be ±1"

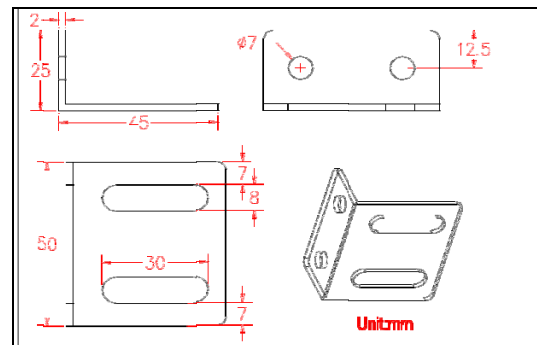
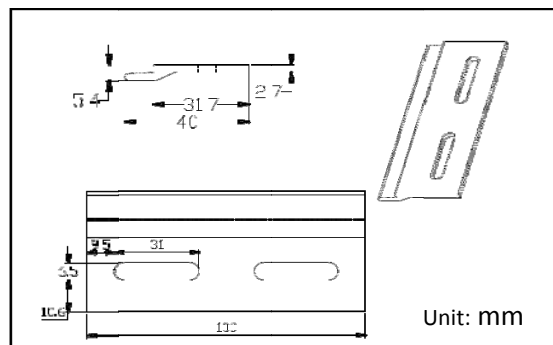
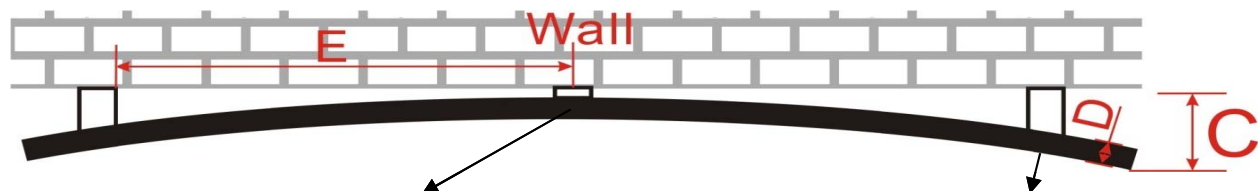
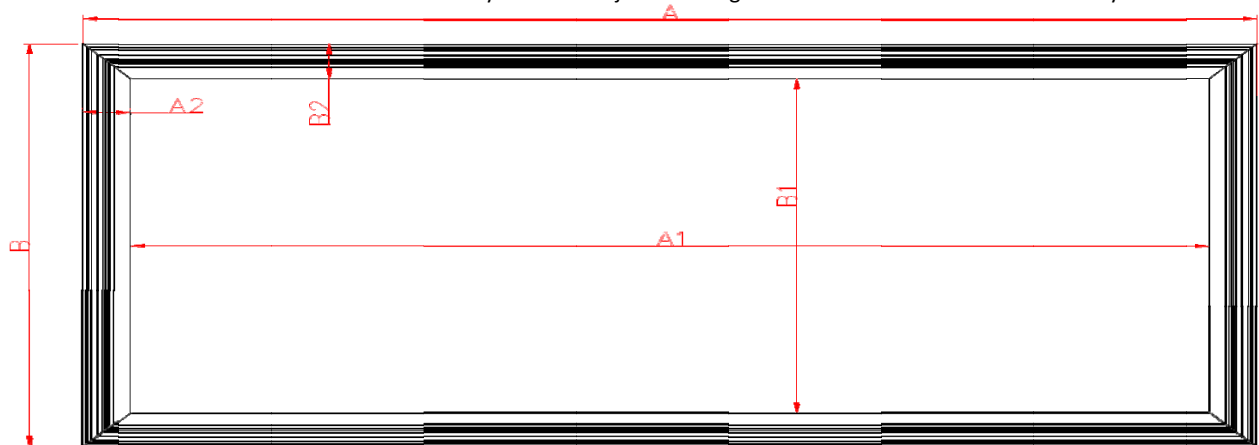

# Warranty Policy

- **Two (2) Year** parts and labor warranty from defects in workmanship from purchase date as follows (except for refurbished units as specified below).
- **Three (3) Year** parts and labor warranty from defects in workmanship for **GEMR** (Government, Educational, Military, & Religious) purchases of new product only.
- **Refurbished Units** carry a **90-DAY** parts and labor warranty.
- Each party will be responsible for one way shipping during the warranty period.
- A **RMA (Return Merchandise Authorization) number** must be issued in order to process a replacement or to authorize a return for warranty repair. Elite Screens will, at its sole option replace or repair the defective unit with a replacement \*(see exceptions below) after the defective unit or parts have been received. Once the product is received, Elite Screens will send out a replacement \*unit to the customer by ground service (subject to inventory availability).
- **Do Not Return Any Unauthorized Items to Elite Screens, as they will be refused and returned at your expense. The RMA Number must be included on the outside label of your shipping box. Our warehouse is not authorized to accept returns without an RMA number on the shipping label.**
- **RMA Numbers are valid for 45 days from the date issued.**
- **Missing Parts** must be reported within 7 days of receipt. If reported after 7 days, the customer will be responsible for shipping and handling fees. If reported after 30 days of receipt, the customer will be responsible for cost of parts and shipping & handling fees.

\*A New or refurbished replacement will be send out to the customer depending on the type of purchase (new or refurbished) and based on stock availability.

## **North America only U.S. and Canada**

For Warranty and Service requests, please submit an RMA/Service Form at:  
[www.elitescreens.com/warrantysupportform](http://www.elitescreens.com/warrantysupportform)

Please visit this link for full Warranty information:  
[www.elitescreens.com/warranty](http://www.elitescreens.com/warranty)

For Customer Service and Technical questions, please contact Elite Screens at:  
Telephone: (877) 511-1211 [service@elitescreens.com](mailto:service@elitescreens.com)  
Fax: (562) 926-8433 [techsupport@elitescreens.com](mailto:techsupport@elitescreens.com)

**REMEMBER TO REGISTER YOUR PRODUCT AT:**

**[www.elitescreens.com](http://www.elitescreens.com)**

# Contact Info

US & Canada Tech Support & Warranty Claim

Please contact us at [service@elitescreens.com](mailto:service@elitescreens.com) or call +1 877-511-1211 #3 or fax +1-562-926-8433

Europe Tech Support & Warranty Claim

Please contact us at [service@elitescreens.eu](mailto:service@elitescreens.eu) or call +49-(0) 40-30392958

Asia Tech Support & Warranty Claim

Please contact us at [service@elitescreens.com.cn](mailto:service@elitescreens.com.cn) or call +86-(0) 755-8461-7989

Taiwan Tech Support & Warranty Claim

Please contact us at [service@elitescreens.com.tw](mailto:service@elitescreens.com.tw) or call +866+2+8990-1999

## America:

### Elite Screens Inc

16410 Manning Way  
Cerritos, CA 90703 USA  
Tel: +1-877-511-1211  
Fax: +1-562-926-8433  
[info@elitescreens.com](mailto:info@elitescreens.com)  
[www.elitescreens.com](http://www.elitescreens.com)

## Europe:

### Elite Screens Europe

Lübecker Straße 1  
22087 Hamburg, Germany  
Tel: +49-4030392494  
Fax: +49-40-49219200  
[info@elitescreens.eu](mailto:info@elitescreens.eu)  
[www.elitescreens.eu](http://www.elitescreens.eu)

## Asia:

### Elite Screens China Corp.

Longxi Duimianling Industry Zone  
Longcheng Longgang District,  
ShenZhen Guangdong, China  
Tel: +86-(0)755-8461-7989  
Fax: +86-(0)755-8461-7669  
[info@elitescreens.com.cn](mailto:info@elitescreens.com.cn)  
[www.elitescreens.com.cn](http://www.elitescreens.com.cn)

## Elite Screens France S.A.S

11, Allée William Penn  
92150 Suresnes, France  
Tel: +33-1-45064735  
Fax: +33-1-45064735  
[info.fr@elitescreens.com](mailto:info.fr@elitescreens.com)  
[www.elitescreens.com/fr](http://www.elitescreens.com/fr)

## Taiwan:

### Elite Screens Taiwan Corp.

4F., No. 42-1 Wuguan Rd. Wugu Township Taipei  
County 248, Taiwan (Wugu Industrial Park)  
Taiwan (R.O.C)  
Tel: +886+2+8990-1999  
Fax: +886+2+8990+1366  
[info@elitescreens.com.tw](mailto:info@elitescreens.com.tw)  
[www.elitescreens.com.tw](http://www.elitescreens.com.tw)

## Japan:

### Elite Screens Japan Corp.

467-2-606 Tsuruma, Machida-shi,  
Tokyo, 194-0004 Japan  
Tel: 0120-07-0008  
Fax: +81(0)42-706-9130  
[info@elitescreens.jp](mailto:info@elitescreens.jp)  
[www.elitescreens.jp](http://www.elitescreens.jp)

## Latin America Contact:

[Info.la@elitescreens.com](mailto:Info.la@elitescreens.com)

## East Asia Contact:

[Info.ea@elitescreens.com](mailto:Info.ea@elitescreens.com)

## India Contact:

[Info.ea@elitescreens.com](mailto:Info.ea@elitescreens.com)