

DESCRIPTION

ITEM NAME: ...TALL UNIT.....

PRODUCT CODE: ...KL-COR-004.....

TOP TIPS BEFORE YOU START !

- 1) Please check that all parts are present before you start the assembly of your furniture.
- 2) For ease and speed of assembly, we recommend that before you commence each step of the assembly, that you identify all the parts required for that step.
- 3) For large items, please ensure that you have sufficient space and people to assemble your product safely.
- 4) We recommend that, where possible, all items are assembled near to the area in which they will be placed in use, to avoid moving the product unnecessarily once assembled.
- 5) For the protection of your furniture, particularly items to high gloss finish, we recommend that the product is placed on a protected surface during assembly to prevent any damage.
- 6) During assembly, please take care not to over-tighten any fittings, as this may damage the product.

CARE AND MAINTENANCE OF YOUR FURNITURE

GENERAL FOR CABINETS

- Please periodically check all fittings and re-tighten as necessary.
- To clean your item, please use a damp cloth and wipe clean.
- Never allow any kind of liquid to remain on your furniture. Absorption can cause wood to warp or finishes to de-laminate.
- Please do not place hot items (e.g. hot drinks) directly on to the wood surface.
- Please do not drag and pull your furniture.

DESCRIPTION

ITEM NAME: ...TALL UNIT.....

PRODUCT CODE: ...KL-COR-004.....

PARTS LIST

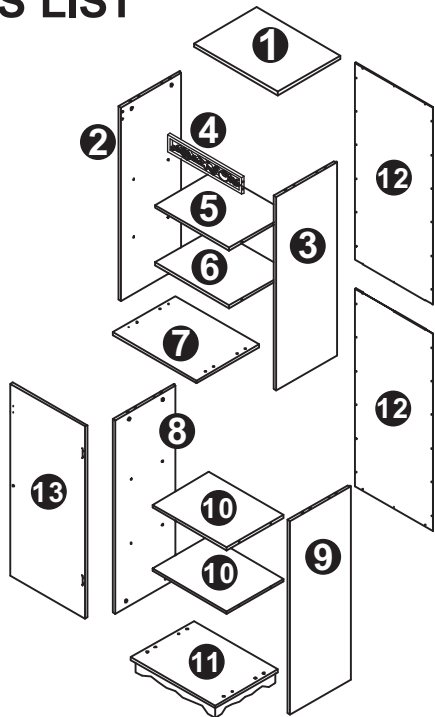

NO.	PART LIST	QTY
(1)	TOP PANEL	1
(2)	UPPER LEFT SIDE PANEL	1
(3)	UPPER RIGHT SIDE PANEL	1
(4)	SCROLL FRETWORK PANEL	1
(5)	UPPER SHELF PANEL	1
(6)	UPPER SHELF PANEL	1
(7)	MIDDLE FIXED SHELF	1
(8)	LOWER LEFT SIDE PANEL	1
(9)	LOWER RIGHT SIDE PANEL	1
(10)	LOWER SHELF PANEL	2
(11)	BOTTOM PANEL	1
(12)	BACK PANEL	2
(13)	DOOR	1

HARDWARE LIST

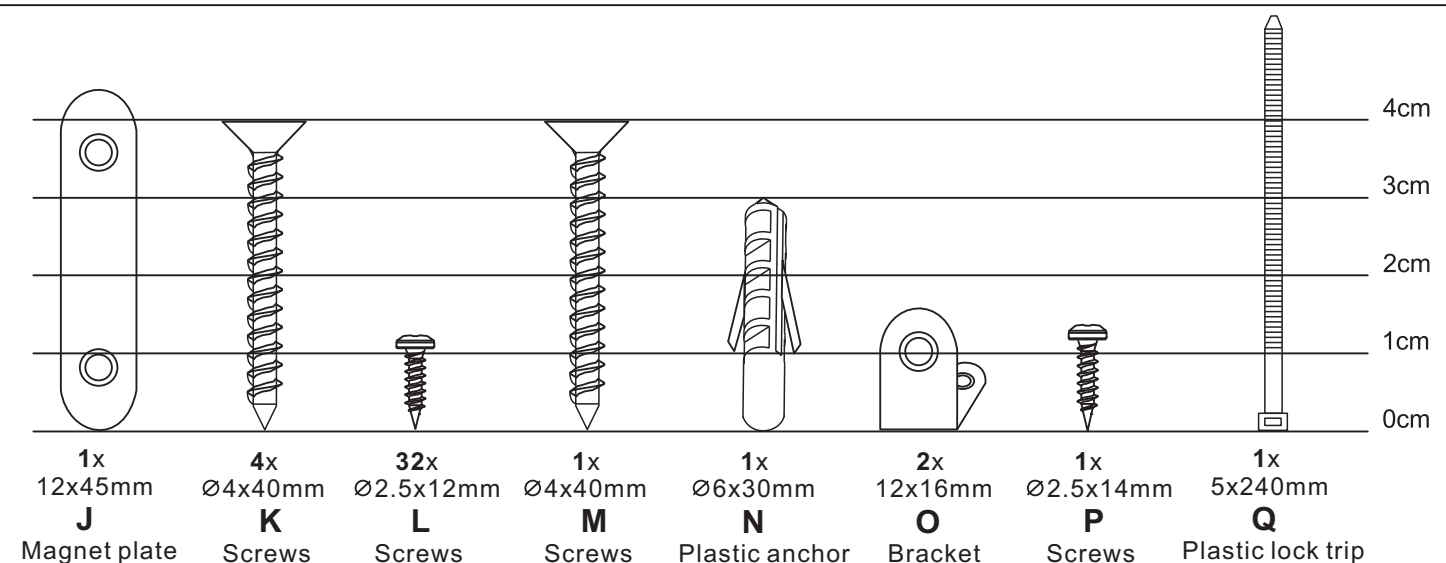
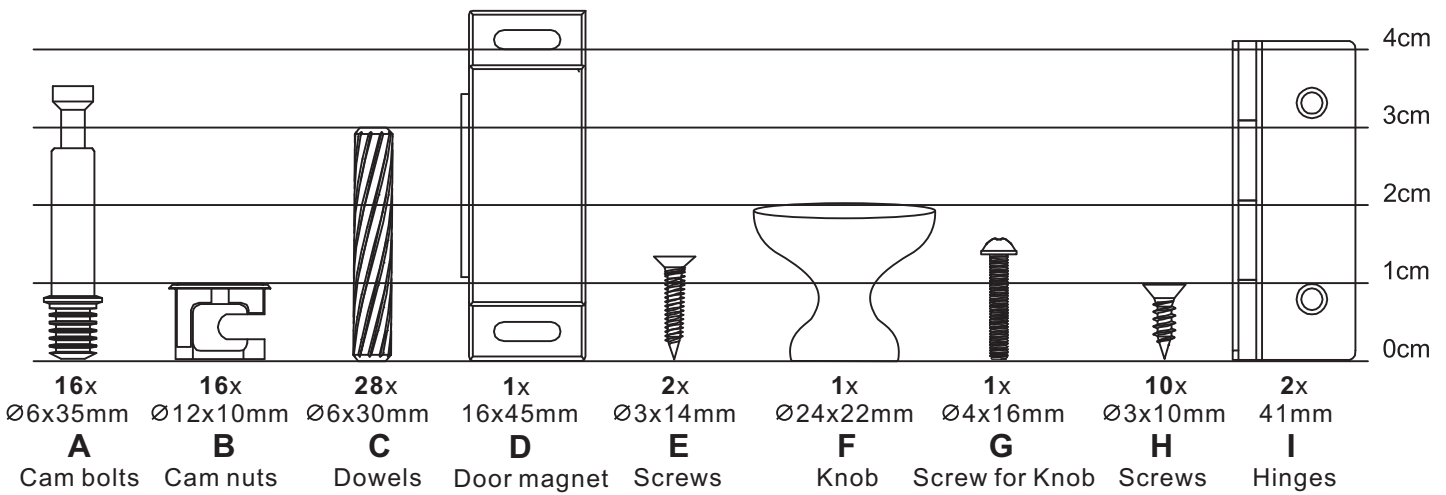

DESCRIPTION

ITEM NAME: ...TALL UNIT.....

PRODUCT CODE: ...KL-COR-004.....

STEP1

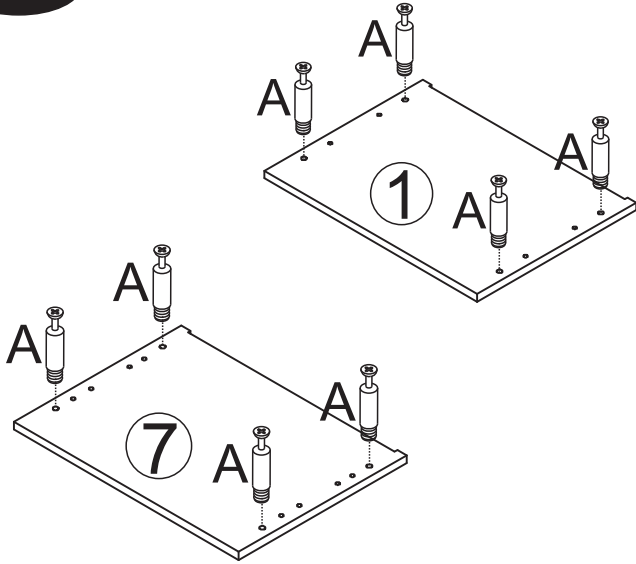

STEP2

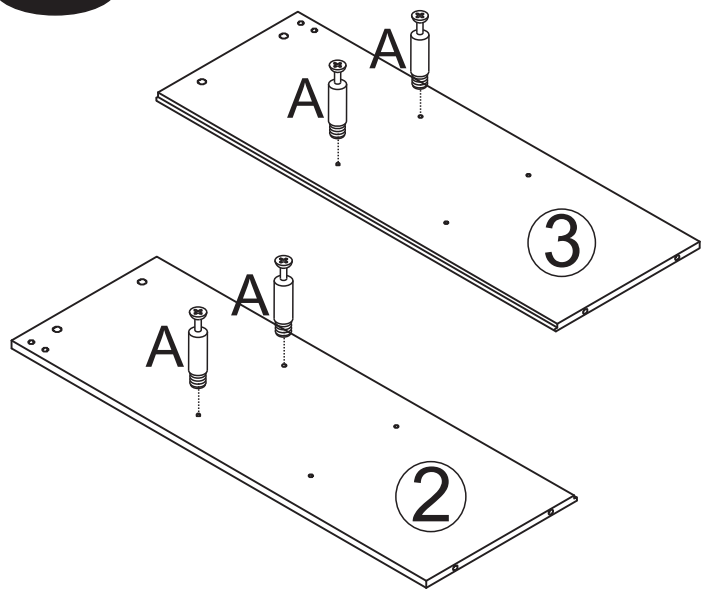

STEP3

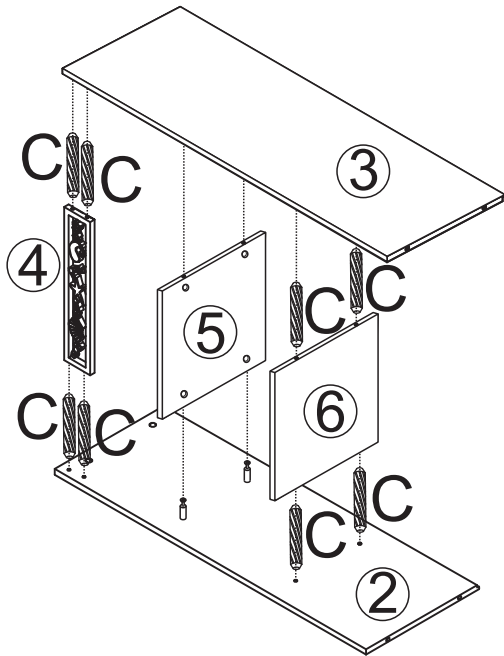

STEP4

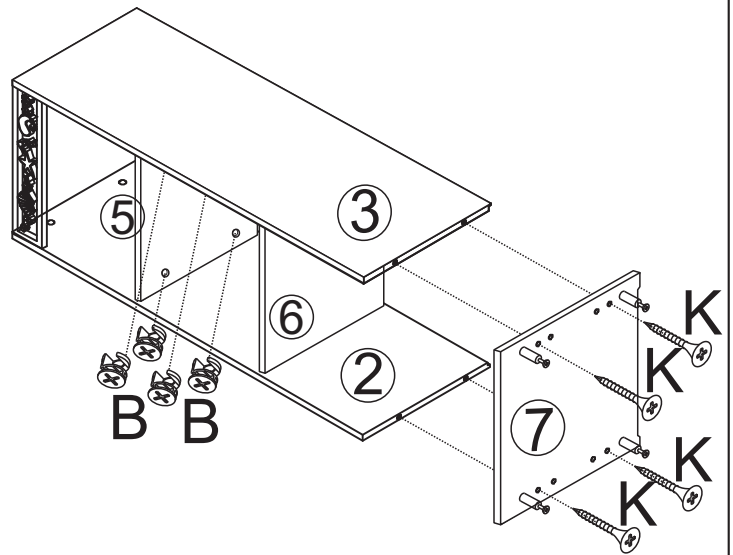

STEP5

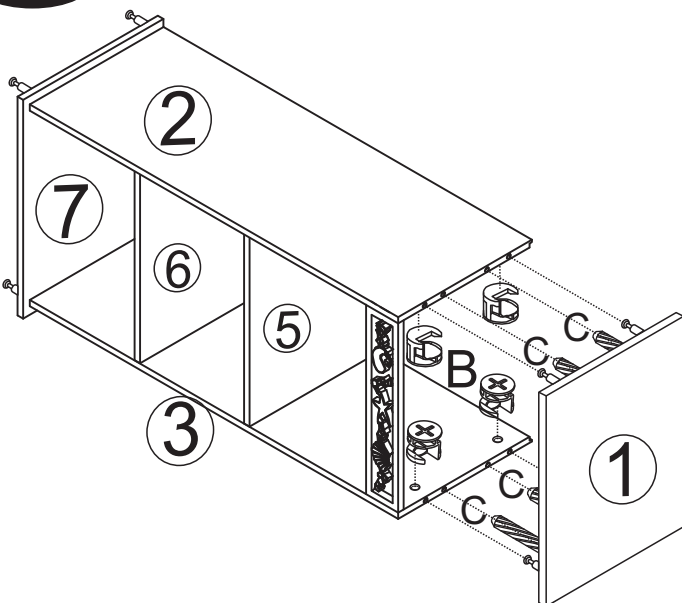

STEP6

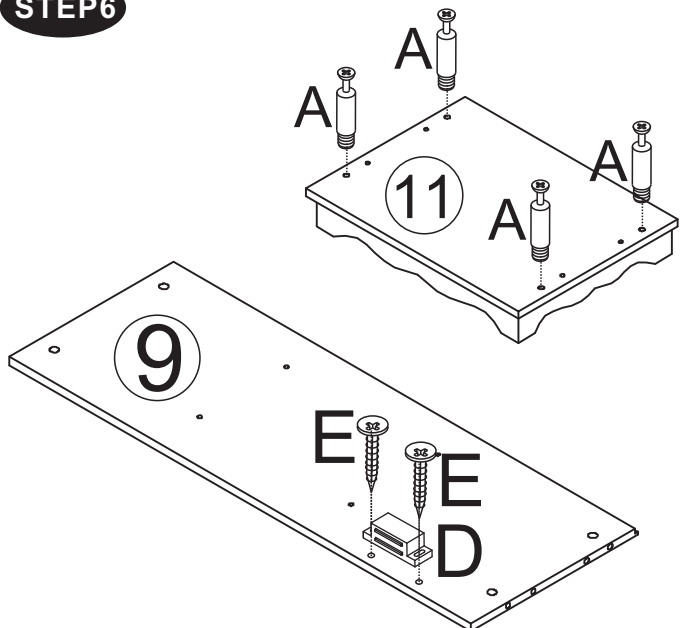

DESCRIPTION

ITEM NAME: ...TALL UNIT.....

PRODUCT CODE: ...KL-COR-004.....

STEP 7

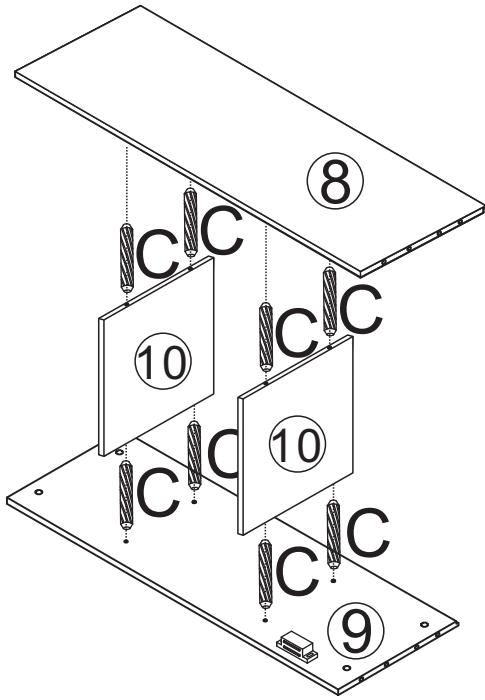

STEP 8

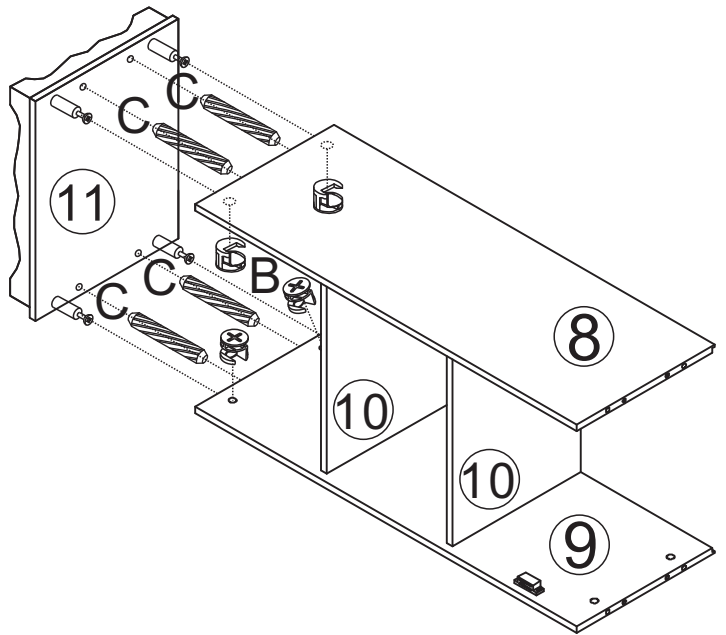

STEP 9

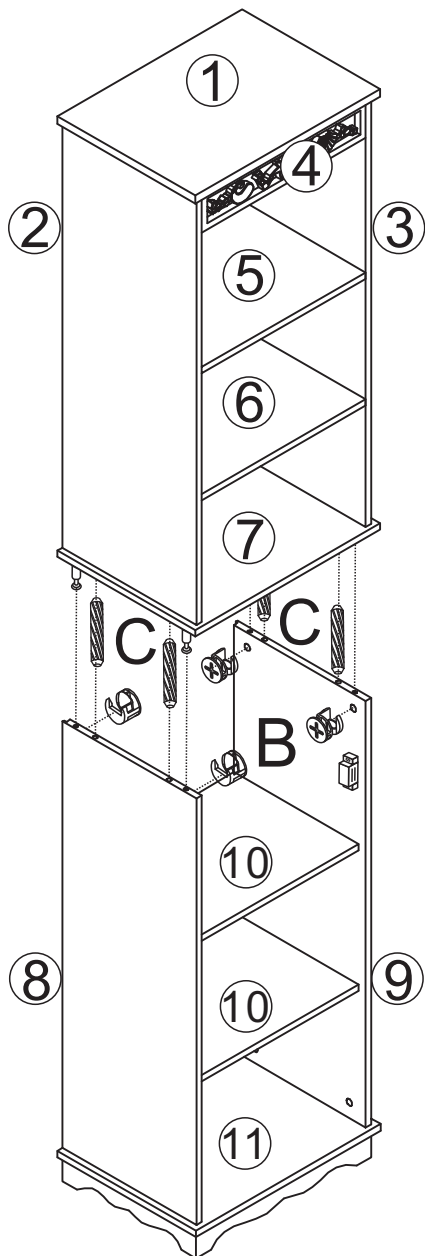

STEP 10

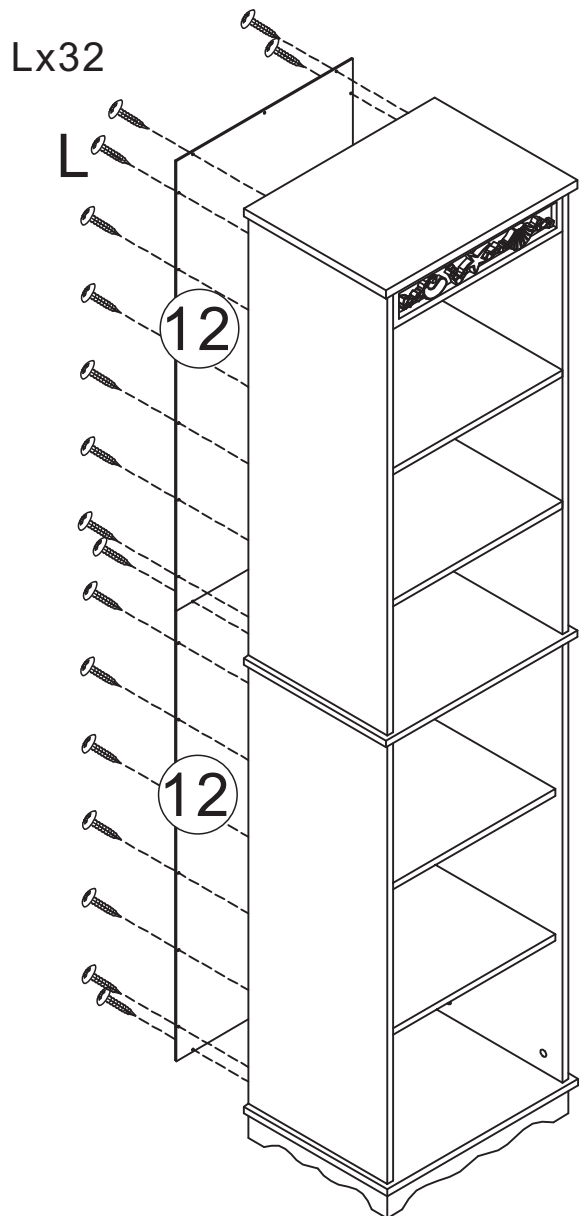

DESCRIPTION

ITEM NAME: ...TALL UNIT.....

PRODUCT CODE: ...KL-COR-004.....

STEP11

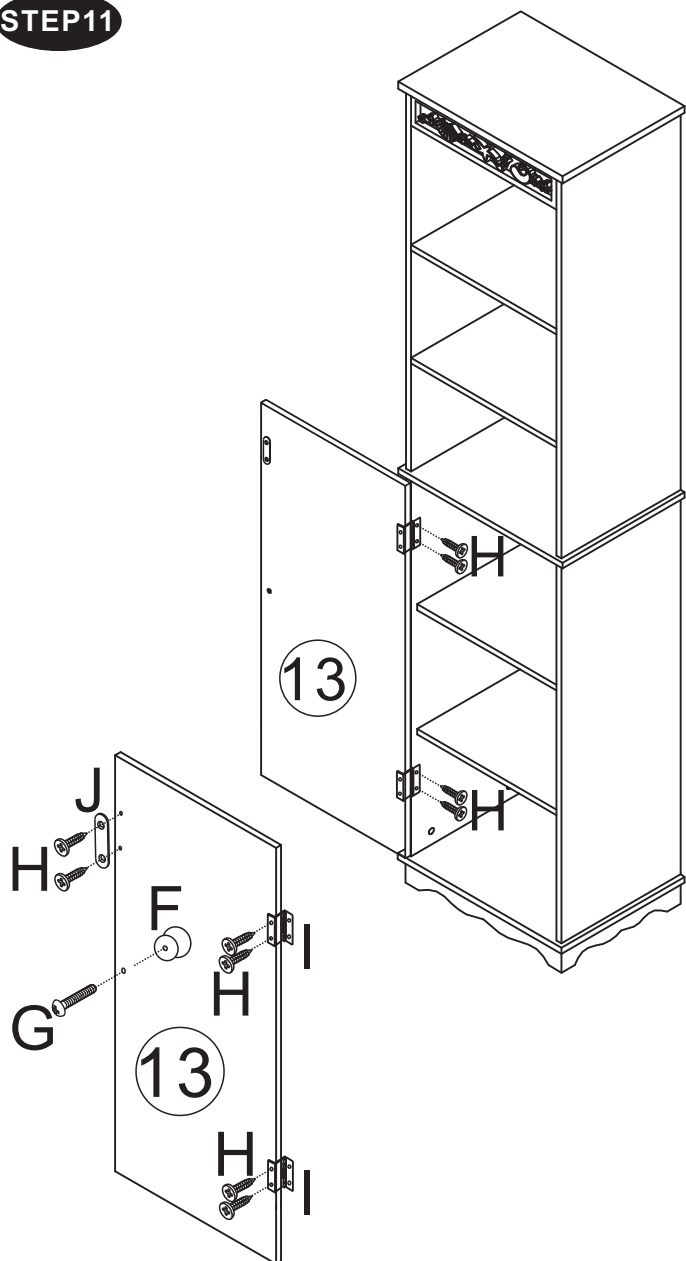

STEP12

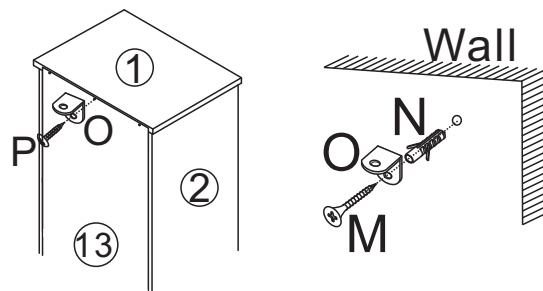

STEP13

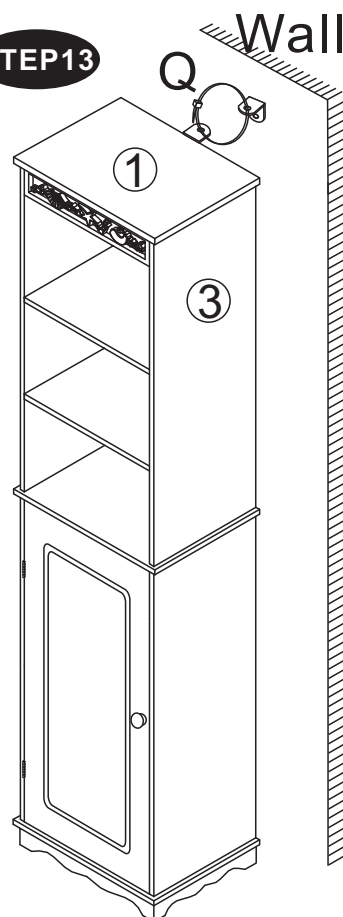

WALL FIXING INSTRUCTIONS

Serious or fatal crushing injuries can occur from furniture tip-over. To prevent this furniture from tipping over it must be permanently fixed to the wall.

Different wall materials require different types of fixing devices. Use fixing devices suitable for the walls in your home if the one provided in the package is not suitable.

Please assess the wall where you wish to fix the unit and purchase the necessary fixings, if in doubt seek expert advice from your local specialized dealer or DIY shop. Then you should proceed as follows :

- 1) Ensure the wall is clean & sound.
- 2) Mark the desired position of the accessory with a pencil, use a spirit level if required, to ensure it is level.
- 3) Use the correct drill bit for the type of wall (ensure you do not drill into electrical cables/water pipes), NB a special drill is required for ceramic tiles.
- 4) Once the hole has been drilled, insert the correct fixing. If the fixing to ceramic tiles ensure the wall plugs, are pushed in beyond the depth of the tiles.