











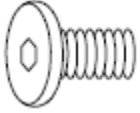

T BAR STOOL

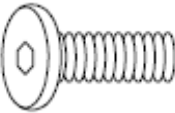
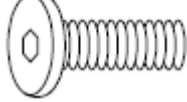
Parts List

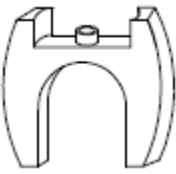
Please review all parts and hardware before disposing of any packaging. Call Customer Service if missing hardware. Do not return to store/retailer.

Using a screw that is too long will cause damage. Before beginning assembly, separate each type of screw. Carefully study the screw diagrams below.

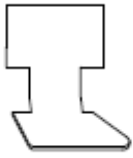
You may receive extra hardware with your unit.

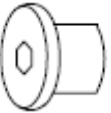
A  Quantity Of 1 Chair Leg A	B  Quantity Of 1 Chair Leg B	C  Quantity Of 1 Bolt C
D  Quantity Of 2 Bolt D	E  Quantity Of 2 Bolt E	F  Quantity Of 4 Bolt F
G  Quantity Of 5 Lock Washer	H  Quantity Of 4 Plastic Clip	I  Quantity Of 4 Foot Pad
J  Quantity Of 1 Bottom Shelf	K  Quantity Of 2 Plastic Washer	L  Quantity Of 1 Chair wood Back
M  Quantity Of 2 Allen Wrench	N  Quantity Of 4 Nut	

T BAR STOOL

Assembly Instruction

STEP 1.

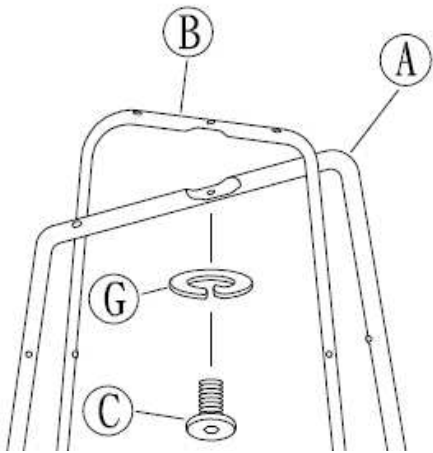

STEP 2.

Arrows point to front of seat.

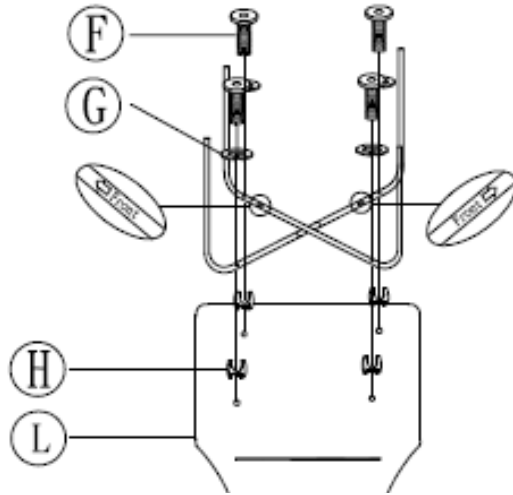

STEP 3.

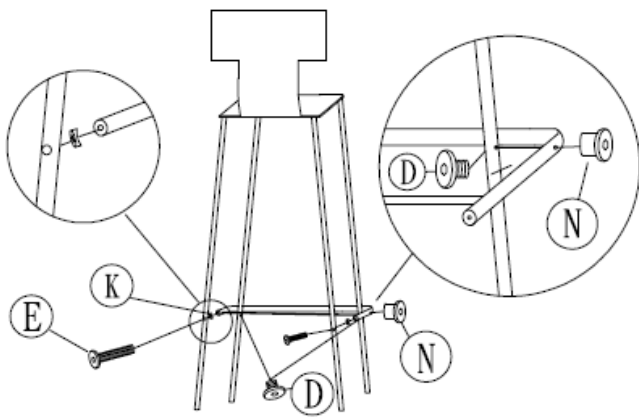

STEP 4.

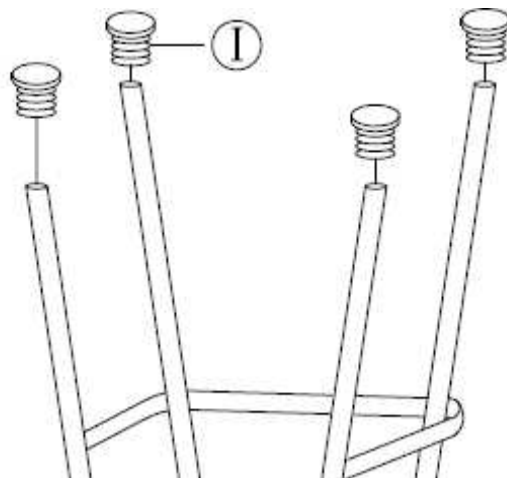

STEP 5.

