

# 3' CLIFTON GUEST BED

1. Please read through and follow the step by step instructions in the leaflet.
2. We recommend that assembly is done in the room intended for use and it is assembled by two adults.
3. Please do not discard any packaging before you have checked all the parts and fittings are complete.
4. Assemble this product on a flat and clean surface to avoid scratching.
5. Do not fully tighten all bolts until all parts have been assembled loosely. Product and/or fittings might be damaged by over tightening screws or bolts. Beware of cross-threading the screws and nuts during assembly.
6. Keeps fittings away from children's reach.

Can you please add the below additional disclaimers that our customer would like to be added to Assembly Instructions:

- o Wipe clean using a soft damp cloth followed by a dry cloth.
- o Do not use abrasives or cleaning products which may contain ammonia or solvents.
- o Take care when handling or moving the furniture. Careless handling can damage wooden furniture, try to lift rather than drag

**SAFETY WARNING:** Do not stand on the bed base without a mattress in place.

## PARTS LIST

(A)-Headend



(B)-Footend

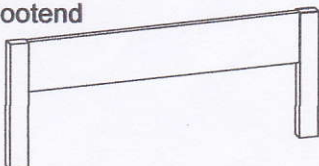

(C)-Siderail x 2pcs



(D)-SideRail (S) x 2pcs

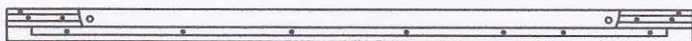

(E)-Support Rail x 2pcs

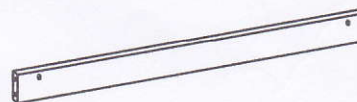

(F)-Headend and Footend Panel (Trundle) x 2pcs



(G)-Side Plastic Slat Holders x 52pcs



(H)-Wooden Slat x 26pcs



(I)-Center Metal Rail x 2pcs



## FITTINGS

1. JCBB M8 x 20mm x 8 pcs



4. M5 Allen Key x 1 pc



7. JCBC M6 x 60mm x 8 pcs



10. CSK Screw M4 x 32mm x 4 pcs



2. M8 Flat Washer x 8 pcs



5. Dowel M10 x 30mm x 12 pcs



8. Barrel Nut M6 x 8 pcs



11. Wood Button x 4 pcs



3. M8 Spring Washer x 8 pcs



6. M4 Allen Key x 1 pc



9. Swival Castor x 4 pcs



**Step 1 :** Attach the Siderails (C) to the headend (A) and Footend (B) by using JCBB M8 x 20mm (1) and M8 Spring Washer (3) and M8 Flat Washer (2) tighten using M5 Allen Key (4).  
 Fix the Centre Metal Rail (I), to the Side Rail L & R (C) with CSK Screw M4 x 32mm (10)  
 Tighten using screw driver.

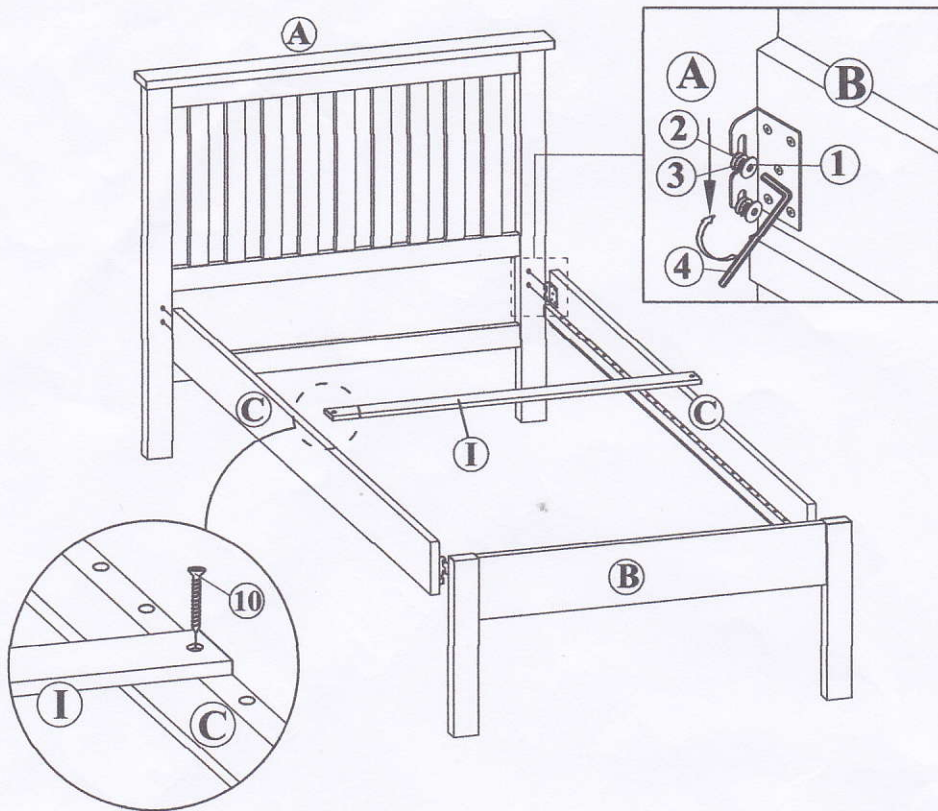

**Step 2 :** Insert the Swival Castor (9) into Siderail (D) as shown in below.

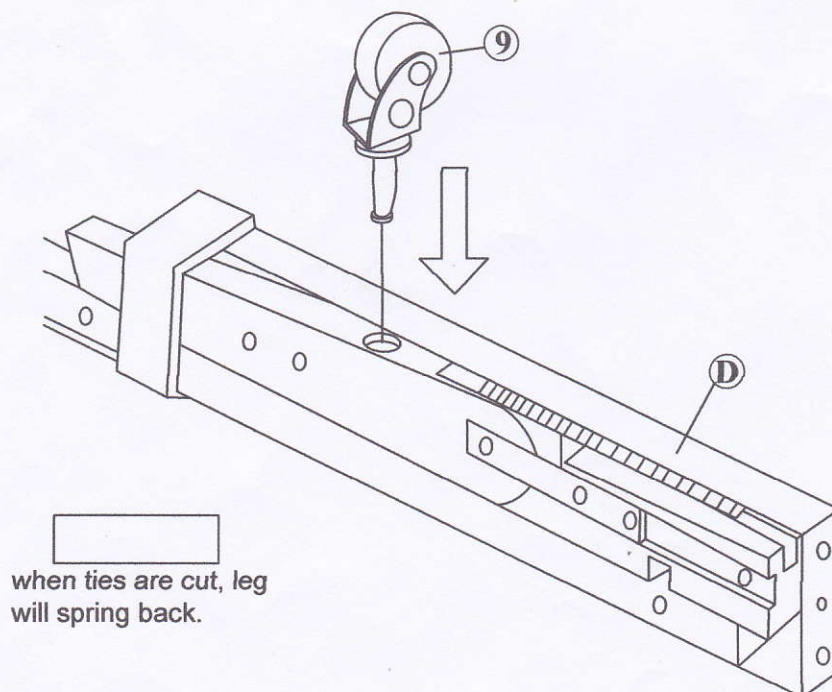

**Step 3 :** Insert Wood Dowel (5) into the pre-drilled hole of Support Rail (E). Attach the Siderail (D) to the Support Rail (E) and secure in place with Allen Bolt M6x60mm (7) and Barrel Nut M6 (8). Tighten using Allen Key M4 (6).

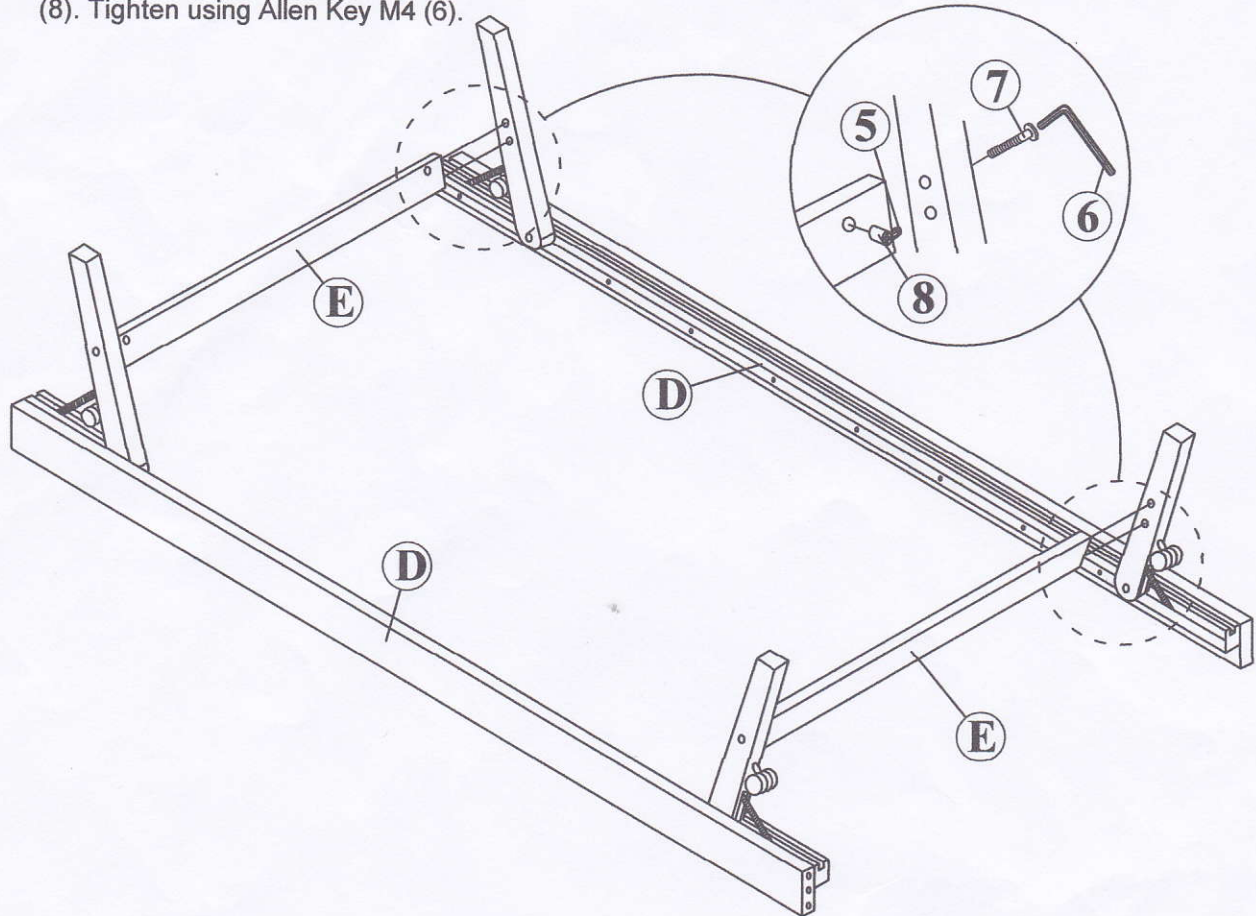

**Step 4 :** Insert Wood Dowel (5) to the pre-drilled hole of Siderail (D). Attach the Siderail (D) to the Headend and Footend Panel (Trundle) (F) and secure in place with Allen Bolt M6x60mm (7) and Barrel Nut M6 (8). Tighten using Allen Key M4 (6). Insert Wood Button (11) to the Headend and Footend Panel (Trundle) hole.

(F)-Headend and Footend Panel (Trundle) x 2pcs

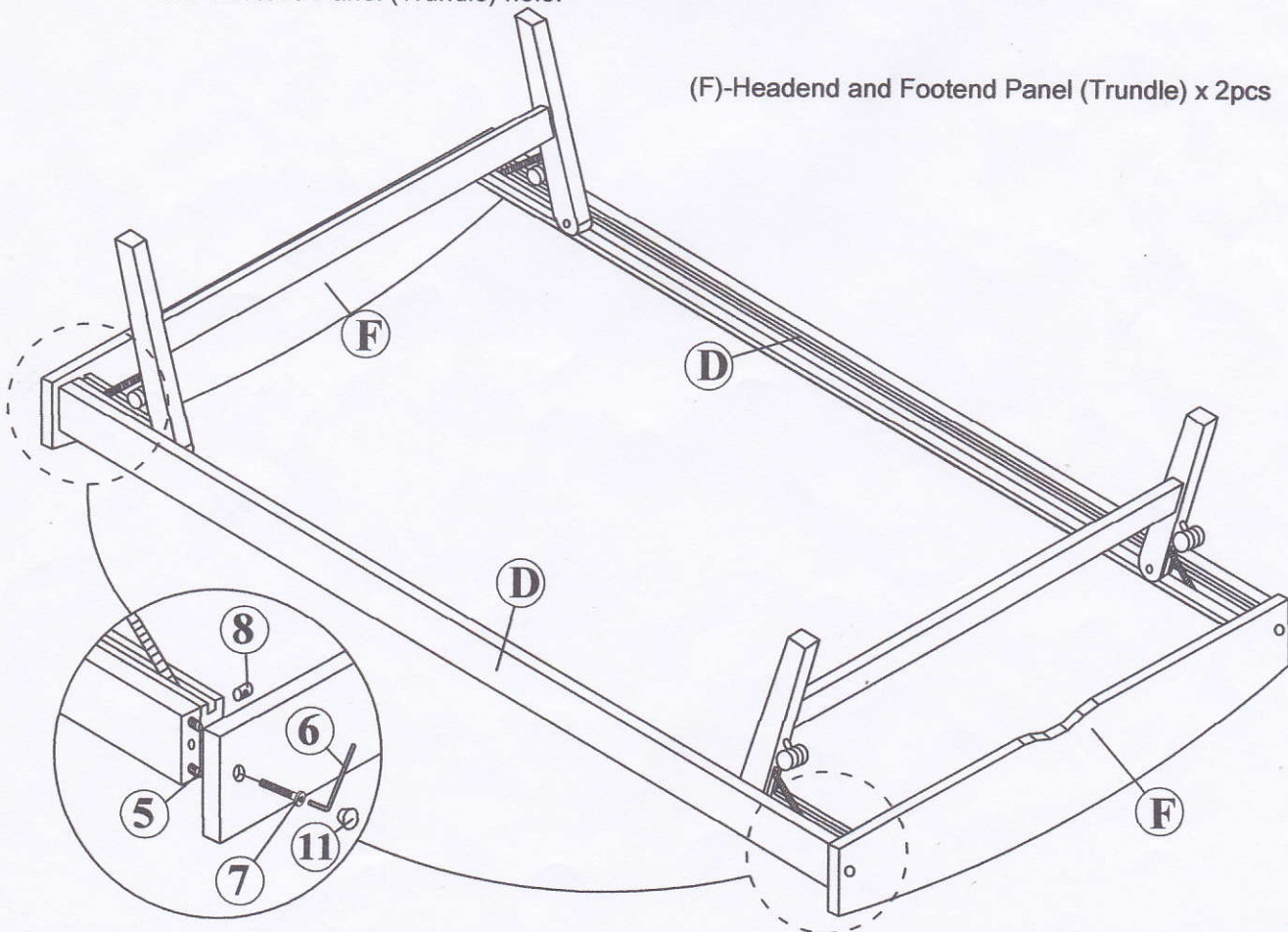

**Step 5 :** Insert the Wooden Slat (H) into the Plastic Slat Holders (G) as shown.

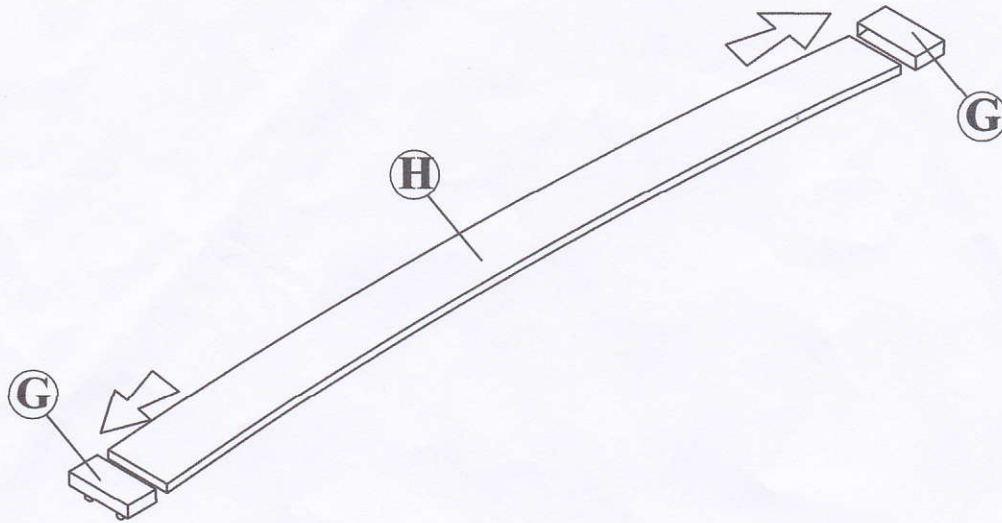

**Step 6 :** Fix the Centre Metal Rail (I), to the Side Rail (D) with CSK Screw M4 x 32mm (10)  
Tighten using screw driver.

Align the pin on Plastic Slat Holders (G) to the holes along the Side Rail (C) (D).  
Gently tap them into the holes. Tap the corner of the Plastic Slat Holder (G) to knock them  
into place with rubber mallet. ( **NOT** provided )

