



Birlea

Suppliers of inspiration

Vendor: S000053



ASSEMBLY INSTRUCTIONS **POPPY 3' BED**

IMPORTANT: READ THESE INSTRUCTIONS CAREFULLY BEFORE ATTEMPTING TO ASSEMBLE OR USE YOUR POPPY 3' BED FRAME

PLEASE KEEP THESE INSTRUCTIONS FOR FUTURE REFERENCE

HEALTH & SAFETY:

DO NOT jump on this bed frame

DO NOT use this bed frame if any parts are missing, damaged or worn

DO NOT use this bed frame unless all fixings are secured

Always use on a level, even surface

WARNING: If this bed is placed on a laminated floor you must place some protection under all legs to stop the bed frame from moving. If this is not adhered to there is no guarantee if the bed frame collapses

CARE & MAINTENANCE:

Periodically check all screws & fixings to ensure they are secure

DO NOT push the bed frame as this will damage the legs

Always lift the bed with two people to reposition

Keep any sharp objects away from the frame



www.birlea.com

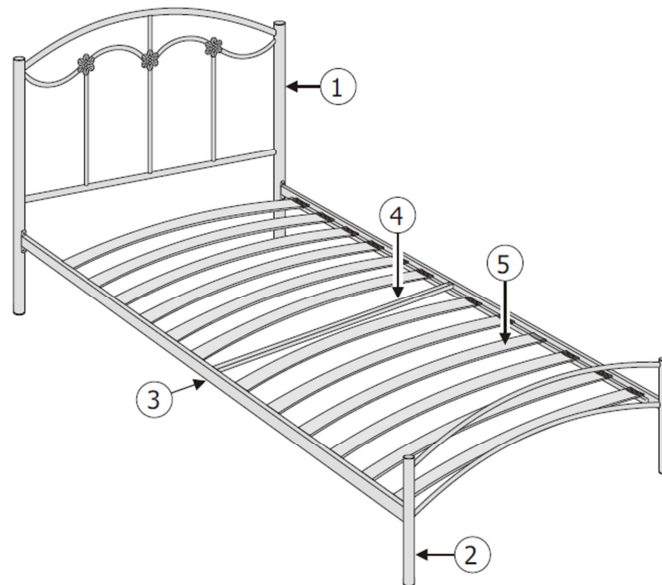

Parts List			Hardware List		
Part	Description	Qty	Part	Description	Qty
1	Headend	1	A	M6 x 16 mm JCBC Screw	8
2	Footend	1	B	M6 x 45 mm JCBC Screw	2
3	Side Support	2	C	M6 Nut	2
4	Mid Support	1	D	Slat Cap	24
5	Slat	12	** M4 Allen Key provided		

Step 1: Fix the side support (3) to the headend (1) and footend (2) using hardware part A but do not fully tighten yet

DO NOT use any power tools as this may damage the frame and will invalidate any claim

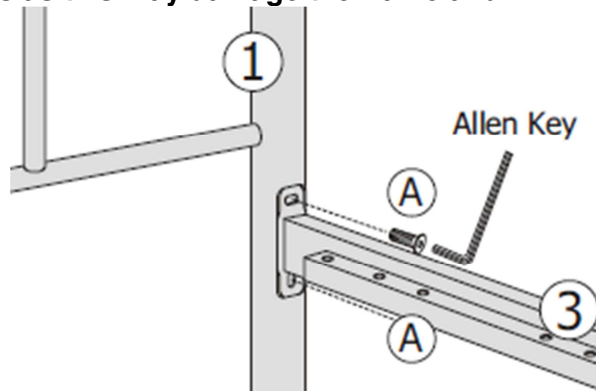

Step 2: Place the mid support (4) on top of the side supports (3) and tightly secure using hardware parts B and C

DO NOT use any power tools as this may damage the frame and will invalidate any claim

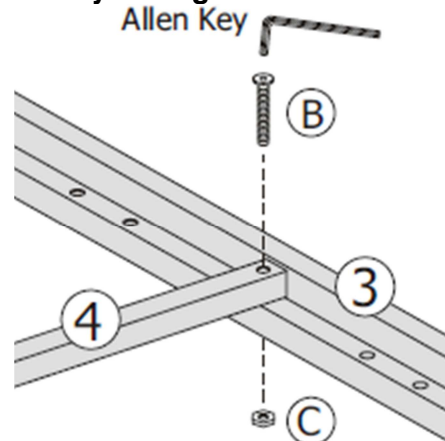

Step 3: Slot hardware part D onto every end of each slat (5), then press firmly into the side supports (3)
DO NOT use any power tools as this may damage the frame and will invalidate any claim.

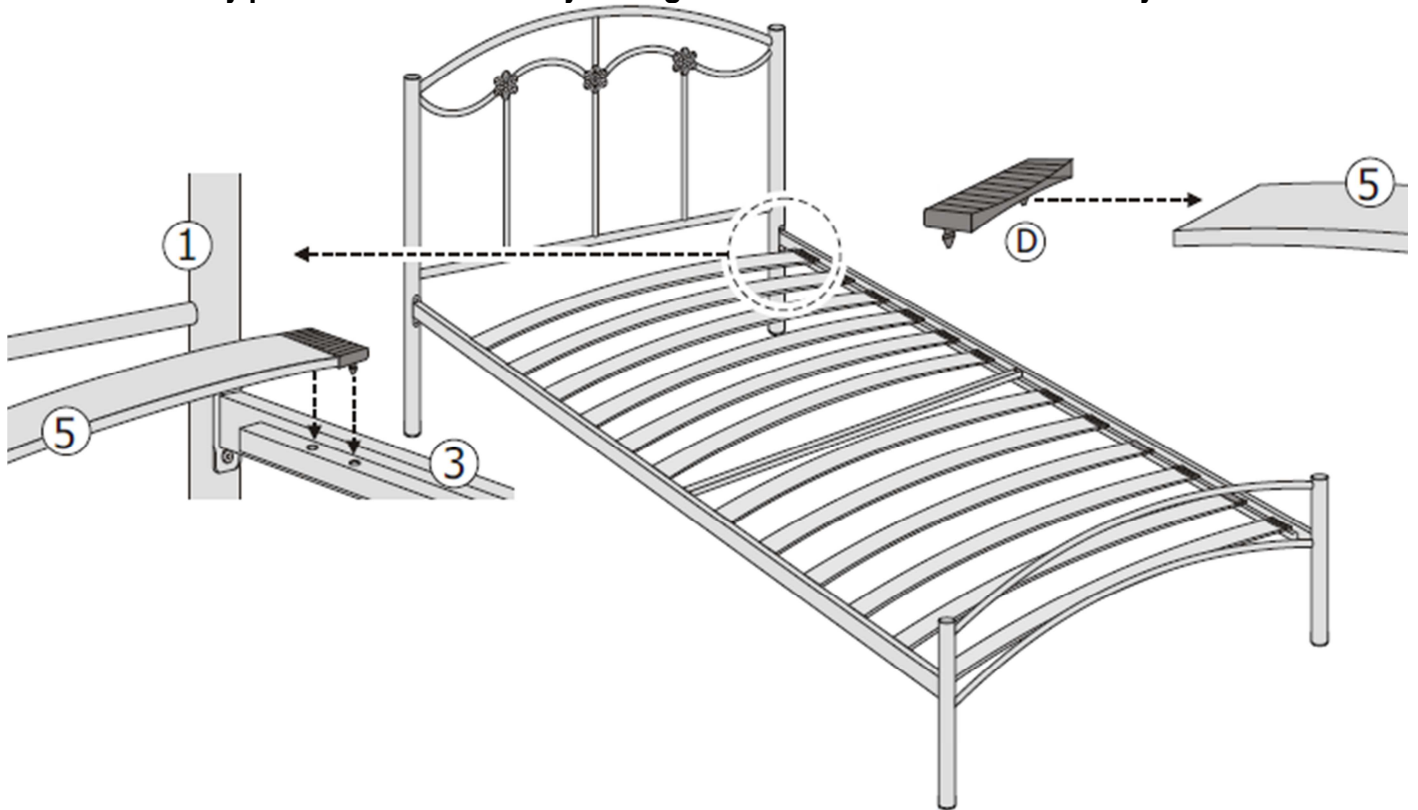

For complete product information, images and dimension diagrams please visit www.birlea.com

