



Birlea

Suppliers of inspiration

Vendor: S000053



ASSEMBLY INSTRUCTIONS **ELEANOR 4' BED**

IMPORTANT: READ THESE INSTRUCTIONS CAREFULLY BEFORE ATTEMPTING TO ASSEMBLE OR USE YOUR ELEANOR 4' BED FRAME

PLEASE KEEP THESE INSTRUCTIONS FOR FUTURE REFERENCE

HEALTH & SAFETY:

DO NOT jump on this bed frame

DO NOT use this bed frame if any parts are missing, damaged or worn

DO NOT use this bed frame unless all fixings are secured

Always use on a level, even surface

WARNING: If this bed is placed on a laminated floor you must place some protection under all legs to stop the bed frame from moving. If this is not adhered to there is no guarantee if the bed frame collapses

CARE & MAINTENANCE:

Periodically check all screws & fixings to ensure they are secure

DO NOT push the bed frame as this will damage the legs









Always lift the bed with two people to reposition

Keep any sharp objects away from the frame



www.birlea.com



Parts List			Hardware List		
Part	Description	Qty	Part	Description	Qty
1	Headend	1	A	M6 x 16 mm JCBC Screw 	8
2	Footend	1	B	M6 x 50 mm JCBC Screw 	4
3	Side Support	2	C	M6 Nut 	10
4	Side Frame	2	D	M6 x 35 mm JCBC Screw 	6
5	Mid Support	1	E	Double Slat Cap 	11
6	Base Leg	3	F	Single Slat Cap 	22
7	Slat	22	G	M8 x 50 mm JCBC Screw 	2
** M4 Allen Key and M5 Allen Key provided			H	M8 Nut 	2

Step 1: Fix the side support (3) to the headend (1) and footend (2) using hardware part A but do not fully tighten

DO NOT use any power tools as this may damage the frame and will invalidate any claim

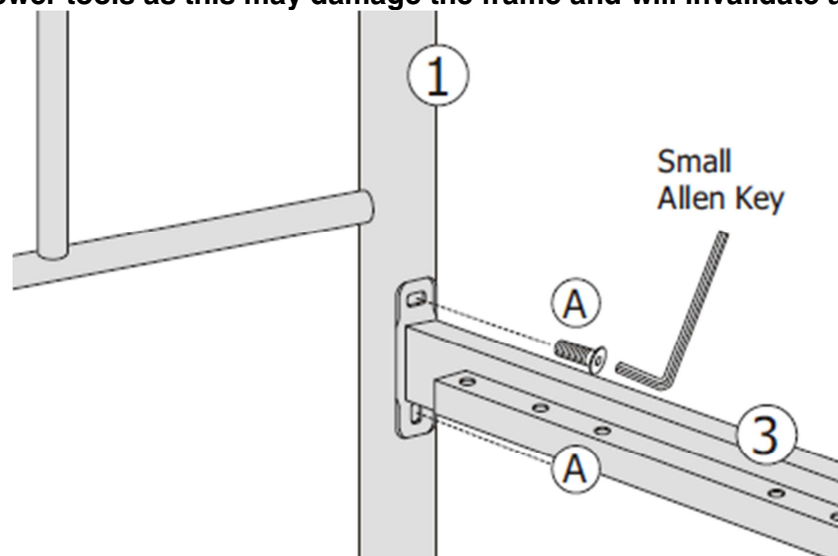

Step 2: Place the side frame (4) at the bottom of the side support (3) and secure using hardware parts B and C

DO NOT use any power tools as this may damage the frame and will invalidate any claim

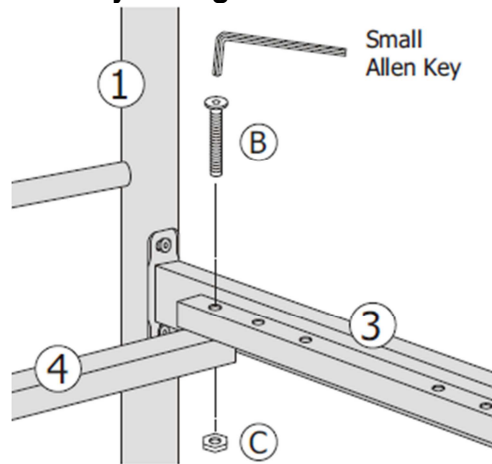

Step 3: Place the mid support (5) on top of the side frames (4) and tightly secure using hardware parts H and G

DO NOT use any power tools as this may damage the frame and will invalidate any claim

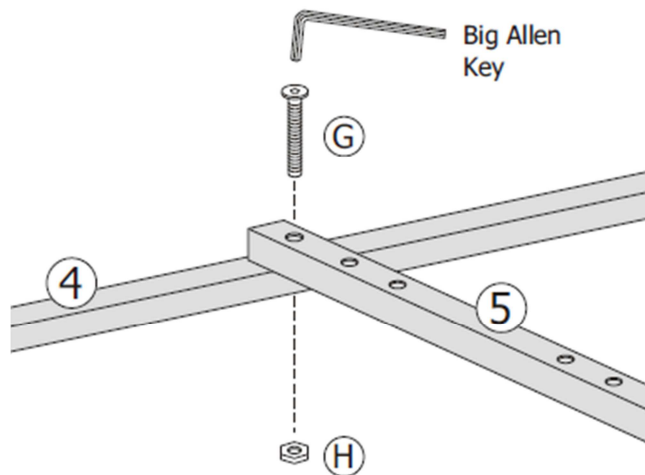

Step 4: Take the base leg (6) and fit to the mid support (5) according to the holes at the side using hardware parts C and D

DO NOT use any power tools as this may damage the frame and will invalidate any claim

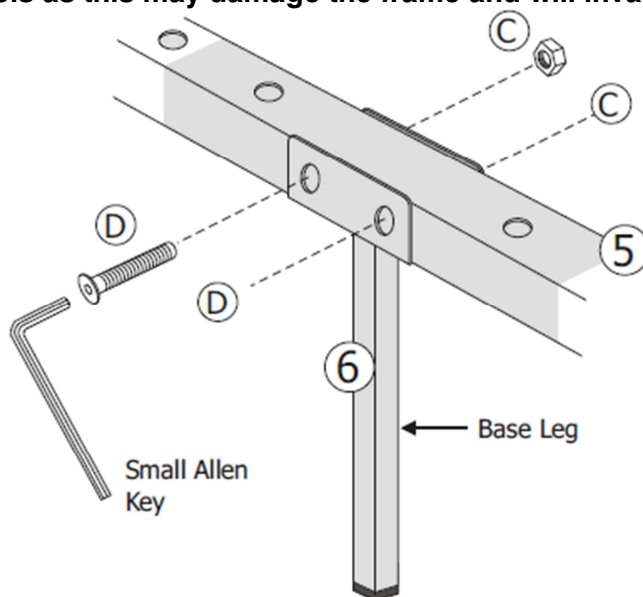

Step 5: Push hardware parts E into the mid support (5) then place hardware part F onto each slat (7).
DO NOT use any power tools as this may damage the frame and will invalidate any claim

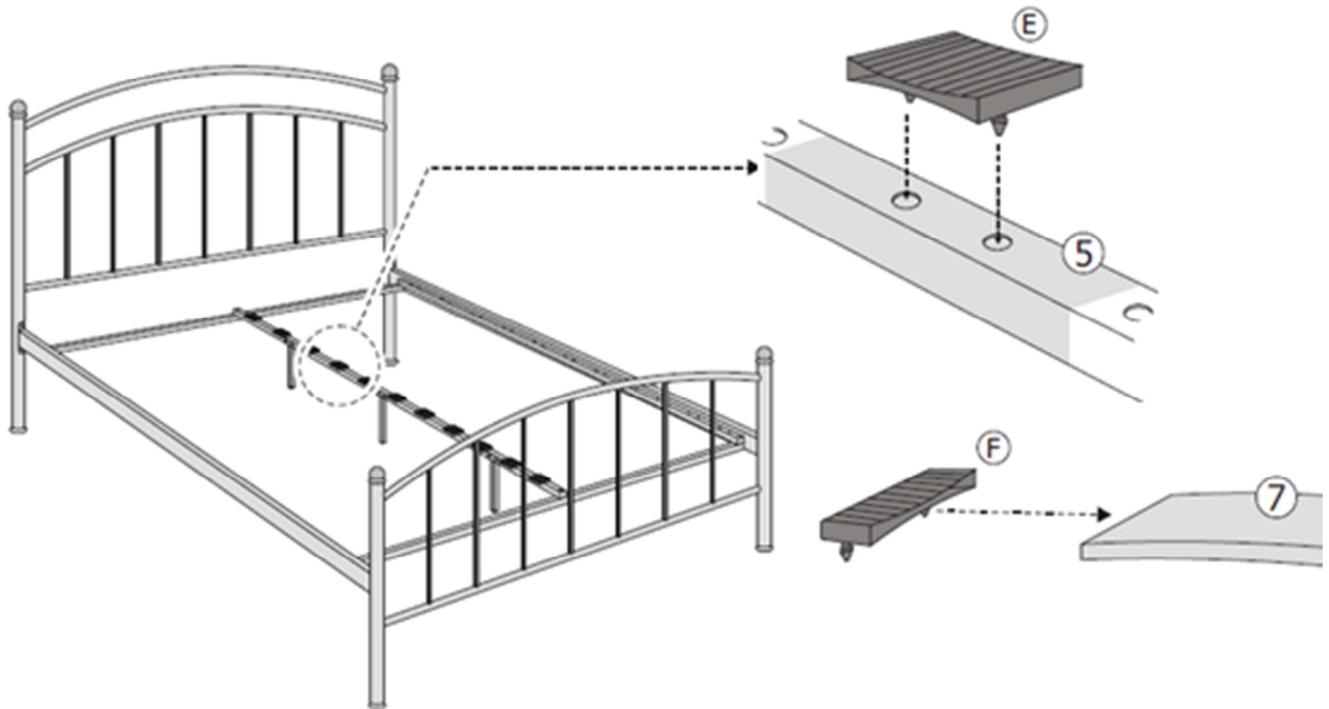

Step 6: Slide the slats (7) into hardware part E on the mid support (5) then push the ends into the side supports (3) firmly

DO NOT use any power tools as this may damage the frame and will invalidate any claim

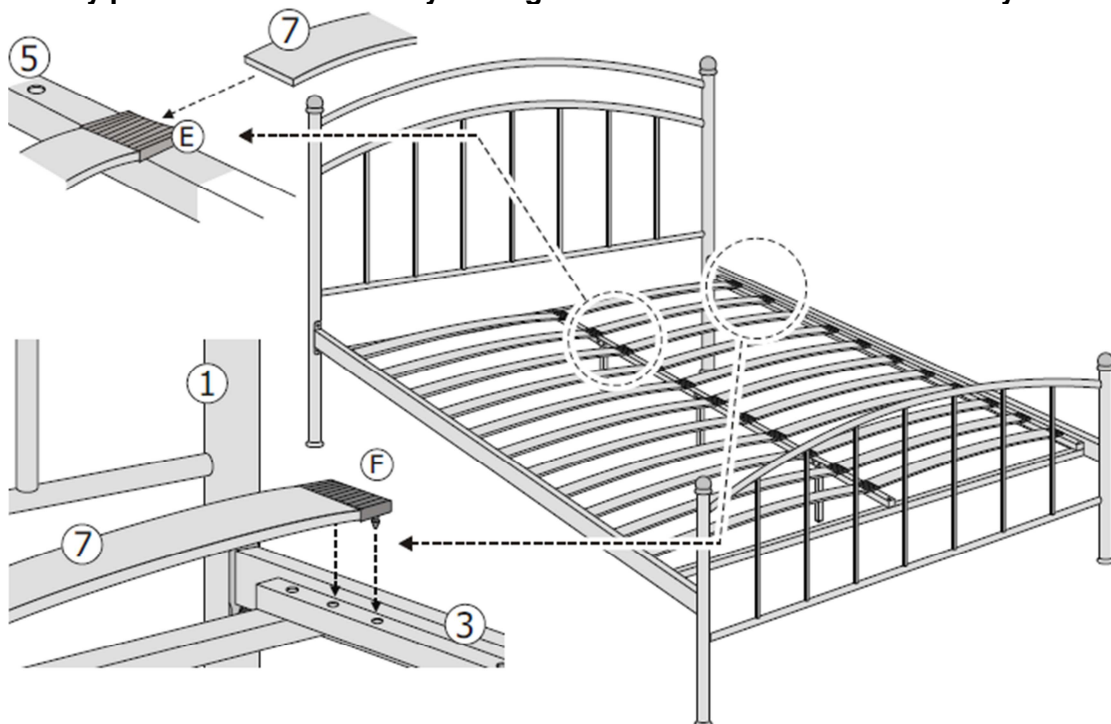

For complete product information, images and dimension diagrams please visit www.birlea.com