

## CL Leg

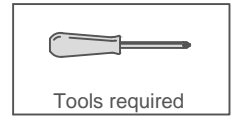

**Please read before assembling the product**



Carefully open packaging.

Check you have all the components shown on instructions sheets. Some products, instructions and fittings are packed in more than one box.

Handle Panels with care. Complete each stage before going to the next one.

Please keep packaging until assembly is complete. We hope that you are happy with the product.



Please recycle packaging



Keep fittings away from children



No power tools when inserting cam pins



No power tools when tightening cams



**If you have-**

**P2**

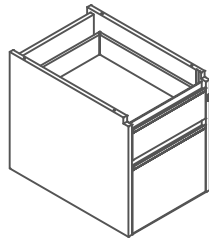

**P3**

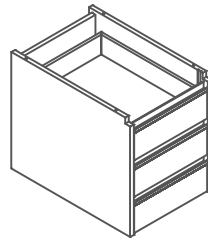

**Use instructions inside**

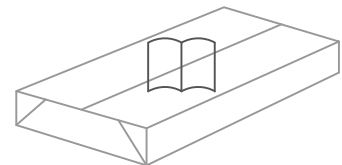

**P2 or P3 Box**

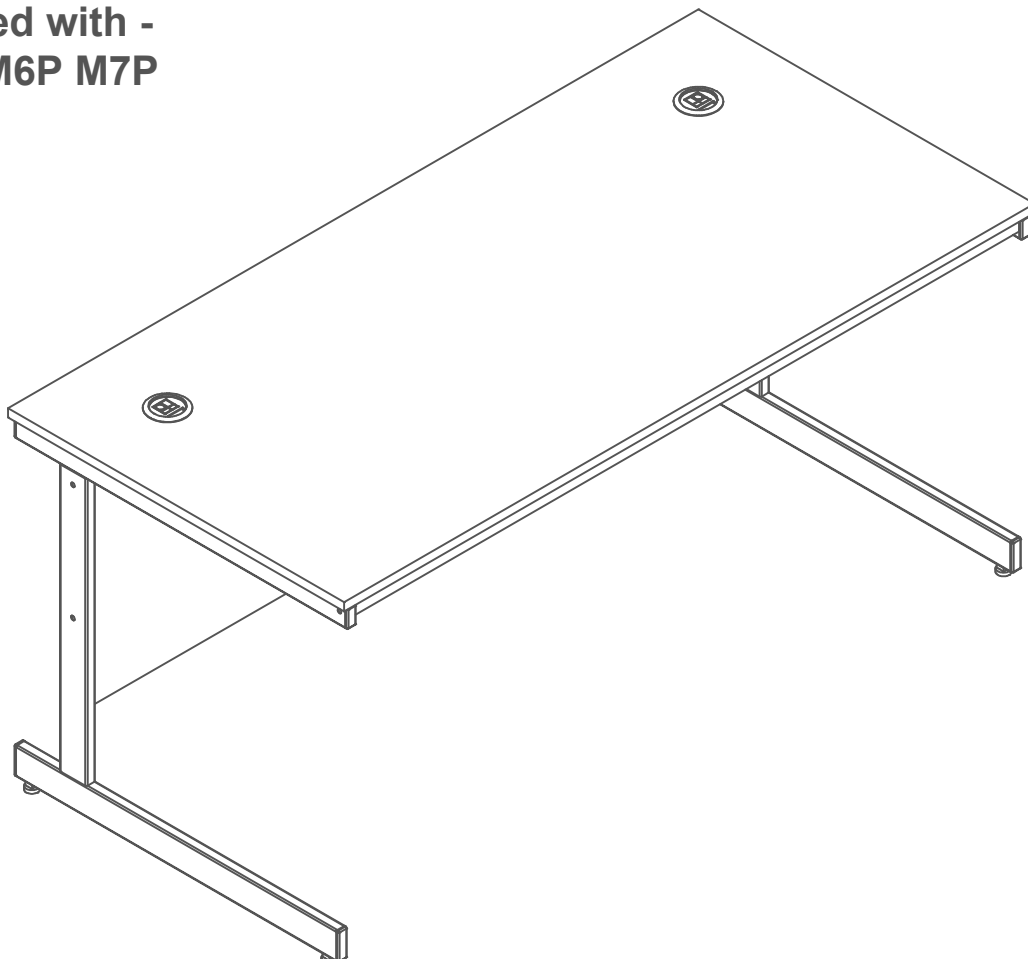

**CL Leg used with -  
M3P M4P M6P M7P**







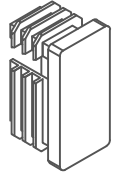

Please check that you have all the fittings

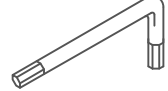

CL	
4	Ferrul 40x20mm with cut out RM-FRL05 
4	Ferrul 60x20mm RM-FRL02 

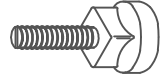
M3P M4P M6P M7P	
4	Confirmat screw 70mm RM-CFM02 
2	Connect Bolt M6x50mm RM-BLT05 
4	<b>! 2</b> M3P 1 1/2" x 8 screw RM-SCR11 
1	4mm Allen key RM-ALK01 
2	Blum pin RM-PIN01 
4	Adjustable Foot Dia 25mm RM-FRL19 



Please check that you have all the panels

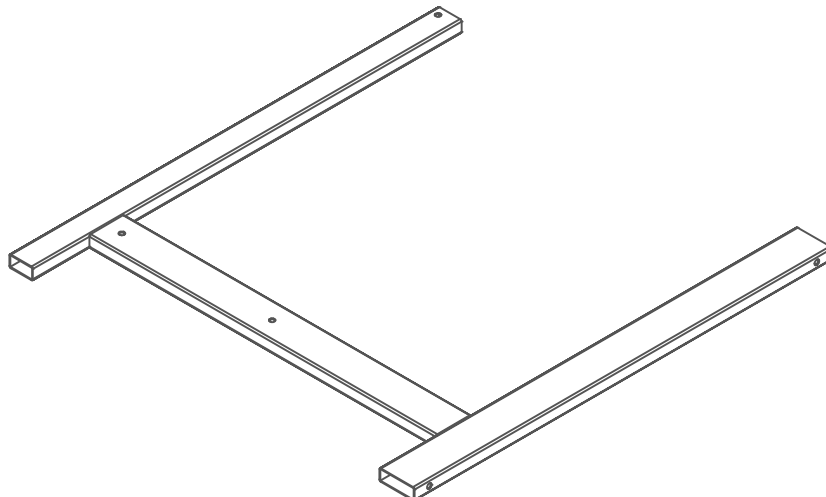
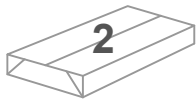
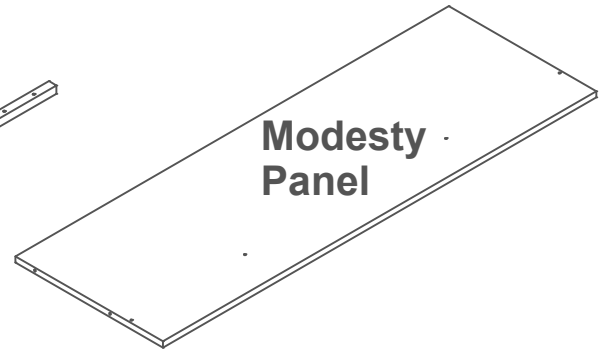
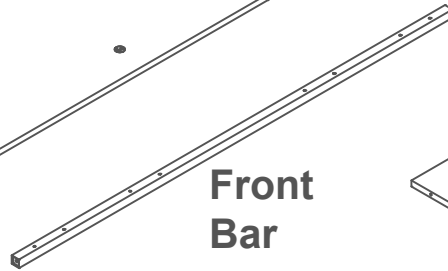
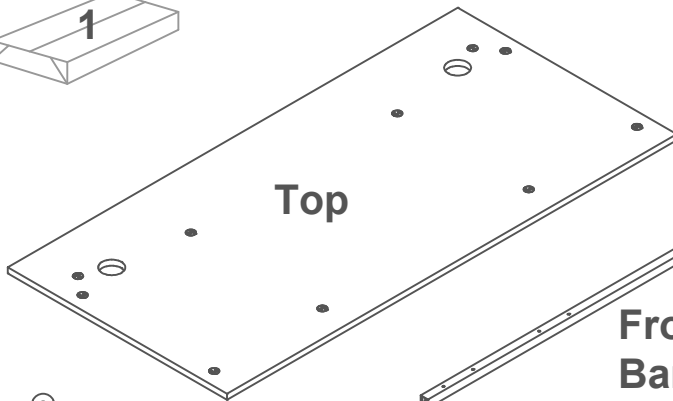
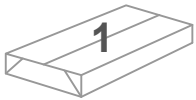

1

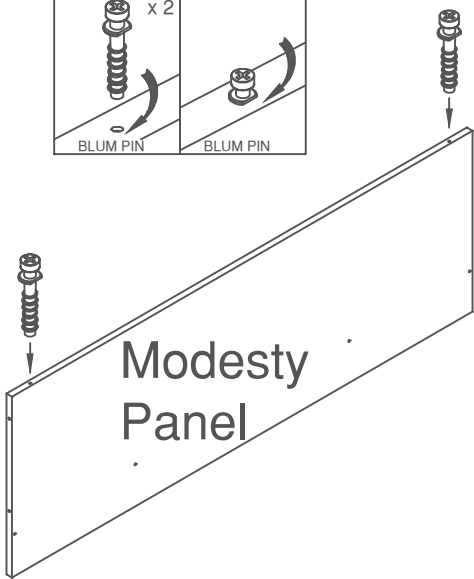
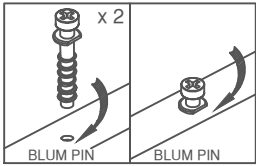

Turn over 180°



Holes to face front of desk

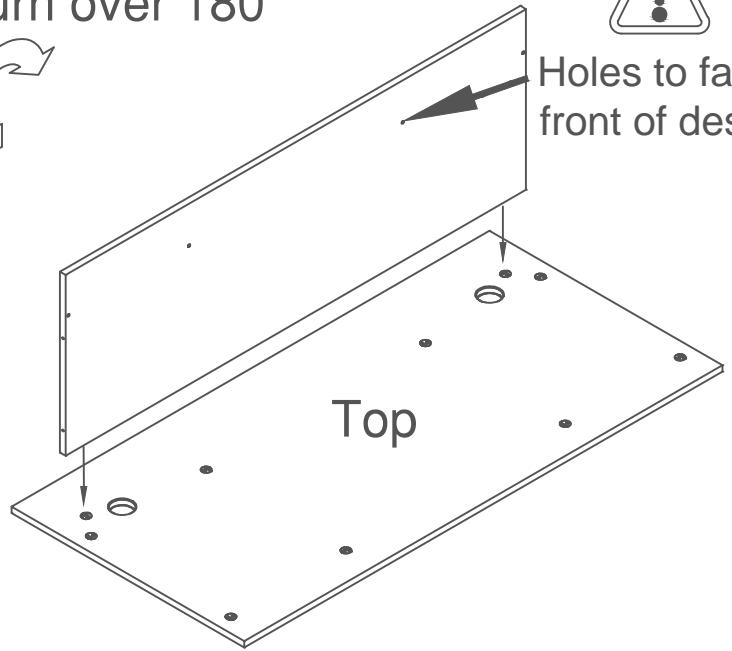

2

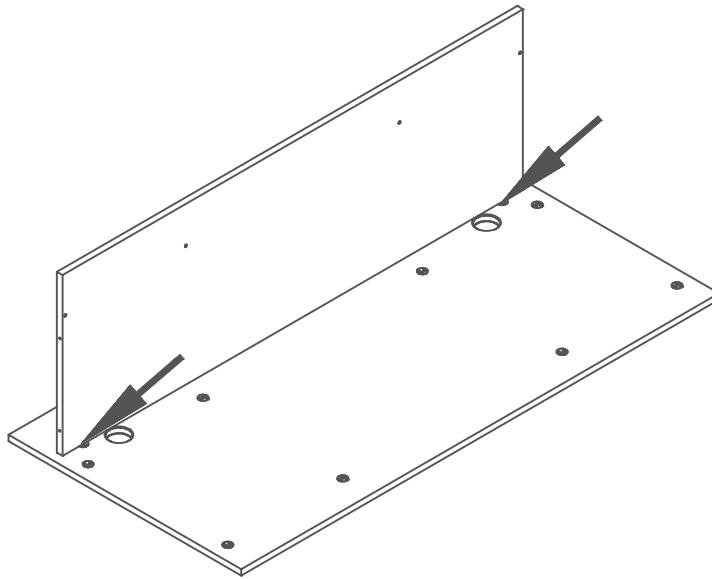
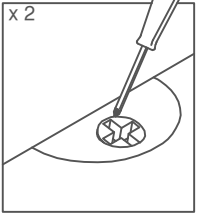

3

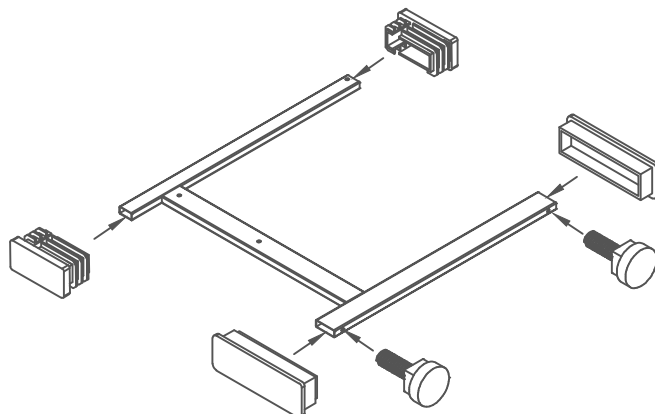
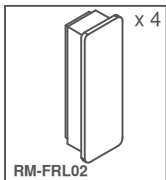
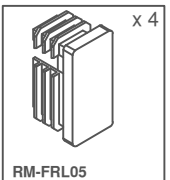

CL (X2 LEGS)

4

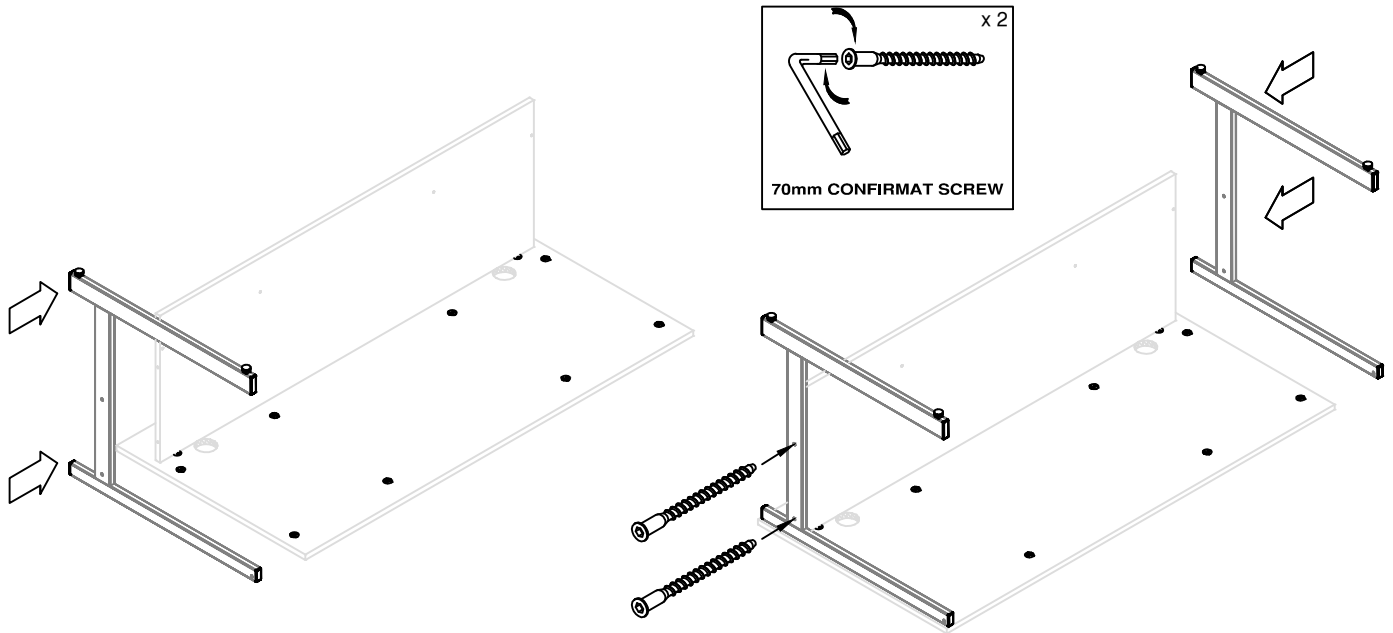

5

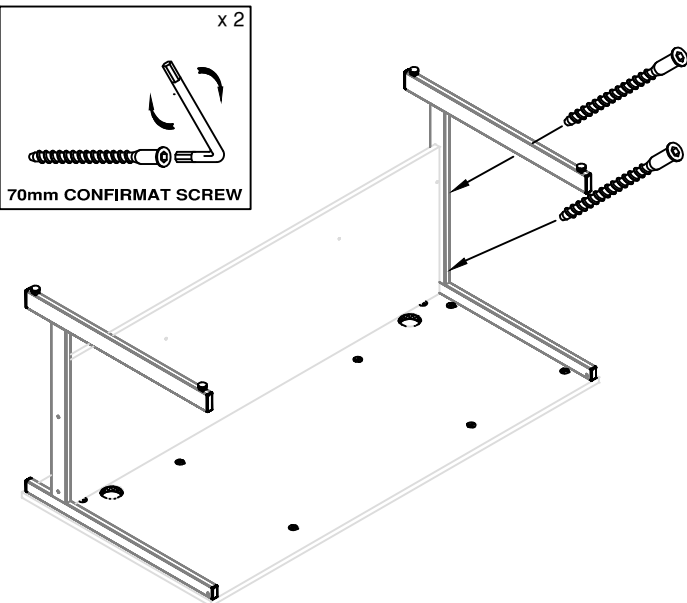

6

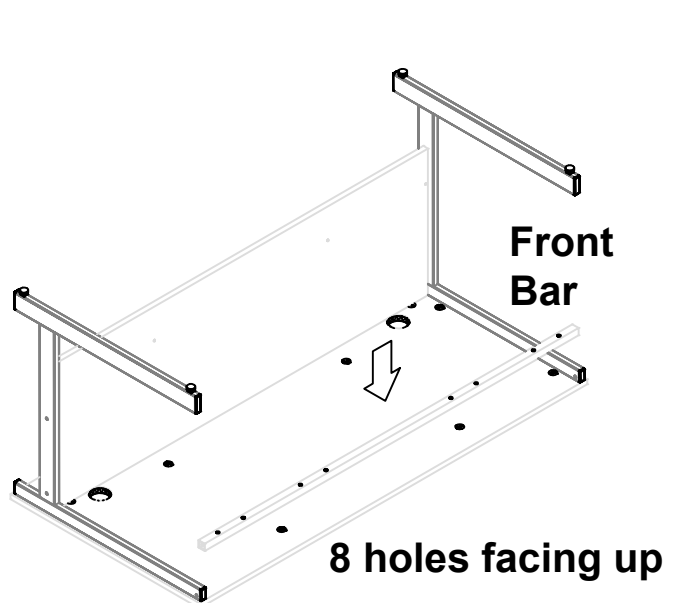

7

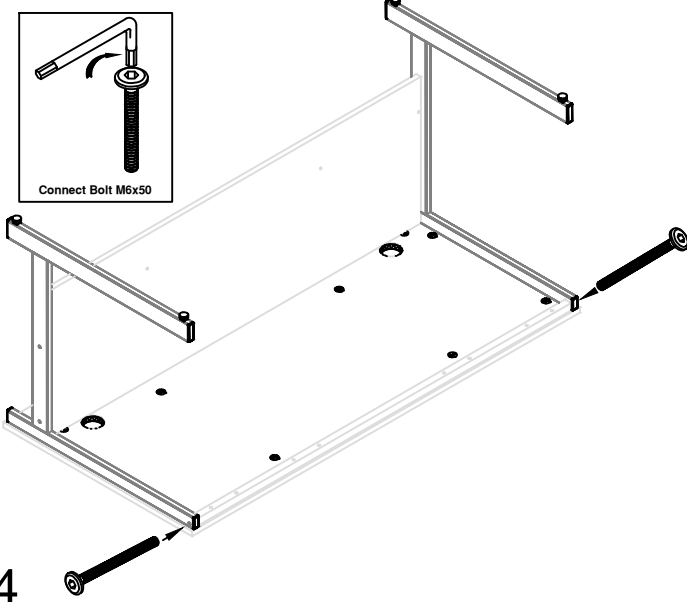

8

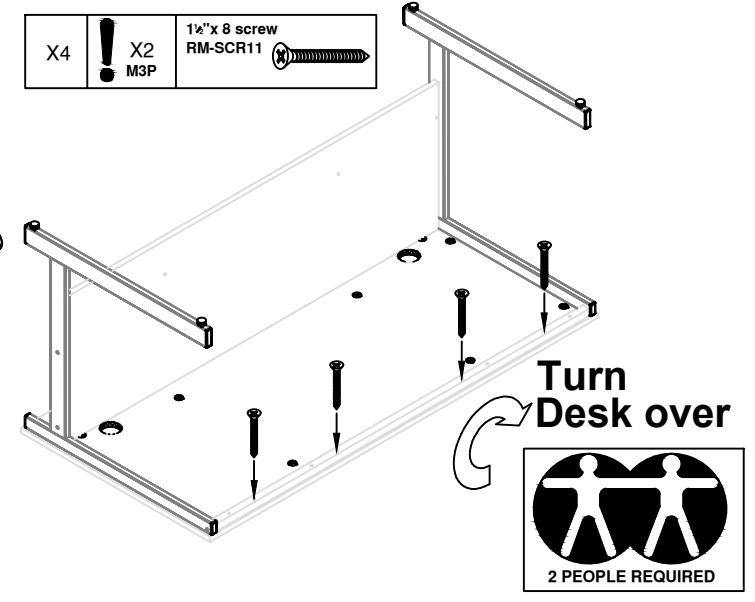

4