



STANDARD
furniture

GRAND DESIGNS

ASSEMBLY INSTRUCTION

GROUP NO. :55650

ITEM NO. :55651

UPHOLSTERED BED

Read instructin carefully prior to assembly.
Thank you for purchasing this quality product.
check carefully for small parts which may have
some loose during shipment.
Remove all components from pack and assemble
near area that bed is to be placed.

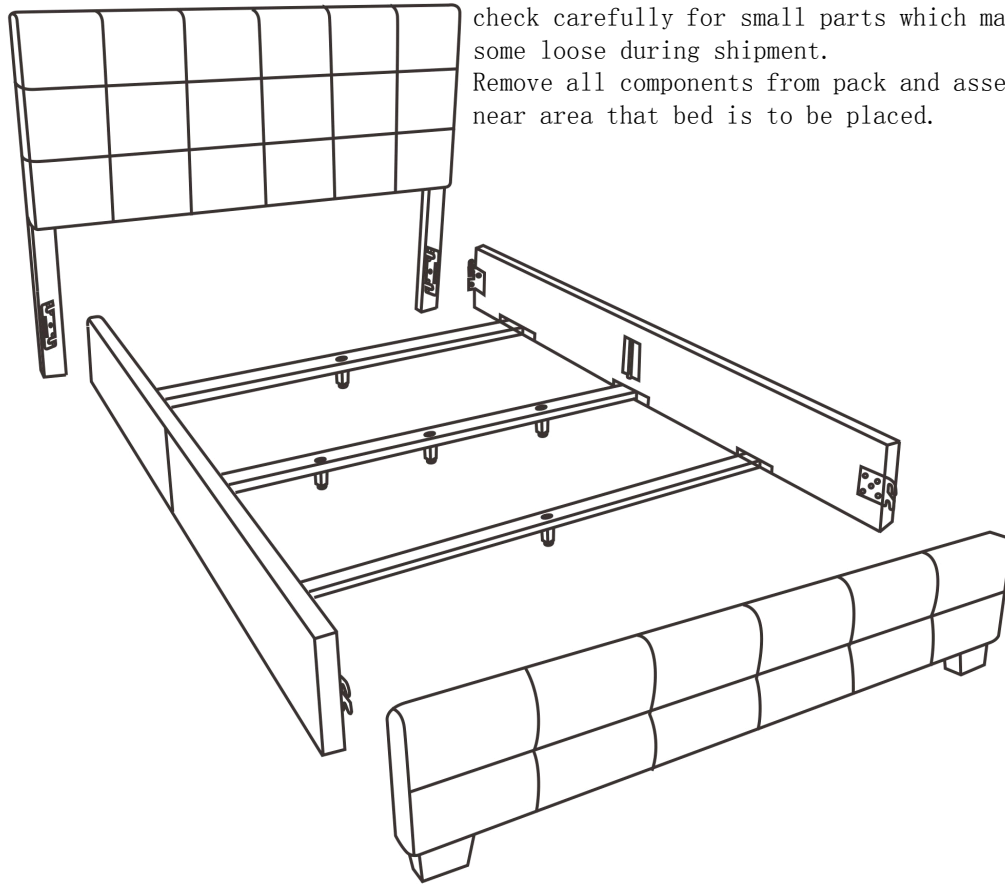

NO	DRAWING	QTY
A		4pcs
B		4pcs
C		2pcs
D		6pcs
E		4pcs55mm
F		6pcs50mm
G		4pcs30mm
H		28pcs20mm 16pcs25mm
I		4pcs30mm
J		5pcs30mm
K		5pcs

PART LIST			
NO.	PART	DESCRIPTION	QTY
1		headboard	1
2		side rail	2
3		foot board	1
4		Support rail	3
5		8mm	1
6		6mm	1

Cleaning instructions:clean using soft cloth

Made in china



STANDARD
furniture

ASSEMBLY INSTRUCTION

GROUP NO. :55650

ITEM NO. :55651

GRAND DESIGNS

UPHOLSTERED BED

Step 1: Attach legs to headboard and footboard using Allen key 5 and 6.

Note: Assembly made easier with use of a power driver, Be sure to tighten screws on each leg equally so legs are attached straight.

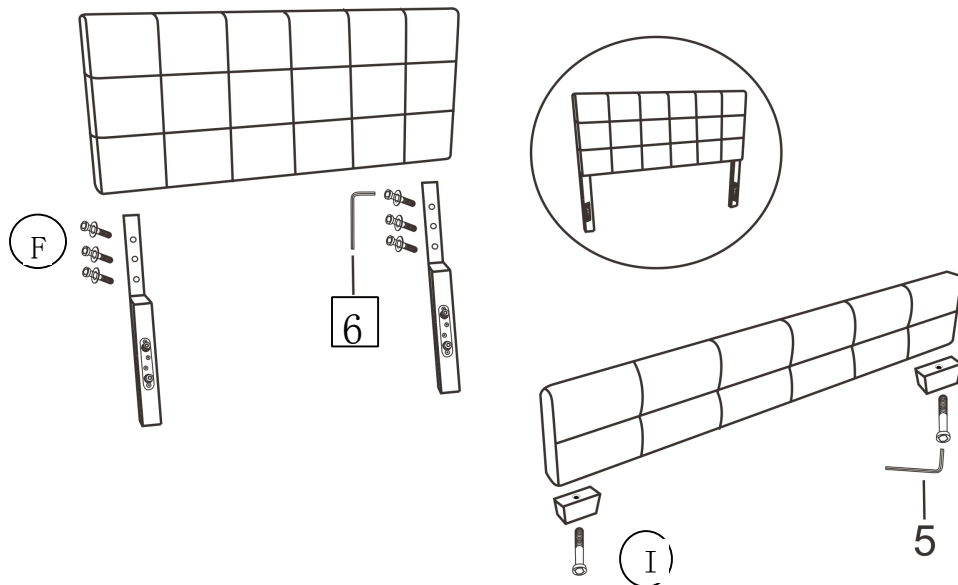

Step 2: Located the hardware (A) in the ends of side rail with bolt (H). Located and tighten U shape (D) with bolts (H) using Allen key 6. Screw adjustable legs (K) to the legs of support rail and tighten them with bolts (J) using Allen key 6.

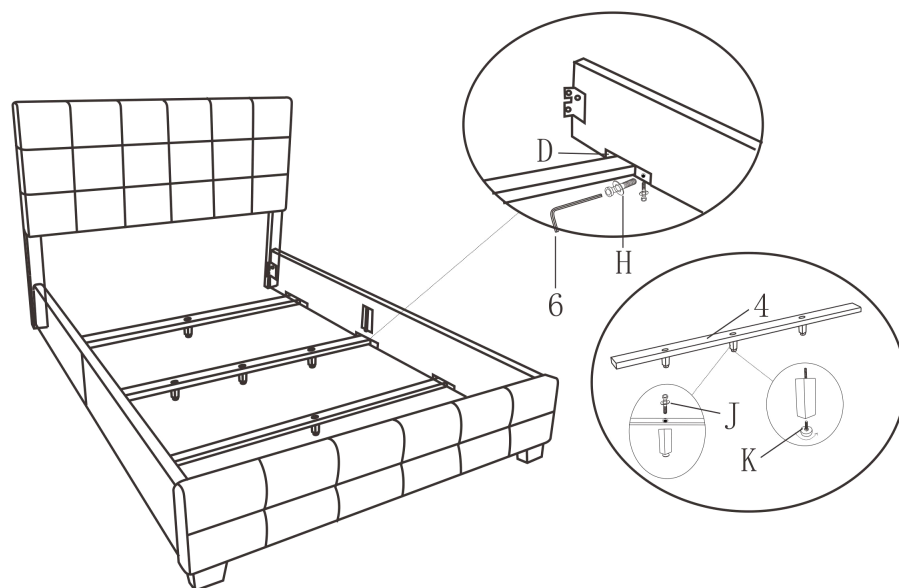

Cleaning instructions: clean using soft cloth

Made in china



STANDARD
furniture

GRAND DESIGNS

ASSEMBLY INSTRUCTION

GROUP NO. :55650

ITEM NO. :55651

UPHOLSTERED BED

Step 3: located bolts(E) on headboard and bolts(G) foodboard, place side rail into position. Tighten the bolts with Allen key 5

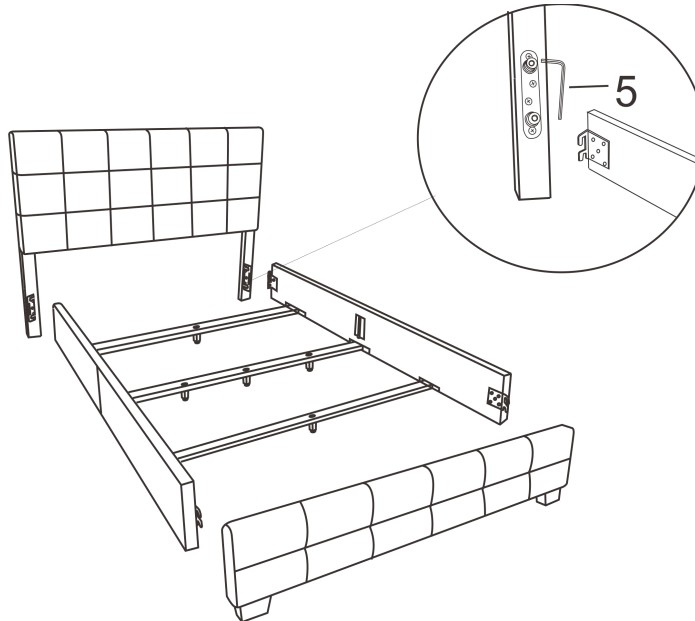

Step 4: Place the three support rail to the U shape, adjust the legs(k) into a same level.

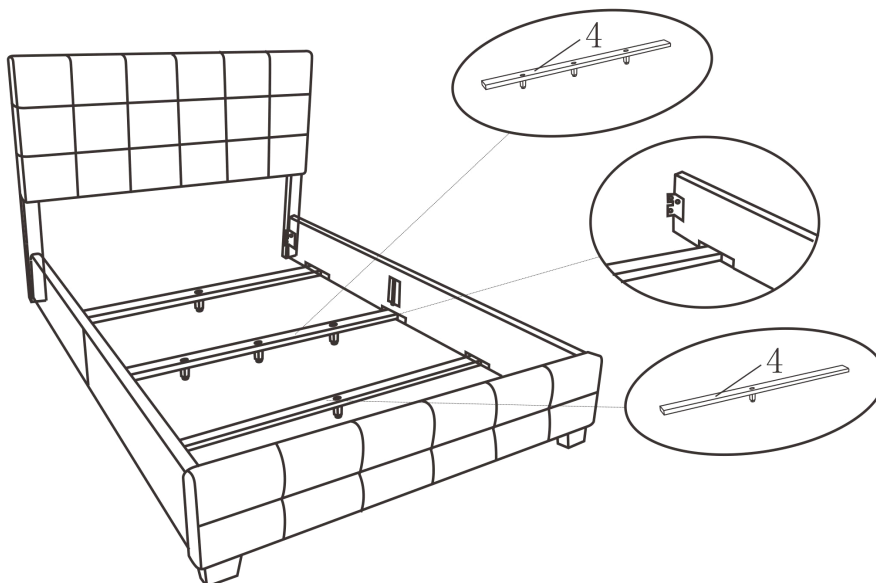

Cleaning instructions: clean using soft cloth

Made in china