



VECTOR ELECTRONIC DARTBOARD



Please keep this instruction manual for future reference

**If you have any problems with your new product,
please contact Triumph Sports USA at 1-866-815-4173,
or e-mail us at csr@triumphsportsusa.com
for any technical support or warranty issues.**

Limited 90-Day Triumph Sports USA, Inc. Warranty

All Triumph Sports USA, Inc. (TSU) games have a limited 90-day from date of purchase warranty. This warrants the retail purchaser for any TSU game purchased to be free from any defect in materials and construction for 90 days from the date of purchase. The only exceptions to the warranty include main frames, tabletops, playing surfaces, batteries or tools. Damaged main frames, tabletops, playing surfaces need to be returned to the store as we are unable to replace these parts. Normal play wear and usage is not covered under the warranty, nor is wear or damage due to improper use of the TSU game. This will void any and all TSU warranties.

A PURCHASE RECEIPT (or other proof of purchase date) will be required before any warranty service is initiated. All requests for warranty service can be submitted by email, in writing or by contacting our Customer Service Department at: 1-866-815-4173 or email us at csr@triumphsportsusa.com.

Warnings



WARNING:Choking Hazard--Toy contains small balls and/or small parts. Not for children under 3 years of age.



WARNING:this is not a child's toy. adult supervision is required for children playing darts. proper use of darts can prevent damage or injury.

Be sure to check out all the exciting games  has to offer.

Visit our web site at:

www.triumphsportsusa.com



BILLIARDS



DARTS



GAME TABLES



CASINO



OUTDOOR GAMES



DARTBOARDS

Triumph Sports USA
11327 W Lincoln Ave.
West Allis, WI 53227
www.triumphsportsusa.com

©2014 Triumph Sports USA. All Rights Reserved.

Batteries

This dartboard requires 3 AAA (1.5 volt) Batteries to operate. BATTERIES NOT INCLUDED. Do NOT mix old and new batteries and do not mix alkaline, standard (carbon zinc), or rechargeable (nickel cadmium) batteries.

Do not dispose of batteries in fire, batteries may explode or leak.

Parts List

Mounting Instructions

Choose a location to hang the dartboard where is about 10 feet (3.048 m) of open space in front of the board. The “toe-line” should be 7’9 1/4” (2.37 M) from the face of the dartboard for steel tip rules or 8 feet for soft tip rules. You will need to mount the board close to an electric outlet if your dartboard requires an AC adapter. Always remove the batteries when you use an adapter. Regardless if the dartboard has horizontal or vertical hang hole(s), the center of bullseye should be 5’8” (1.73 m) from the ground when mounted. (Figure A) Make a small temporary reference mark on the wall at 5’8 inches from the floor. (do not drill a hole in the temporary reference mark) Measure the distance between the top hang hole on the back of your board and the center of the back of your dartboard. The center of the back of the dartboard is the middle point of the circle area on the back of the board. Take a ruler and determine that distance. Then make the mark for the top hang hole on the wall above the 5’8 mark by the distance you just measured. (see Figure B) Drill the screw into the mark you made. Mount the dartboard on the wall by lining up the hang hole on the back with the screw. It may be necessary to adjust the screws until the board fits snugly against the wall. If you want to mount the dartboard even more securely to the wall, you can utilize the bottom hang holes located on back of the board as well. You will need to make another temporary reference mark 12.54 inches below the top hang hole you drilled. Then make a mark 5.31 “ to the left and another mark 5.31” to the right of the temporary mark for the additional screw locations. Drill the screws into the two marks you made.

Figure A

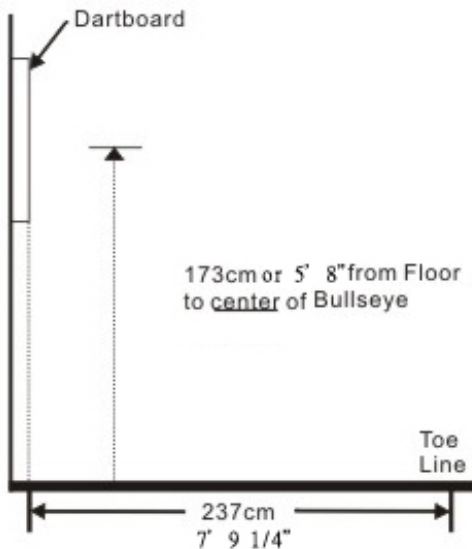
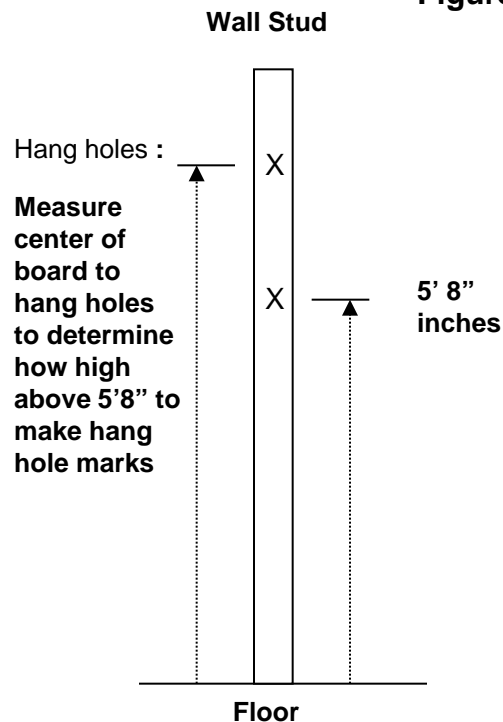

Figure B



Dartboard Functions

POWER button - Press to turn game on or off. Dartboard has an automatic suspend mode to conserve power and battery life (if using batteries). The dartboard will make sound effect and display "SLEEP" on the display after approximately 3 minutes of non-use. However, the scores are stored in memory and can be restored by pressing any button.

START button - This multi-function button is used to:

- START** the game when all options have been selected.
- CHANGE** to the next player when one player is finished with his round.

This will put dartboard in **HOLD** status between rounds to allow player to remove darts from the target area.

GAME buttons - Press to page through the on-screen game menu.

Display Protective Film

This electronic dartboard may have a clear film over the entire display area to prevent scratching during shipping. It is recommended that this film be removed before play to enhance the display area visibility. To remove, simply lift edge, peel off, and discard.

Electronic Dartboard Operation

1. Press the **POWER** button to activate dartboard. A short musical introduction is played as the display goes through power-up test.
2. Press **GAME** buttons until desired game is displayed
3. Press **PLAYER** button to select the number of players (1, 2, 3, 4 , t 2-2, t 3-3, t 4-4) The default setting is 2 players.
4. Press **START** button to activate game and begin play.
5. Throw darts
The dart indicator display is represented by dart icons. The number of darts displayed indicate the remaining throws for the active player.

When all 3 darts have been thrown, a voice command will indicate "next player" and the score will flash. The darts can now be removed without affecting the electronic scoring. When all darts are removed from the playing surface press the **START** button to go to next player. Voice command will indicate which player is up.

Team Play

In addition to scoring for up to 4 players, this dartboard is capable of keeping score for team play up to a maximum of 4 two-person teams (8 individuals). To enter team play mode, press **PLAYER** button continually until a “t” appears on the display. Each team option is illustrated below:

t 2-2

2 teams, 4 individual players
(1st team-players 1&3, 2nd team-players 2&4)

t 3-3

3 teams, 6 individual players
(1st team-players 1&4, 2nd team-players 2&5, 3rd team-players 3&6)

t 4-4

4 teams, 8 individual players
(1st team-players 1&5, 2nd team-players 2&6, 3rd team-players 3&7, 4th team-players 4&8)

During team play, team members combine their scores to arrive at a team score.

Caring for your Electronic Dartboard

1. **Never use metal tipped darts on this dartboard.** Metal tipped darts will seriously damage the circuitry and electronic operation of this dartboard.
2. **Do not use excessive force when throwing darts.** Throwing darts too hard will cause frequent tip breakage and cause excess wear on the board.
3. **Turn darts clockwise as you pull them from the board.** This makes it easier to remove darts and extends the life of the tips.
4. **Remove the batteries when not in use .** This will prolong the life of your batteries.
5. **Do not spill liquids on the dartboard.** Do not use spray cleaners, or cleaners that contain ammonia or other harsh chemicals as they may cause damage.

Automatic Suspend Mode Feature

The dartboard will automatically suspend if no action occurs within approximately three minutes. This is designed to save power or battery life. A sound effect will play and the display will indicate “SLEEP” (see below). All scores will be stored in memory and play will resume when **any** button is pressed.



Display in Sleep Mode

I-match Feature

This exciting feature allows I-matcher to play against the computer at one of five different levels of skill – only 1 player can compete against the I-match competitor. This adds a level of competition to normally routine practice sessions.

To activate the I-match opponent:

1. Select the Game you wish to play
2. Press **I-MATCH** button
Select I-match opponent skill level by pressing the **I-MATCH** button continually

I-match Levels

Level 1	Professional
Level 2	Advanced
Level 3	Intermediate
Level 4	Novice

3. Press **START** to begin play

When play begins:

The 'human' player throws first. After 3 darts are thrown, go to the board to take darts out and press **START** to change to the next player (I-match). Watch as the I-match opponent's dart scores are registered on the display. After the I-match opponent completes his round, the board will automatically reset for the "human" player. Play continues until one player wins. Good luck!

GAME MENU

30/90 games

G01	301	G46	Round the clock 1 doubles
G02	401	G47	Round the clock 5 doubles
G03	501	G48	Round the clock 10 doubles
G04	601	G49	Round the clock 15 doubles
G05	701	G50	Round the clock 1 triples
G06	801	G51	Round the clock 5 triples
G07	901	G52	Round the clock 10 triples
G08	Cricket	G53	Round the clock 15 triples
G09	No-score cricket	G54	Killer
G10	Scram	G55	Double down
G11	Cut throat cricket	G56	Double down 41
G12	Adv-cricket	G57	All fives 51
G13	Shooter 6 rounds	G58	All fives 61
G14	Shooter 9 rounds	G59	All fives 71
G15	Shooter 12 rounds	G60	All fives 81
G16	Over 3 lives	G61	All fives 91
G17	Over 5 lives	G62	Shanghai 1
G18	Over 7 lives	G63	Shanghai 5
G19	Unders 3 lives	G64	Shanghai 10
G20	Unders 5 lives	G65	Shanghai 15
G21	Unders 7 lives	G66	Golf-9 holes
G22	Count up 300	G67	Golf-18 holes
G23	Count up 400	G68	Football
G24	Count up 500	G69	Bowling
G25	Count up 600	G70	Baseball-6 inning
G26	Count up 700	G71	Baseball-9 inning
G27	Count up 800	G72	Steeplechase
G28	Count up 900	G73	Shove a penny
G29	Count up 999	G74	Nine dart century
G30	Hi Score (3 rounds)	G75	Green vs Red
G31	Hi Score (4 rounds)	G76	Big Six 3 lives
G32	Hi Score (5 rounds)	G77	Big Six 5 lives
G33	Hi Score (6 rounds)	G78	Big Six 7 lives
G34	Hi Score (7 rounds)	G79	Horseshoes 15
G35	Hi Score (8 rounds)	G80	Horseshoes 18
G36	Hi Score (9 rounds)	G81	Horseshoes 21
G37	Hi Score (10 rounds)	G82	Horseshoes 24
G38	Hi Score (11 rounds)	G83	Elimination 3 lives
G39	Hi Score (12 rounds)	G84	Elimination 4 lives
G40	Hi Score (13 rounds)	G85	Elimination 5 lives
G41	Hi Score (14 rounds)	G86	Cat & Mouse
G42	Round the clock 1 single	G87	Gold Hunt 12
G43	Round the clock 5 single	G88	Gold Hunt 15
G44	Round the clock 10 single	G89	Gold Hunt 18
G45	Round the clock 15 single	G90	Gold Hunt 21

Playing Techniques

1. Proper stance: Align your hand, elbow, shoulder, hip, and foot. If throwing with your right hand, turn the right side of your body to face the board. Put your weight on your right foot in the front, lean forward slightly, and balance with your left foot. Reverse this stance for a left-handed throw.
2. Throwing motion: Throw the dart from your elbow out. Keep your body steady and use only your hand, wrist, and forearm. Bring your forearm back slightly and throw the dart with a fluid motion toward the board. Follow through the throw by pointing your index finger at the area at which you are aiming.

Game Rules

1. Each person should have one set of 3 darts (darts not included). Each person throws 3 darts, then removes them before the next person throws.
2. If a dart bounces out it cannot be re-thrown. Dart scores are counted only when the dart sticks in the board.

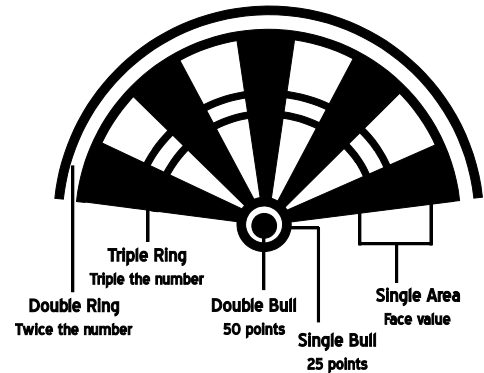

Games

301

This popular tournament and pub game is played by subtracting each dart from the starting number (**301**) until the player reaches exactly 0 (zero). If a player goes past zero it is considered a “*Bus!*” and the score returns to where it was at the start of that round. For example, if a player needs a 32 to finish the game and he/she hits a 20, 8, and 10 (totals 38), the score goes back to 32 for the next round.

401 Starting number 401

501 Starting number 501

601 Starting number 601

701 Starting number 701

801 Starting number 801

901 Starting number 901

CRICKET

Cricket is a strategic game for accomplished players and beginners alike. Players throw for numbers best suited for them and can force opponents to throw for numbers not as suitable for them. The object of Cricket is to “close” all of the appropriate numbers before one’s opponent while racking up the highest number of points.

Only the numbers 15 through 20 and the inner/outer bullseye are used. Each player must hit a number 3 times to “open” that segment for scoring (Refer to Tournament Cricket Scoring section for explanation on how players’ marks are registered). A player is then awarded the number of points of the “open” segment each time he/she throws a dart that lands in that segment, provided their opponent has not closed that segment. Hitting the double ring counts as two hits, and the triple ring counts as 3 hits.

Numbers can be opened or closed in any order. A number is “closed” when the other player(s) hit the open segment 3 times. Once a number has been “closed”, any player for the remainder of the game can no longer score on it.

Winning - The side closing all the numbers first and accumulating the highest point total is the winner. If a player "closes" all numbers first but is behind in points, he/she must continue to score on the "open" numbers. If the player does not make up the point deficit before the opposing player(s) "closes" all the numbers, the opposing side wins. Play continues until all segments are closed - the winner is the player with the highest score.

Cricket Scoring Display

This dartboard utilizes a dedicated scoreboard within the scoring display that keeps track of each player's segment status when playing Cricket. When Cricket is selected, individual characters will be utilized to register marks. There are 3 separate lights within each number (15 through 20 and bullseye). During play, one of the status lights will turn on (black will appear) as a segment is hit. If a double or triple of an active number is hit, 2 or 3 lights will turn on respectively.

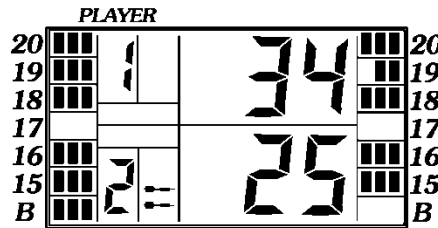

NO-SCORE CRICKET

Same rules as standard Cricket except there is no point scoring. The object of this version is to be the first to simply "close" all the appropriate numbers (15 through 20 and the bullseye).

SCRAM (For 2 players only)

This game is a variation of Cricket. The game consists of two rounds. The players have a different objective in each round. In round 1, player 1 tries to "close" (score 3 hits in each segment - 15 to 20 and bullseye). During this time, player 2 attempts to rack up as many points in the segments that the other player has not yet closed. Once player 1 has closed all segments, round 1 is complete. In round 2, each player's roles are reversed. Now, player 2 tries to close all the segments while player 1 goes for points.

The game is over when round 2 is complete (player 2 closes all segments). The player with the highest point total is the winner.

CUT-THROAT CRICKET

Same basic rules as standard Cricket except once scoring begins, points are added to your opponent(s) total. The object of this game is to end up with the fewest points. This variation of Cricket offers a different psychology to the players. Rather than adding to your own score and helping your own cause as in standard Cricket, Cut-Throat offers the benefit of racking up points for your opponent(s), digging him in a deeper hole. Competitive players will love this variation!

Advanced Cricket

This difficult version of cricket was developed for the advanced player. Players must close out the segments (20,19,18,17,16,15 and bullseye) by using only triples and doubles! In this challenging game, doubles segments count as 1x the number, and triple segments count as 2x the number. The bullseye scoring is the same as in standard cricket. The first player to close out the numbers with the most points is the winner.

Shooter

This challenging game tests the players ability to “group together” darts within a segment during each round of play. The computer will randomly select the segment the players must shoot for at the start of each round – indicated by a flashing number in the display.

Scoring is as follows: Single segment = 1 Point Double segment = 2 Points

Triple segment = 3 Points Single Bullseye= 4 Points.

When the computer selects players to hit double Bullseye, the outer bull scores 2 points and the inner Bull scores 4 points. The player with the most points at the end of the rounds is the winner.

Overs

The object of this game is to simply score higher (“over”) than your own previous three dart total score. Before play begins, players choose the amount of lives to be used by pressing the SELECT button. When a player fails to score “over “ their previous three-dart total, they will lose one life. When a player “equals” the previous three dart total, a life will also be lost. The LED screen on the right will light up once for each life taken away. The last player with a life remaining is the winner.

Unders

This game is the opposite of “Overs” Players must score less (“Under”) than their own previous three-dart total. The game begins with 180 (highest total possible) when the player shoots higher than his or her own previous three-dart total, they will lose a life. Each dart that hits outside the scoring area, including bounce outs will be penalized with 60 points added to your score. The last player with a life remaining is the winner.

COUNT-UP 300

The object of this game is to be the first player to reach the specified point total (300). Point total is specified when the game is selected. Each player attempts to score as many points as possible per round. Doubles and triples count 2 or 3 times the numerical value of each segment. For example a dart that lands in the triple 20 segment is scored as 60 points. The cumulative scores for each player will be displayed in the LCD display as the game progresses. *Additional variations of this game are detailed below. The rules are the same except the point total varies as indicated in the number.*

COUNT-UP 400

COUNT-UP 500

COUNT-UP 600

COUNT-UP 700

COUNT-UP 800

COUNT-UP 900

COUNT-UP 999

High Score - 3 Rounds

The rules for this competitive game are simple - Rack up the most points in three rounds (nine darts) to win. Doubles and triples count as 2x and 3x that segment’s score respectively. ***Additional variations of this game are detailed below. The rules are the same except the number of rounds varies as indicated in the number.***

High Score - 4 Rounds

High Score - 5 Rounds

High Score - 6 Rounds

High Score - 7 Rounds

High Score - 8 Rounds

High Score - 9 Rounds

High Score - 10 Rounds

High Score - 11 Rounds

High Score - 12 Rounds

High Score - 13 Rounds

High Score - 14 Rounds

ROUND-THE-CLOCK– r1 singles

Each player attempts to score in each number from 1 through 20 and bullseye **in order**. Each player throws 3 darts per turn. If a correct number is hit, he/she tries for the next number in sequence. The first player to reach 20 is the winner.

The display will indicate which segment you are shooting for. A player must continue shooting for a segment until it is hit. The display will then indicate the next segment you should shoot for.

There are many difficulty settings available for this game. Each game has the same rules, the differences are detailed as follows:

ROUND-THE-CLOCK 5 - Game starts at segment number 5

ROUND-THE-CLOCK 10 - Game starts at segment number 10

ROUND-THE-CLOCK 15 - Game starts at segment number 15

Since this game does not utilize point scoring, the double and triple rings count as single numbers.

We have added some additional levels of difficulty to this game for those looking for a real challenge!:

ROUND-THE-CLOCK Double- Player must score a **Double** in each segment from 1 through 20 in order.

ROUND-THE-CLOCK Double 5 - Game starts at double segment 5

ROUND-THE-CLOCK Double 10 - Game starts at double segment 10

ROUND-THE-CLOCK Double 15 - Game starts at double segment 15

ROUND-THE-CLOCK Triple - Player must score a **Triple** in each segment from 1 through 20 in order.

ROUND-THE-CLOCK Triple 5 - Game starts at triple segment 5

ROUND-THE-CLOCK Triple 10 - Game starts at triple segment 10

ROUND-THE-CLOCK Triple 15 - Game starts at triple segment 15

KILLER

This game will really show who your friends are. The game can be played with as few as two players, but the excitement and challenge builds with even more players. To start, each player must select his number by throwing a dart at the target area. The LCD display will indicate “SEL” at this point. The number each player gets is his assigned number throughout the game. No two players can have the same number. Once each player has a number, the action starts.

Your first objective is to establish yourself as a “Killer” by hitting the double segment of your number. Once your double is hit, you are a “Killer” for the rest of the game. Now, your objective is to “kill” your opponents by hitting their segment number until all their “lives” are lost. The last player to remain with lives is declared the winner. It is not uncommon for players to “team up” and go after the better player to knock him out of the game.

DOUBLE DOWN

Each player starts the game with 40 points. The object is to score as many hits in the active segment of the current round. The first round, the player must throw for the 15 segment. If no 15's are hit, his score is cut in half. If some 15's are hit, each 15 (doubles and triples count) is added to the starting total. The next round players throw for the 16 segment and hits are added to the new cumulative point total. Again, if no hits are registered, the point total is cut in half.

Each player throws for the numbers as indicated in the chart below in order (the LCD screen will indicate the active segment in which to throw). The player who completes the game with the most points is the winner.

	15	16	D	17	18	T	19	20	B	TOTAL
Player 1										
Player 2			↑			↑				

Any Double

Any Triple

DOUBLE DOWN 41

This game follows similar rules as standard Double Down as described above with two exceptions. First, instead of going from 15 through 20 and bullseye, the sequence is reversed which will be indicated on the LCD display. Second, an additional round is included toward the end in which players must attempt to score three hits that add up to 41 points (20, 20, 1; 19, 19, 3; D10, D10, 1; etc.). This "41" round adds an extra level of difficulty to the game. Remember, a player's score is cut in half if not successful, so the "41" round presents quite a challenge!

	20	19	D	18	17	T	16	15	41	B	TOTAL
Player 1											
Player 2											

Any Double

Any Triple

'41' Round

ALL FIVES - 51

The entire board is in-play for this game (all segments are active). With each round (of 3 darts) each player has to score a total which is divisible by 5. Every "five" counts as one point. For example 10, 10, 5 = 25. Since 25 is divisible by 5 fives, this player scores 5 points (5 x 5 = 25).

If a player throws 3 darts that are not divisible by 5, no points are given. Also, the last dart of each round must land in a segment. If a player throws the third dart and it lands in the catch ring area (or misses the board completely), he earns no points even if the first two darts are divisible by 5. This prevents a player from "tanking" the third throw if his first two are good. The first player to total fifty-one (51) "fives" is the winner. The LCD screen will keep track of the point totals. **Additional variations of this game are detailed below. The rules are the same except the total needed to win varies as indicated in the number following the game.**

ALL FIVES - 61

ALL FIVES - 71

ALL FIVES - 81

ALL FIVES - 91

SHANGHAI - 1

Each player must progress around the board from 1 through 20 in order. Players start at number 1 and throw 3 darts. The object is to score the most points possible in each round of 3 darts. Doubles and triples count toward your score. The player with the highest score after completing all twenty segments is the winner. **Additional variations of this game are detailed below. The rules are the same except the starting segment varies as indicated in the number following the game.**

SHANGHAI 5 - Game starts at segment 5

SHANGHAI 10 - Game starts at segment 10

SHANGHAI 15 - Game starts at segment 15

GOLF – 9 Holes

This is a dartboard simulation of the game golf (but you don't need clubs to play). The object is to complete a round of 9 through 18 "holes" with the lowest score possible. The Championship "course" consists of all par 3 holes making par 27 for a nine hole round or 54 for a round of 18.

The segments 1 through 18 are used with each number representing a "hole." You must score 3 hits in each hole to move to the next hole. Obviously, double and triples affect your score as they allow you to finish a hole with fewer strokes. For example, throwing a triple on the first shot of a hole it is counted as an "eagle" and that player gets to complete that hole with 1 "stroke."

Note: The active player continues to throw darts until he "holes out" (scores 3 hits on the current hole). The voice announcer will indicate the player that is up - listen carefully to avoid shooting out of sequence. By the way, there are no "gimmes" in this game! **Additional variations of this game are detailed below.**

The rules are the same except the number of holes needed to play.

GOLF – 18 Holes – Same as above except play lasts 18 holes (rounds)

FOOTBALL

Strap your helmet on for this game! The first thing necessary is to select each player's "playing field." Each player can do this by throwing a dart or by manually pressing a segment on the board. This is entirely up to you, but whichever segment is selected it becomes your starting point which carries through the bullseye and directly across to the other side of the bullseye.

For example, if you select the 20 segment, you start on the double 20 (outer ring) and continue all the way through to the double 3. The "field" is made up of 11 individual segments and must be hit in order. So, keeping with the example above, you must throw darts in the following segments in this order:

Double 20 ... Outer Single 20 ... Triple 20 ... Inner Single 20 ...

Outer Bullseye ... Inner Bullseye ... Outer Bullseye ... Inner Single 3 ...

Triple 3 ... Outer Single 3 ... and finally a Double 3.

The First player to "score" is the winner. The display will keep track of your progress and indicate the segment you need to throw for next.



BOWLING

This dartboard adaptation of bowling is a real challenge! It is a difficult game in that you must be very accurate to rack up a decent score. Player one starts the game. You must select your "alley" by either throwing dart or manually pressing segment of choice. Once alley is selected, you have 2 remaining darts to throw in which to score points or "pins." Each specific segment in your "alley" is worth a given pin total:

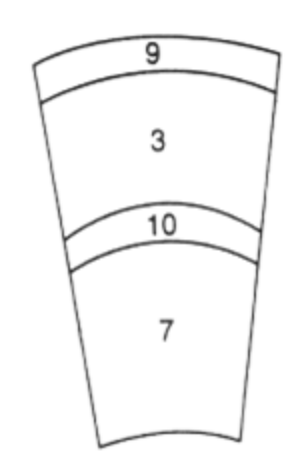

<u>Segment</u>	<u>Score</u>
Double	9 pins
Outer Single	3 pins
Triple	10 pins
Inner Single	7 pins

There are several rules for this game as follows:

1. A perfect game score would be 200 in this version of bowling
2. You cannot hit the same singles segment twice within the same "frame" (round). The second hit will count as zero points. **Hint:** Try to hit each single to reach 10 points in the frame.
3. You can score 20 points per "frame" by hitting the triple segment twice.
4. Hitting the double segment with your second dart will only count as 10 points if you scored a double on your first throw. Otherwise you will score a total of 9 points by throwing a double with your second dart.

BASEBALL – 6 Innings

This dartboard version of baseball takes a great deal of skill. As in the real game, a complete game consists of 9 innings. Each player throws 3 darts per "inning." The field is laid out as shown in the diagram.

<u>Segment</u>	<u>Result</u>
Singles segments	"Single" - one base
Doubles segment	"Double" - two bases
Triples segment	"Triple" - Three bases
Bullseye	"Home Run" (<i>can only be attempted on third dart of each round</i>)

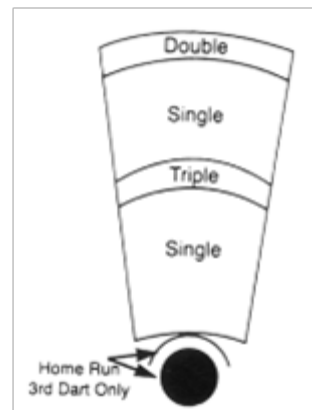

The object of the game is to score as many runs as possible each inning. The player with the most runs at the end of the game is the winner.

BASEBALL – 9 Innings – Same as above except 9 innings (rounds).

STEEPLECHASE

The object of this game is to be the first player to finish the “race” by being the first to complete the “track.” The track starts at the 20 segment and runs clockwise around the board to the 5 segment and ends with a bullseye. Sounds easy right? What has not yet been specified is that you must hit the inner single segment of each number to get through the course. This is the area between the bullseye and the triples ring. And, as with a real steeplechase, there are obstacles throughout the course to hurdle. The four hurdles are found at the following places:

- 1st fence Triple 13
- 2nd fence Triple 17
- 3rd fence Triple 8
- 4th fence Triple 5

The first player to complete the course and hit the bullseye wins the race.

SHOVE A PENNY

Only the numbers 15 through 20 and the bullseye are used. Singles are worth 1 point, doubles are worth 2, and triples are worth 3 points. Each player must throw for the numbers in order with the objective of scoring 3 points in each segment to move on to the next. If a player scores more than 3 points in any one number, the excess points are given to the next player. The first player to score 3 points in all segments (15 - 20 and bull) is the winner.

NINE-DART CENTURY

The object of this game is to attempt to score 100 points, or come as close as possible, after 3 rounds (9 darts). Doubles and triples count as 2x and 3x their value respectively. Going over 100 points is considered a “bust” and causes you to lose unless all players go over. In that case, the player closest to 100 wins (player that scored the lowest amount over 100).

GREEN VS. RED

(2 players only)

This game is a race around the board, where skill at hitting doubles and triples pays off with victory. Player 1 is “green” and player 2 is “red.” Player 1 shoots for only doubles and triples that are green and works around the board clockwise. Player 2 starts at 20 and works around the board counter-clockwise, shooting for red segments (the temporary score display will indicate which segment to throw for). Note: a maximum of one double and one triple of the same number can be scored in a single round.

What’s more, hitting the wrong number (of your opponent’s color) **subtracts** that amount from your score - so be careful.

The player with the most points after completion of the game is the winner.

Big Six

This game allows players to challenge their opponents to hit the targets of their choice. However, players must *earn* the chance of picking the next target for their opponent by making a hit on the current target first.

Single 6 is the first target to hit when the game begins. Before the game starts, players must agree on how many lives will be used by pressing **SELECT** button. Within the three throws, player 1 must hit a 6 to “save” their life. After the current target is hit, the next dart thrown will determine the opponents target. If player 1 fails to hit the current target within 3 darts, they will lose a life and a chance to determine the next target for player 2. Player 2 will shoot for the single 6 that player 1 missed. Singles, doubles and triples are all separate targets for this game.

The object of the game is to force your opponent into losing lives by selecting tough targets for your opponent to hit such as “Double Bullseye” or “triple 20” The last player with a life left is the winner.

Horseshoes

This 2 -player game uses only the 20 and 3 segments to represent the two horseshoe pits. Player 1 will shoot at the 20 segment and Player 2 will shoot at the 3 segment. Scoring is cumulated per round. First player to score 15 points is the winner.

Scoring is as follows:

TRIPLE RING = Ringer 3 points
DOUBLE RING= Leaner 2 points
INNER SEGMENT (Small)= 1 point

Scores will only count for the player or team with the most points in that round. For example, if player 1 scores 3 points and player 2 scores 1 point, only player 1 will awarded 3 points for that round. Rounds continue until 15 points are scored.

Adjustable Difficulty Settings for Horseshoes include games from 15- 25 points. Press the **SELECT** button before starting the game for these variations.

Elimination

The object of the game is to “Eliminate” your opponents. The rules are very simple. Each player must score higher total points with 3 darts than the opponent before them. Each player starts with 3 lives. If the player fails to score higher total points than the previous opponents score, they lose one life. Tie scores will also result in a lost life. The winner is the last player with lives remaining. Press the SELECT button before starting to play with 4 or 5 lives per player.

Cat & Mouse

This is a very challenging 2-player game that is best suited for players of advanced skill. One player will play the role of the cat and the other will be the mouse. The object of the game is for the mouse to get back to his hole before being caught by the cat. The mouse starts first from the “20” segment and proceeds counter-clockwise around the dartboard by hitting first the double segment and then the single of each segment. The cat starts back at the “18” segment and proceeds counter clockwise around the dartboard to catch the mouse by hitting doubles only of each segment. If the mouse makes it all the way around the board back to the double 20, the mouse wins the game. If the cat hits the double segment that the mouse is on, the cat has caught the mouse and has won the game.

GOLD HUNTING

The object of this game is to find “gold.” You collect gold for each 50 points. Gold is only collected only if your score is exactly 50 or a multiple of 50 (100, 150, etc.) at any point during a round. However, since “gold” can make a person greedy, not only do you collect gold for every multiple of 50, you also steal 1 gold from all other players. Therefore, as you collect a gold, you take 1 gold from all other players who have gold.

This is a real back-and-forth game, but the player who reaches to selected total gold required first is the winner.

Important Notes

Stuck Segment

Occasionally, a dart will cause a segment to become wedged within the segment separator web. If this happens, all play will be suspended and the scoring display will indicate the segment number that is stuck.

To free the segment, simply remove the dart or broken tip from the segment. If the problem is still not solved, try wiggling the segment until it is loose. The game will then resume where it left off.

Broken Tips

From time to time a tip will break off and become stuck in the segment. Try to remove it with a pair of pliers or tweezers by grasping the exposed end and pulling it out of the segment. If this is not possible, you can attempt to push the tip through to the back of the segment. Use a nail that is smaller than the hole and gently push the tip until it falls through the other side. Be careful not to push too far and damage the circuitry behind the segment.

Don't be alarmed if tips break. This is a normal occurrence when playing soft tip darts. We include a pack of replacement tips that should keep you supplied for quite some time. When replacing tips, make sure you use the same type of tips that come with this dartboard.

Cleaning your Electronic Dartboard

Your TRIUMPH SPORTS USA™ electronic dartboard will provide many hours of competition if cared for properly. Regular dusting of the cabinet is recommended using a dry cloth. The use of abrasive cleaners or cleaners that contain ammonia may cause damage and should not be used. Avoid spilling liquid onto the target area since it can result in permanent damage and is not covered by the warranty.