

# Technical Specifications

## Uniframe® Convertible Bench

August 2015

### 15-Year Warranty

All benches described herein shall carry a 15-year warranty for frames, tops/backs and benches.

### Dimensions

	29" H	27"H
Folded height shall be	33 1/4"	31 1/4"
Folded depth shall be	22"	22"
Bench height shall be	17"	15"
Bench length shall be	96"	96"
Top height shall be	29"	27"
Depth when unit is in use (bench folded down and top either up or down) shall be	29 1/2"	27 1/2"



### Tops/Backs and Benches

Tops/backs and benches shall be of solid core nominal 3/4" thick warp-resistant construction. Center core shall be of 45 PCF density particle board. A .030 high-pressure laminate face shall be used for the top surface with a .030 high-pressure laminate backer for the bottom surface. The frame shall be secured to the top and bench with deep thread screws, expansion rivets are not to be used. Corners have a 2 1/2" radius. Tops shall measure 14 3/4" wide by 3/4" thick by the length of the bench. Benches shall measure 12 1/4" wide by 3/4" thick by the length of the bench.

### Edges

Table top edges shall be finished in one of the following:

#### Bullnose Edge

Edges shall be banded with an abrasion-resistant black vinyl bullnose molding. The barbed "T" design shall be inserted into a routed groove in the solid particleboard top and held in place with nails driven from the underside, spaced 8-10" apart.

#### 73P Edge

Edges shall be banded with a 2mm flat polypropylene edge banding that is chemically bonded to the table core.

### Frames

Frames shall be fabricated using a welded unitized construction, integrating all structural steel members and the ganging mechanism into a self-supporting unit. The top/back support apron shall be 18-gauge bent and welded steel. Leg supports shall be 14-gauge square steel tubing. The main pivot folding action shall be heavy-duty 14-gauge steel tubing coupled with thick 11-gauge saddles. The lower leg base shall be welded to the leg assembly.

### Frame Finish

Powder-coat frame finish shall be non-chipping electrostatically applied and baked. Finish is black only, with optional chrome legs.

### Ganging Mechanism

Steel ganging mechanism shall be provided on all tables as standard, allowing two tables to be locked together into a common unit. Mechanism shall be located on each end, on top of the foot tube for easy access.

### Bench Support Foot Caps

Bench support foot caps shall be black poly.

### Casters

Large 4" diameter heavy-duty hard rubber swivel casters, two locking and two non-locking, provide easy and safe maneuverability.

### General

Convertible benches shall ship knocked down in two boxes for customer assembly (unassembled).

**Uniframe® Convertible Bench**  
 Technical Specifications

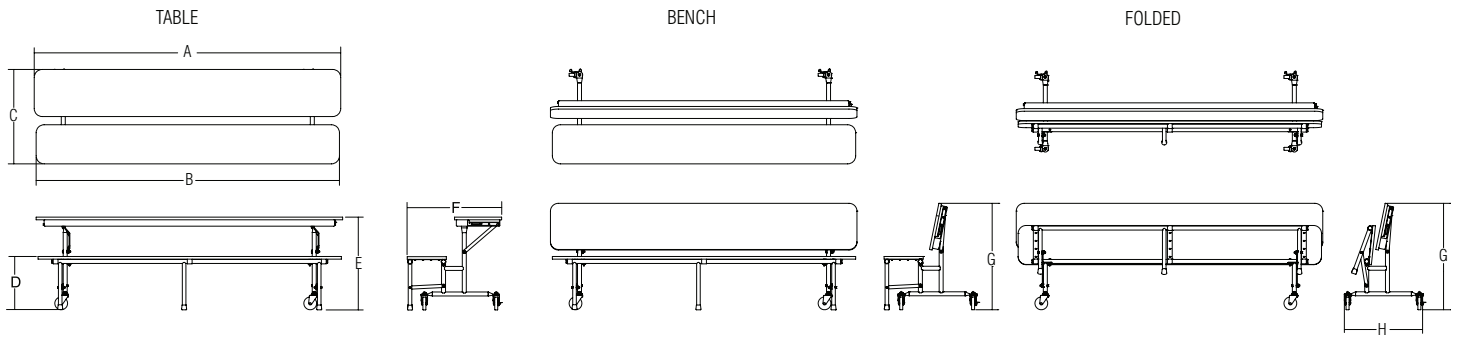

MODEL #	A	B	C	D	E
UCB8	96.0"	95.0"	29.5"	16.5"	29.0"

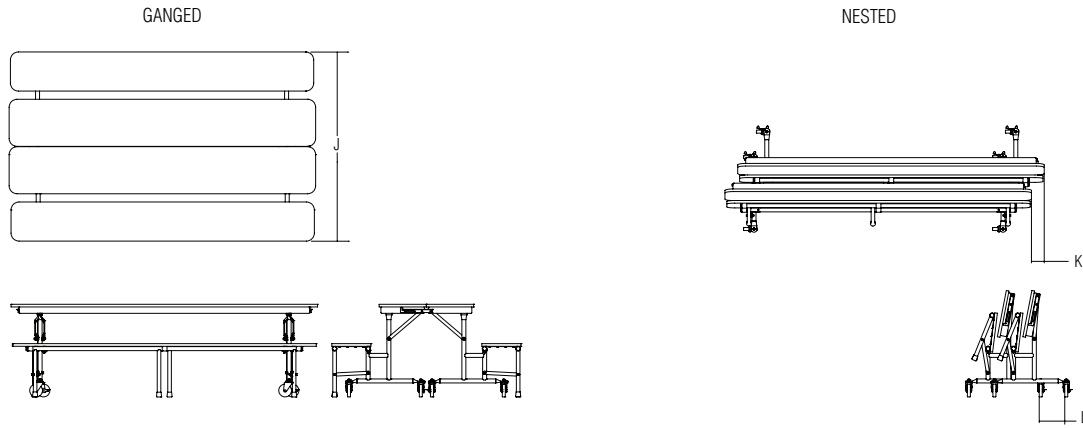

MODEL #	G	H	J	K	L
UCB8	33.25"	24.5"	90.25"	4.0"	8.0"