

CURIO CABINET BLACK

ASSEMBLY INSTRUCTION



ASSEMBLY INSTRUCTION

ASSEMBLY TIPS:







- 1.Remove hardware from box and sort by size.
- 2.Please check to see that all hardware and parts are present prior to start of assembly.
- 3.Please follow attached instructions in the same sequence as numbered to assure fast & easy assembly.









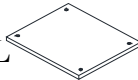
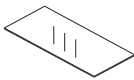







Warning!!

- 1.Don't attempt to repair or modify parts that are broken or defective.Please contact the store immediately.
- 2.This product is for home use only and not intended for commercial establishment.

PARTS IDENTIFICATION

<p>A</p> <p>DOOR GLASS</p>  <p>1PC</p>	<p>D</p>   <p>PLASTIC BAR</p> <p>2PCS</p>
<p>B</p> <p>SIDE GLASS</p>  <p>2PCS</p>	<p>E</p>  <p>SHELF SUPPORT</p> <p>4PCS</p>
<p>C</p> <p>BACK GLASS</p>  <p>1PC</p>	<p>F</p>  <p>TOP WOOD PANEL</p> <p>1PC</p> <p>G</p>  <p>BOTTOM WOOD PANEL</p> <p>1PC</p> <p>H</p>  <p>SHELF GLASS</p> <p>4PCS</p>

HARDWARE PACKAGE

Z	DESCRIPTION	FIGURE	Q'TY
1	LEG		4PCS
2	ALLEN BOLT-LARGE		8PCS
3	WASHER		8PCS
4	HINGE		4PCS
5	HINGE INSERT		4PCS
6	METAL WITH ADHESIVE		4PCS
7	SMALL BOLT		8PCS
8	PLASTIC MAGNET		4PCS
9	HANDLE		2PCS
10	METAL CONTACT		2PCS
11	ADHESIVE		4PCS
12	SCREW		4PCS
13	ALLEN KEY		1PC
14	SUCTION CUP		16PCS
15	BOLT		16PCS

STEP 1

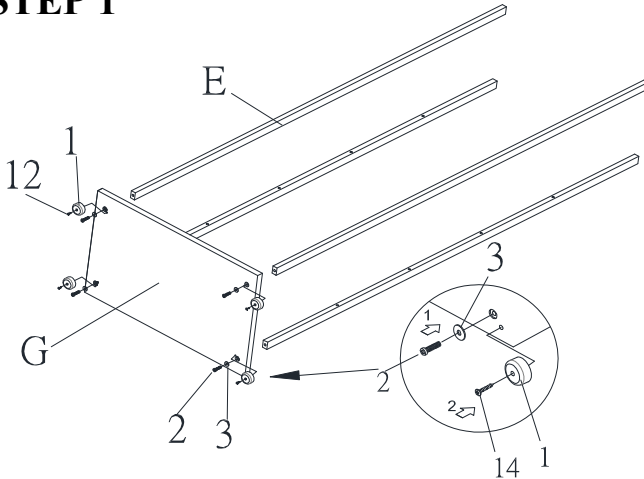

SETP 1 :

Assemble the Bottom Wood Panel (G) and Inner Shelf Support (E) with Washer (3) and Allen Bolt-Large (2) as illustrated. Tighten bolt with Allen Key (13). Assemble Legs (1) onto the Bottom Wood Panel (G) with Screws (12) as illustrated. Tighten screw with Allen Key (13).

STEP 2

Step 2 :
Insert Back Glass (C) into the Plastic Bars (D) into the side that is less deep. Reference the image closely for this step.

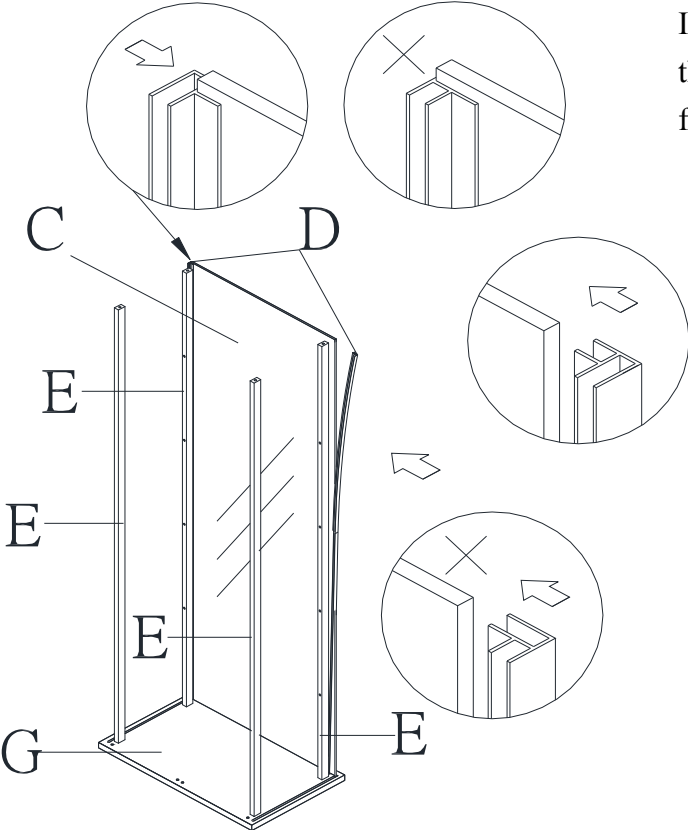

STEP 3

Step 3 :
Insert each Side Glass (B) downward and into the Plastic Bar (D). Screw the Top Wood Panel (F) onto the Frame by inserting Allen Bolts-Large (2) through Washers (3) and onto the Panel. Tighten with Allen Key (13).

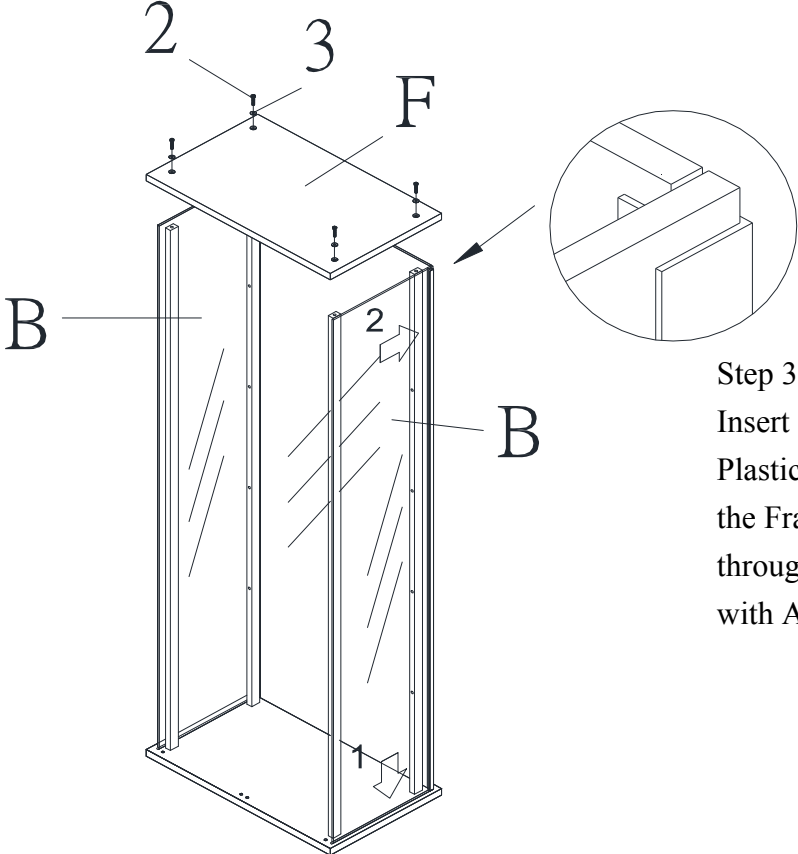

STEP 4

14

15

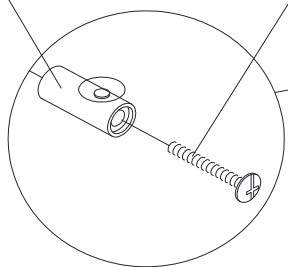

14

15

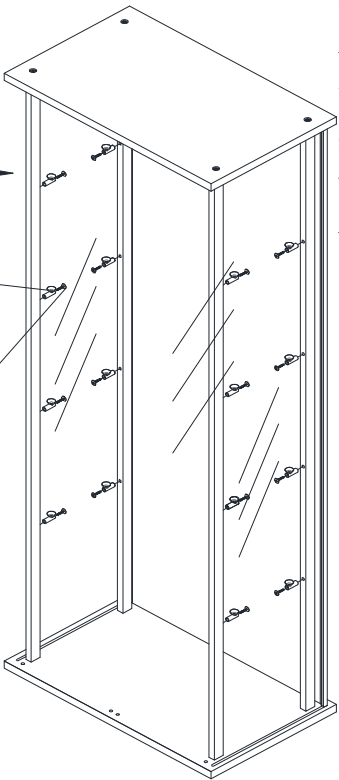

Step 4 :

Assemble the suction cups (14) on shelf support (E) using middle sized bolt (15) and turn enough to secure in place, but not all the way.

We will come back to this step to tighten the bolts when the curio assembly is almost completed.

STEP 5

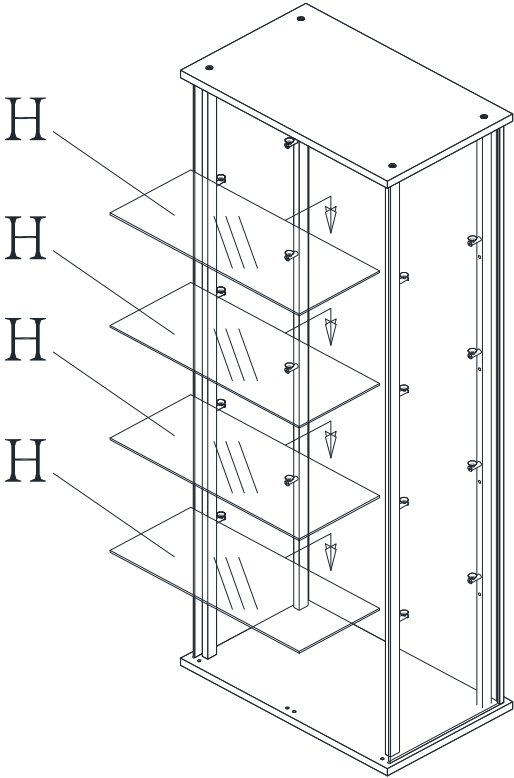

Step 5 :

Place shelf glass (H) on the shelf support (E) .

STEP 6

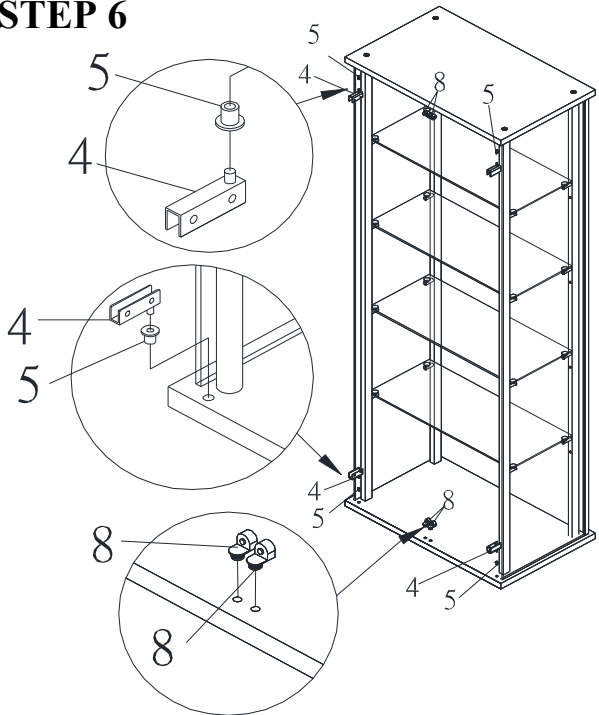

Step 6 :

Insert Hinge Inserts (5) and Hinges (4) into the top and bottom Panels (F&G) of the frame as illustrated. Insert Plastic Magnets (8) into the top and bottom Panels (F&G) of the frame as illustrated.

STEP 7

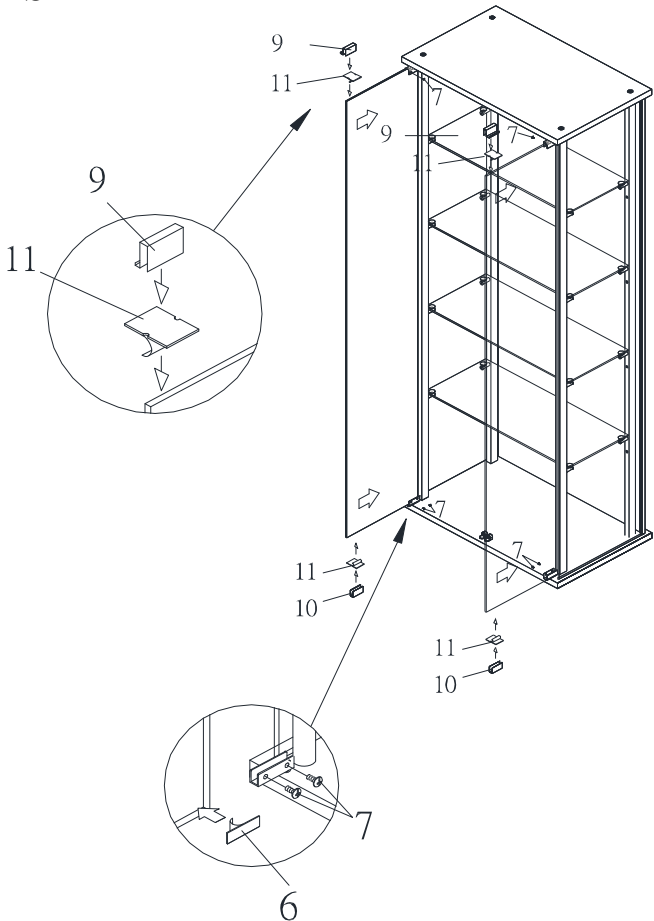

Step 7 :

Place Adhesives (11) on top and bottom corners of the Door Glass (A) as illustrated in diagram. Place Handle (9) and Metal Contact (10) on Door Glass (A) over the adhesives. Place Metal With Adhesive (6) on the bottom and top corners of the glass door, then slide the glass door into the Hinges(4). Lock the door into place with Small Bolts (7).

FINISH

