

ASSEMBLY INSTRUCTIONS

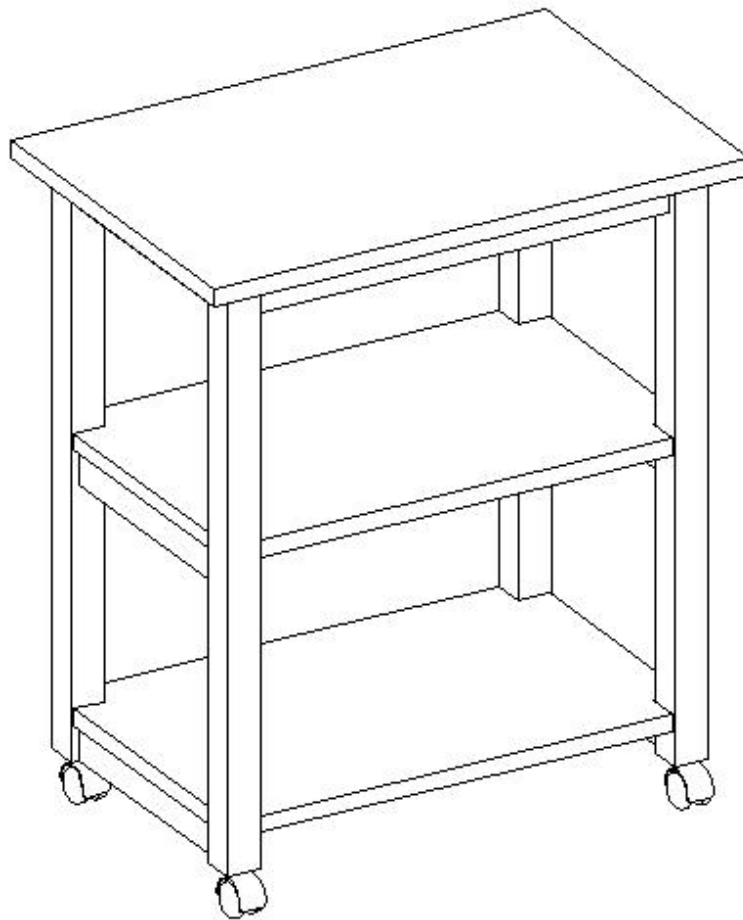

Description : MICROWAVE CART
Item No. : 185

BEFORE ASSEMBLY

Thank you for purchasing this quality product. This product has been designed for easy assembly and constructed for durability. All parts were checked prior to packaging to insure quality. Prior to beginning assembly, however, make sure all parts and hardware are included and free of obvious defect. If a part is missing or defective, please contact the store where purchased. If hardware is missing, or you need help with assembly, please call toll free 888-944-8396.

IMPORTANT NOTE:

- Place all wooden parts on a clean and smooth surface such as a rug or carpet to avoid the parts from being scratched.
- Remove all wrapping material, including staples & packing straps before you start to assemble.
- DO NOT tighten all screws and bolts until completely assembled.
- Keep all hardware parts out of reach of children.

ASSEMBLY TOOLS REQUIRED

NOT INCLUDED

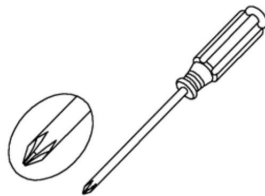





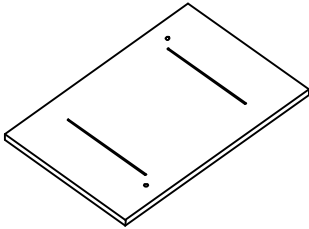
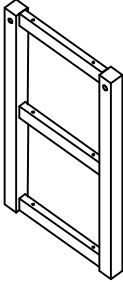
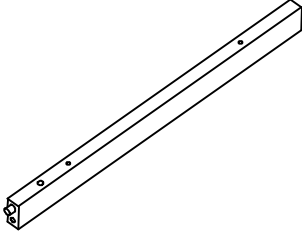
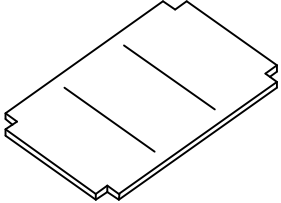

PART LIST

When unpacking, please be careful not to discard any parts with the packaging. Before continuing, please make sure you have the following parts:

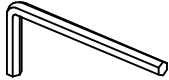
A	Top	01		C	Side frame	02	
B	Apron	02		D	Shelf	02	

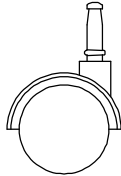
HARDWARE LIST

When unpacking, please be careful not to discard any parts with the packaging. Before continuing, please make sure you have all of the following hardware:

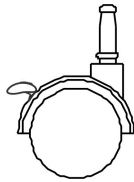
NO	Description	Qty	Sketch	NO	Description	Qty	Sketch
1	Bolt (M6x60mm)	4		5	Allen key (4x80mm)	1	
2	Barrel nut (Φ6x13mm)	4		6	Castor (Φ40mm)	2	
3	Wood button (Φ14.5mm)	4		7	Castor insert cap	4	
4	Screw (M4x30mm)	16		8	Lock castor (Φ40mm)	2	

ITEM NO : 185
REVISED FEB 02, 2013

Printed in Vietnam

STEP 1

Attach aprons (B) to side frames (C) with bolts (1) and nuts (2). Tighten with Allen key (5).

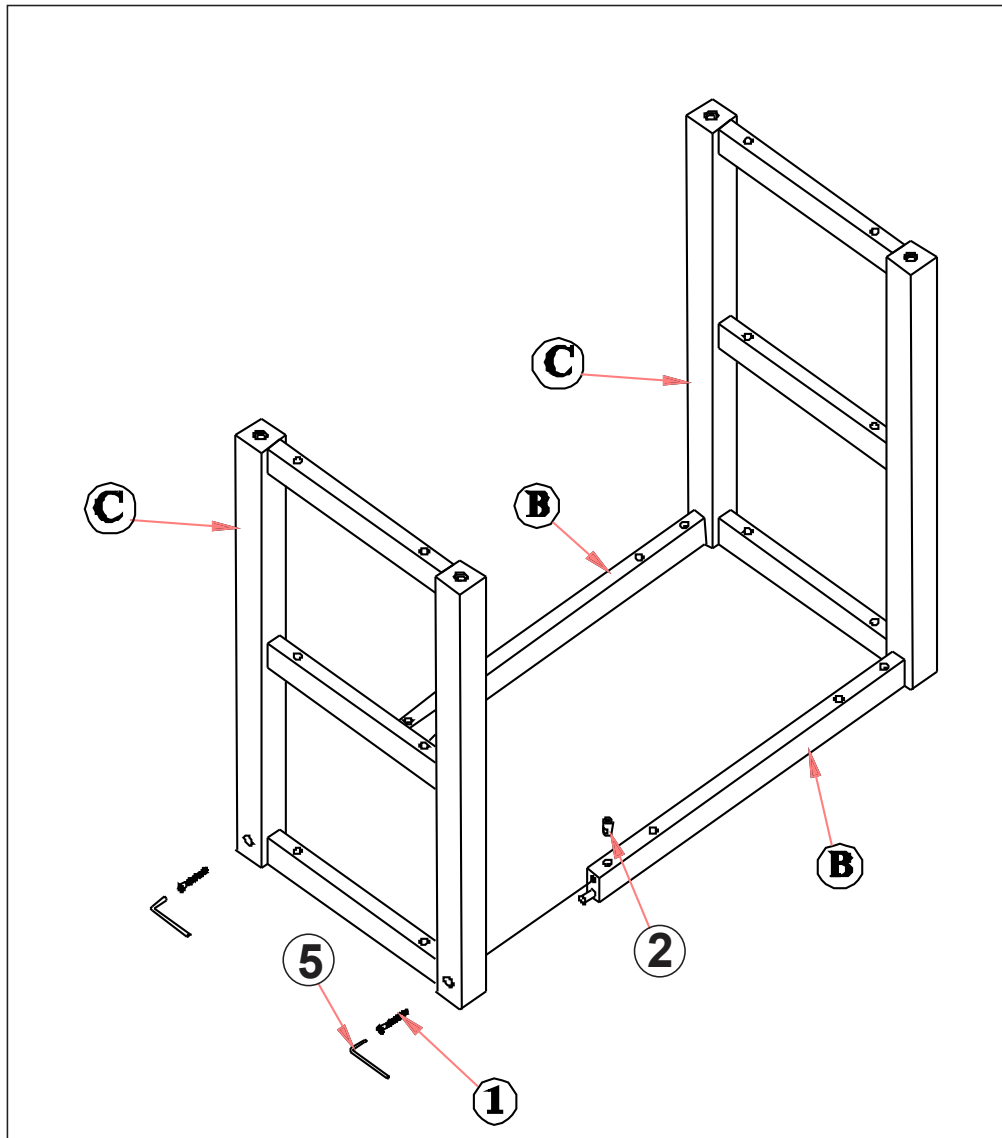

STEP 2

Attach shelves (D) to the side frames (C) with screws (4). Tighten with a screwdriver.

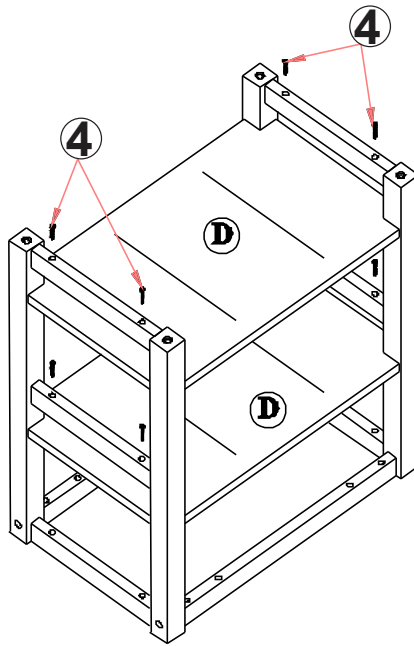

STEP 3

Attach the base (from step 2) to top (A) with screws (4). Tighten with a screwdriver.

Attach castors (6) and lock castors (8) with castors insert caps (7) to leg bottom of side frames (C) as shown below.

Insert wood buttons (3) over bolts to cover them.

