



© 2012 KidKraft, LP

# Fancy Nancy™ Table & Chair Set











## Assembly Instructions

Item #25001

Please retain this information for future reference

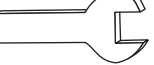
To order replacement parts, please visit [www.kidkraft.com](http://www.kidkraft.com)

### HARDWARE

- A. Threaded Rod x 8 pcs  

- B. Bolt Anchor x 4 pcs  

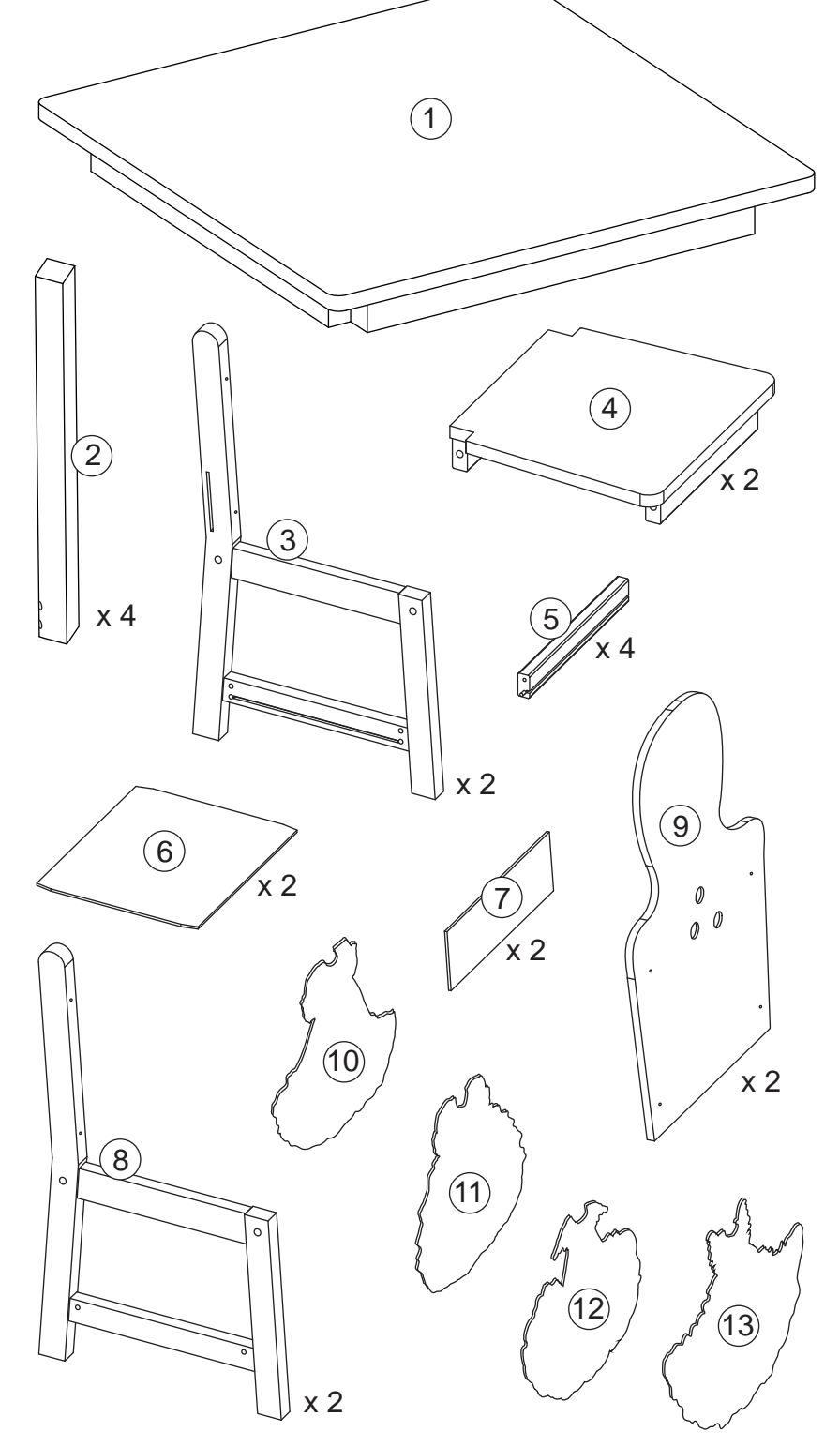
- C. Flat Washer x 8 pcs  

- D. Lock Nut x 8 pcs  

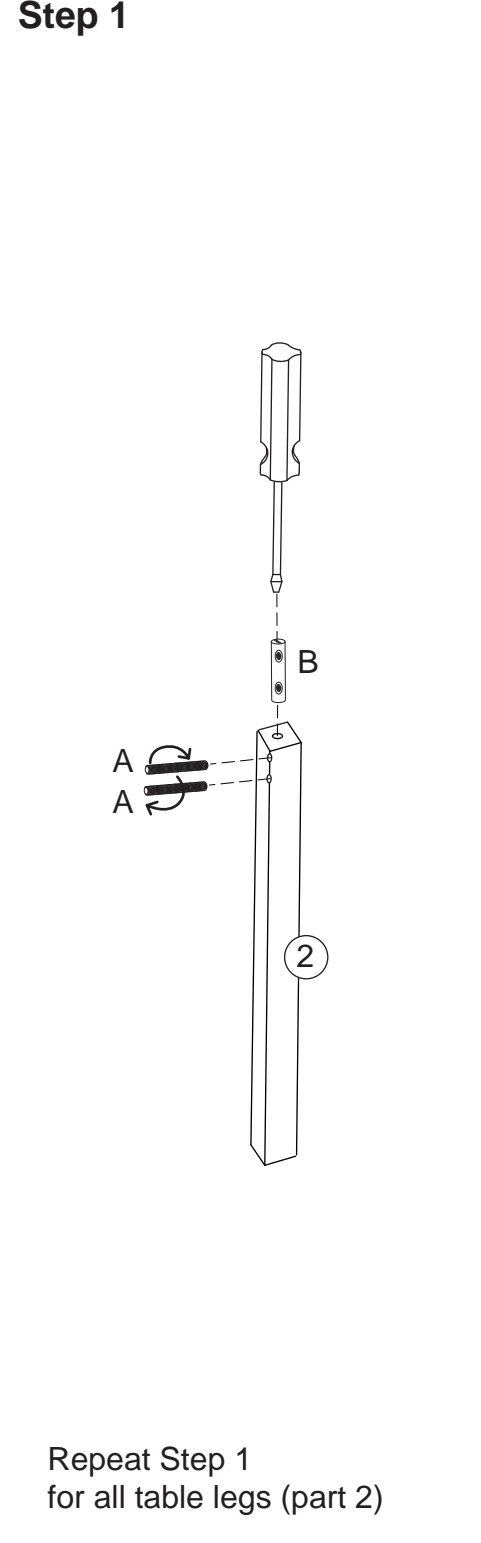
- E. Screw x 16 pcs  
1 3/8 in, 35 mm  

- F. Cross Dowel Bolt x 8 pcs  
2 1/16 in, 52 mm  

- G. Cross Dowel Nut x 8 pcs  

- Wrench x 1 pc  

- Allen Wrench x 1 pc  

- The following tools (not included) are required for assembly :
-  Flathead screwdriver
-  Phillips® Screwdriver

### PARTS LIST



### Table Assembly Step 1



### Step 2

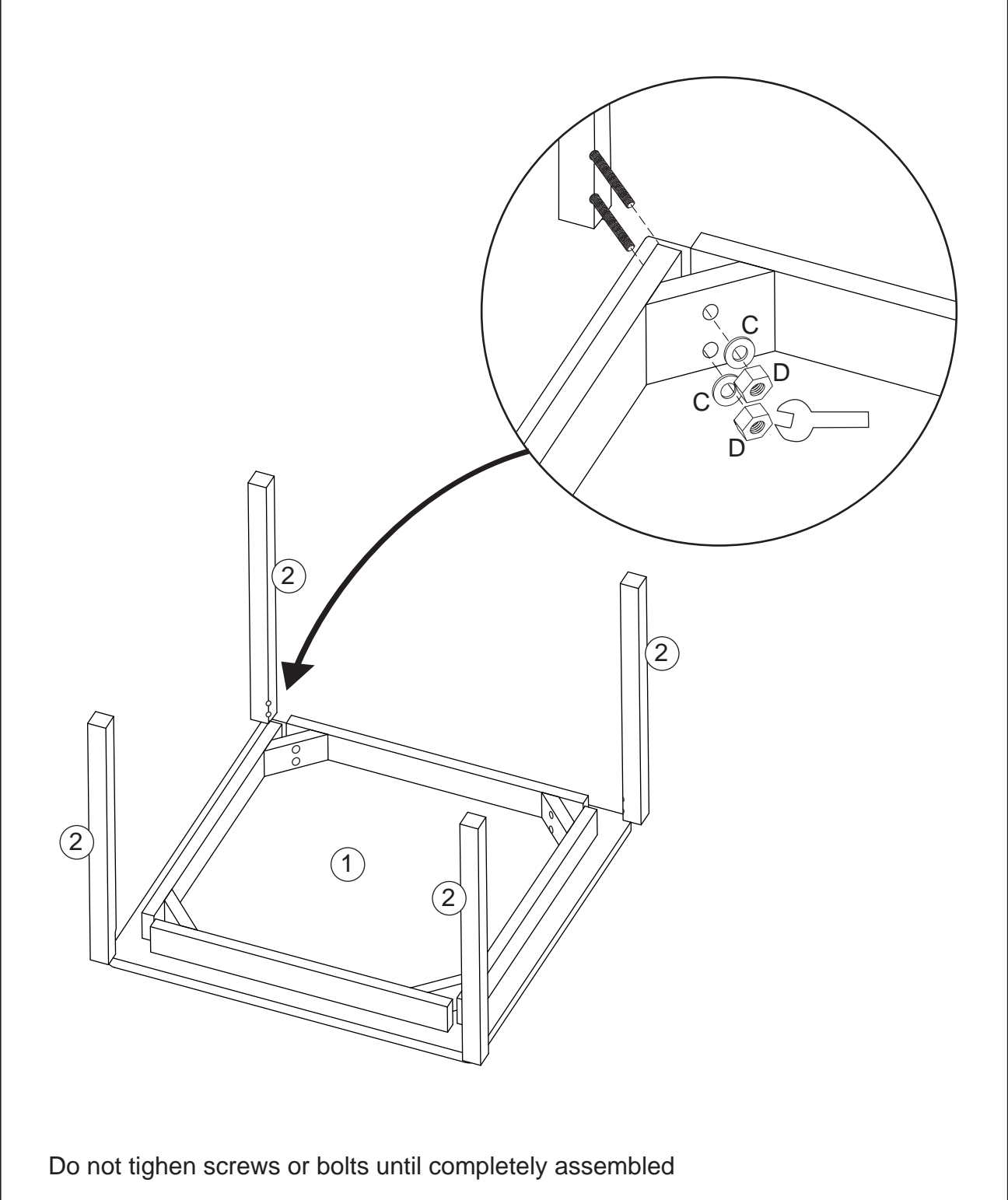

**⚠ WARNING:**  
ADULT ASSEMBLY REQUIRED. Product includes small parts with potentially hazardous sharp points and sharp edges in the unassembled state. Keep unassembled parts away from children.

**USE AND MAINTENANCE:**  
-Use on level surfaces only  
-Please check assembly at regular intervals, and frequently tighten hardware if necessary. If maintenance is not carried out, the product could cease to function properly.

**⚠ WARNING:**  
CHOKING HAZARD. Small parts and sharp points, not suitable for children under 3 years.

**Customer Service**  
**1-800-933-0771**  
**[www.kidkraft.com](http://www.kidkraft.com)**



© 2012 KidKraft, LP

# Fancy Nancy™ Table & Chair Set Assembly Instructions

Item #25001

Please retain this information for future reference

To order replacement parts, please visit [www.kidkraft.com](http://www.kidkraft.com)

## Chair Assembly Step 3

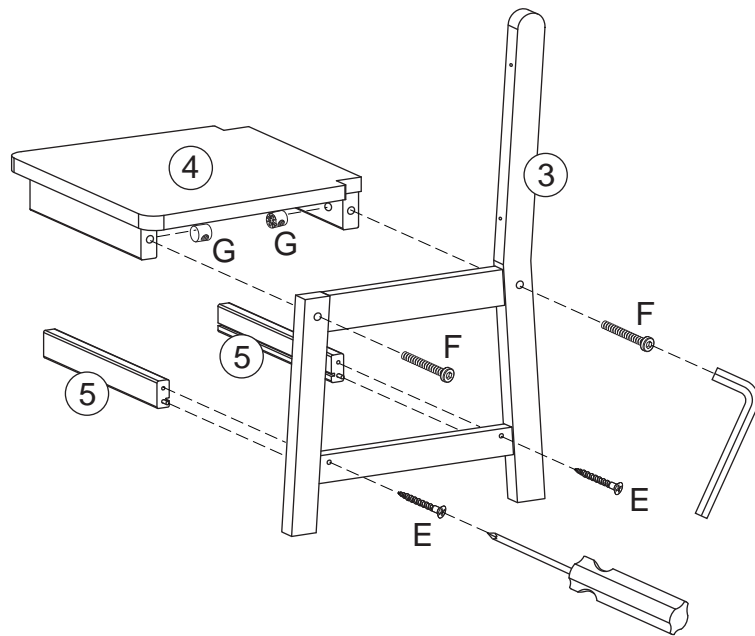

## Step 4

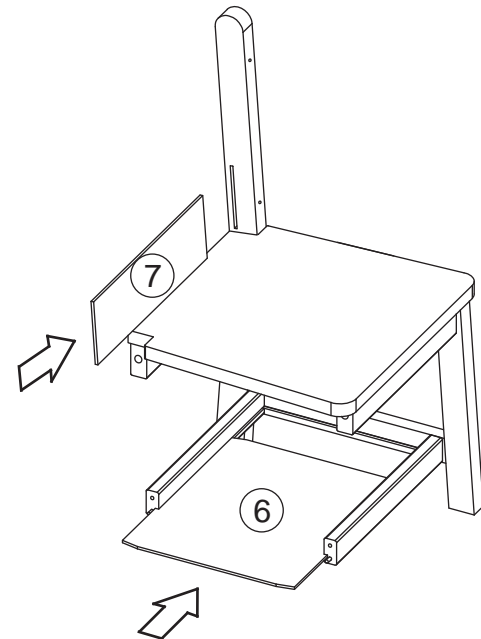

## Step 5

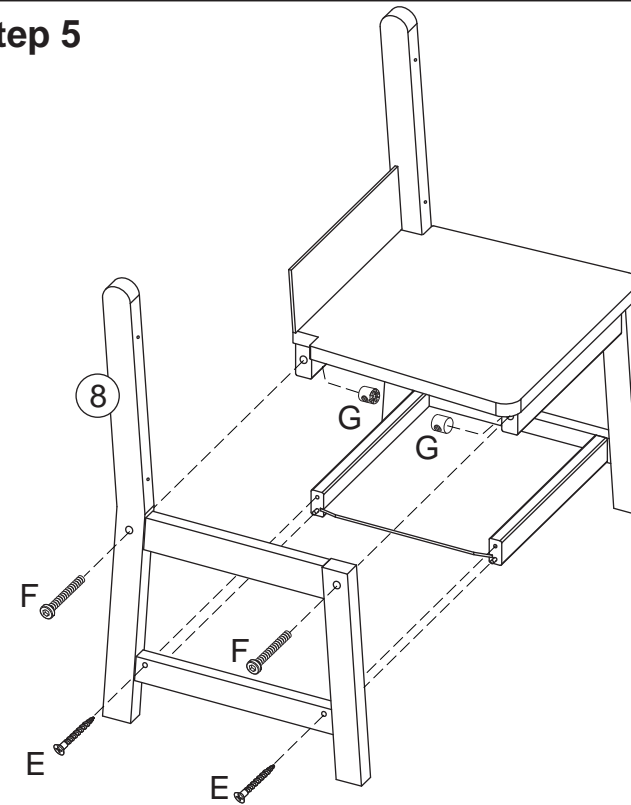

## Step 6

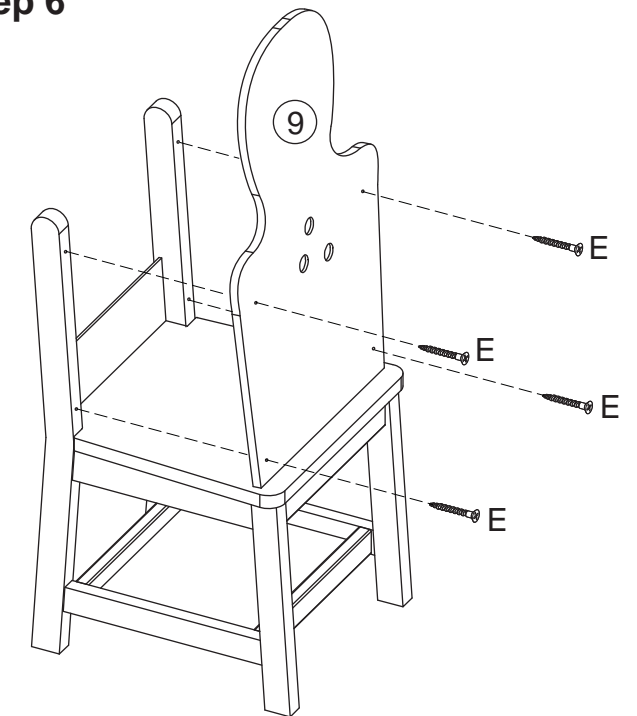

Repeat step 3-6 for the second chair

## Complete

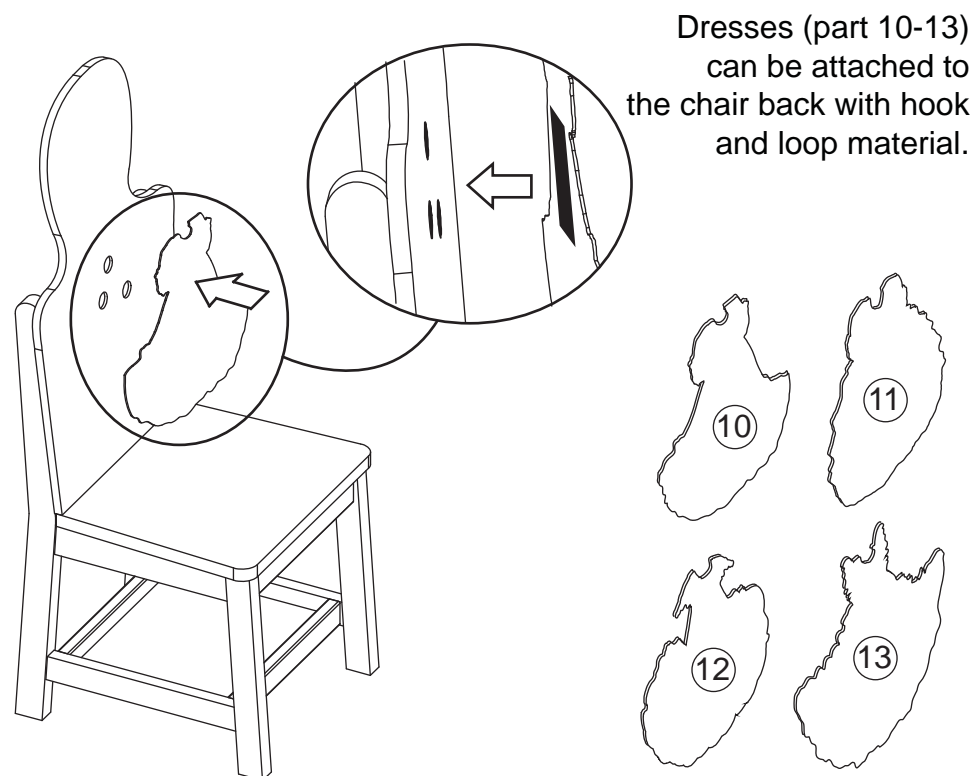
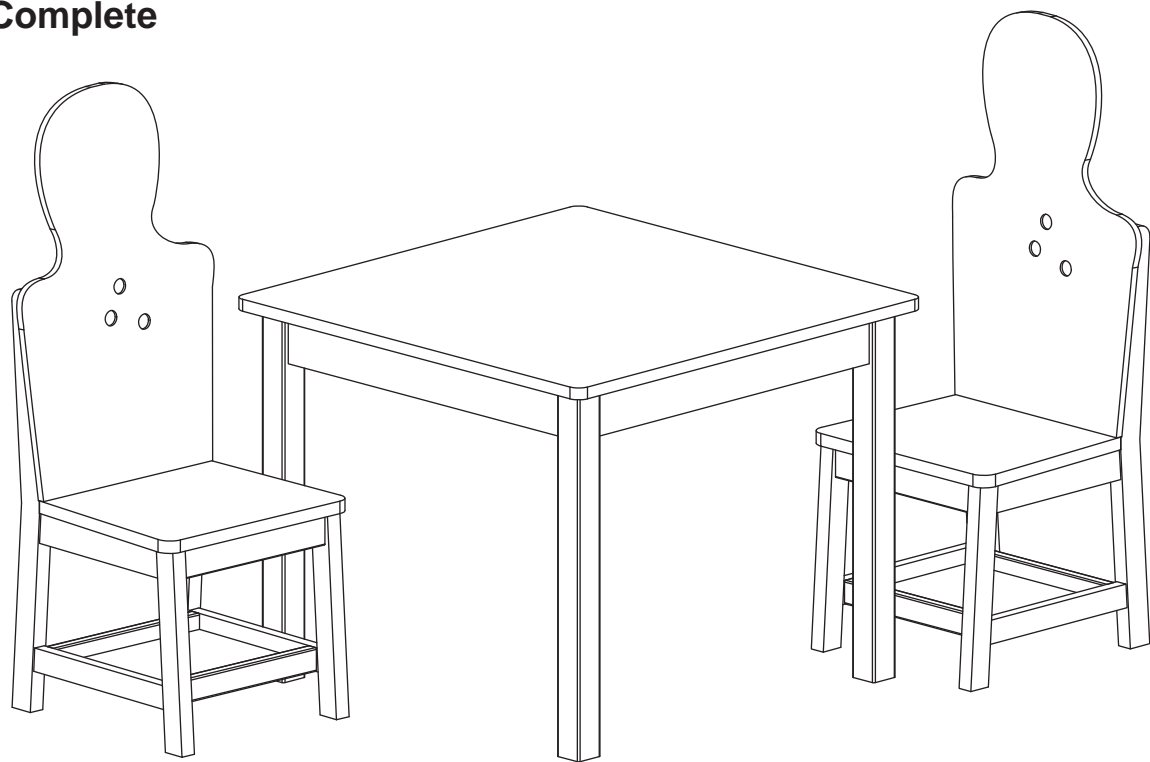

Dresses (part 10-13) can be attached to the chair back with hook and loop material.

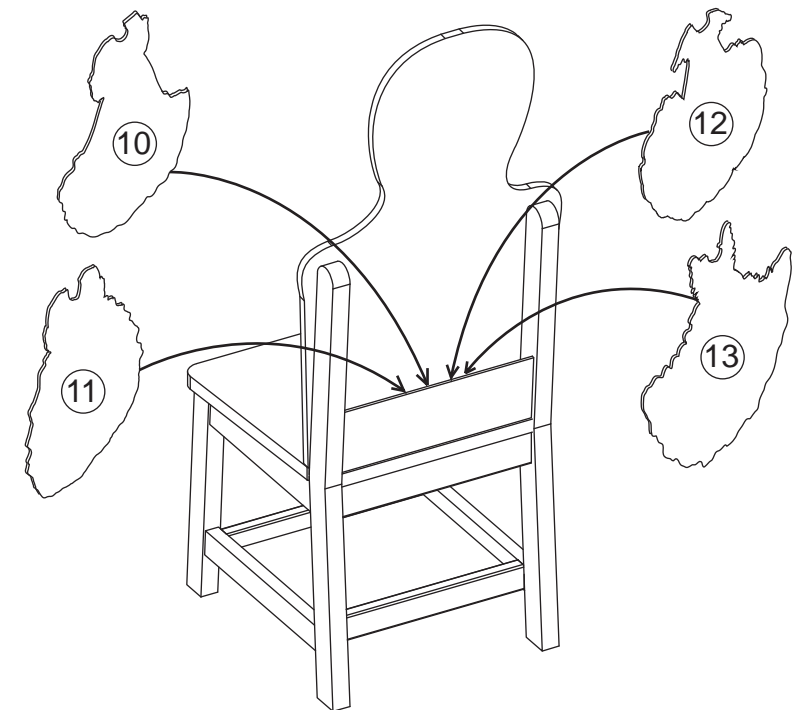

Use the pocket on the back of each chair for easy storage of the dresses when they are not in use.

Before calling customer service, please locate the batch code number (example: 105906/65006/04) found on the bottom or back of your product.

**Customer Service**  
1-800-933-0771  
[www.kidkraft.com](http://www.kidkraft.com)



Warning: This is intended for children of a specific age or above. Keep children younger than the specified age from using this item. Do not let children of any age climb on or around this item. Adult supervision is always recommended.

## **IMPORTANT INFORMATION - PLEASE READ FIRST**

ALL OF OUR WOODEN ITEMS ARE HANDCRAFTED, HAND ASSEMBLED, AND HAND PAINTED. EACH ONE IS UNIQUE. SLIGHT IMPERFECTIONS MAY OCCUR AND ARE NOT MANUFACTURING DEFECTS.

PLEASE NOTE THAT WE DO NOT WARRANTY AGAINST THE USE OF PERMANENT MARKERS, NON-WATER-BASED PAINTS, CRAYONS, OR WASHABLE MARKERS. SOME OF THESE ITEMS CONTAIN PERMANENT COLOR DYES THAT COULD DAMAGE THE SURFACE.

## **CLEANING INSTRUCTIONS**

CLEAN THE SURFACE USING A SLIGHTLY DAMP CLOTH AND MILD DISH WASHING LIQUID IF NECESSARY. DO NOT USE ANY CLEANING PRODUCT CONTAINING ALCOHOL OR AMMONIA. THESE WILL DULL THE SHINY SURFACE OF THE PRODUCT. FURNITURE POLISH WILL ALSO WORK TO CLEAN AND DUST OFF THE SURFACE.

WE RECOMMEND THAT YOU TEST ALL CLEANING MATERIALS ON THE UNDERSIDE OF ANY SURFACE THAT WOULD NOT BE SEEN DURING NORMAL USE OF THE PRODUCT. IF YOU HAVE QUESTIONS REGARDING THE MAINTENANCE OF THIS PRODUCT PLEASE FEEL FREE TO CALL US.

## **SOLE AND LIMITED WARRANTY**

THIS PRODUCT IS WARRANTED SOLELY AGAINST MANUFACTURING DEFECTS FOR A PERIOD OF 90 DAYS FROM THE DATE OF PURCHASE, WHICH RUNS ONLY TO THE ORIGINAL USER OF THE PRODUCT. IN THE EVENT OF A MANUFACTURING DEFECT, PARTS WILL BE REPLACED OR THE ENTIRE PRODUCT WILL BE REPLACED OR THE PURCHASE PRICE WILL BE REFUNDED, AT THE ELECTION OF THE MANUFACTURER. TO ACTIVATE AND PROTECT THIS WARRANTY, PRESERVE EVIDENCE OF ORIGINAL PURCHASE AND CAREFULLY INSPECT THE CONDITION OF THE PRODUCT PRIOR TO AND AFTER ASSEMBLY, LOOKING FOR MISSING, DEGRADED, BROKEN, IMPROPERLY SIZED OR HAZARDOUS PARTS, INCLUDING PARTS WHICH CAN BE SWALLOWED BY A CHILD, CAUSE A CHILD TO CHOKE, OR OTHERWISE CAUSE INJURY. SUCH PARTS MAY INCLUDE LOOSE SCREWS, EXPOSED NAILS OR SHARP EDGES. SHOULD YOU OBSERVE ANY DEFECTS, DO NOT USE THE PRODUCT AND IMMEDIATELY NOTIFY THE MANUFACTURER. FAILURE TO DO SO SHALL CONSTITUTE MISUSE. MISUSE, IMPROPER ASSEMBLY, FAILURE TO HONOR A WARNING, FAILURE TO SUPERVISE, INSPECT OR MAINTAIN THE PRODUCT, OR DAMAGE TO THE PRODUCT, WHETHER INTENTIONAL OR INADVERTENT, SHALL INVALIDATE THIS WARRANTY. THIS WARRANTY GIVES YOU SPECIFIC LEGAL RIGHTS, AND YOU MAY ALSO HAVE OTHER RIGHTS WHICH VARY FROM STATE TO STATE.

TO SUBMIT A WARRANTY CLAIM PLEASE CONTACT KIDKRAFT CUSTOMER SERVICE AT 1-800-933-0771 FOR INSTRUCTIONS ON HOW TO PROVIDE PROOF OF PURCHASE AND HOW TO RETURN THE ITEM FREIGHT PRE-PAID.

**CUSTOMER SERVICE 1-800-933-0771**

**[www.kidkraft.com](http://www.kidkraft.com)**