



## Mette 1193WK

- DE** Aufbau- und Gebrauchsanleitung für Art.-Nr. 1193WK  
**WICHTIG! DIE FOLGENDEN ANLEITUNGEN SIND SORGFÄLTIG ZU LESEN UND FÜR SPÄTERES NACHSCHLAGEN AUFZUBEWAHREN.**
- GB** Instructions for assembly and use for Art. No. 1193WK  
**IMPORTANT! READ THE FOLLOWING INSTRUCTIONS CAREFULLY AND RETAIN FOR FUTURE REFERENCE.**
- FR** Instructions de montage et d'emploi pour article n° 1193WK  
**IMPORTANT! LISEZ ATTENTIVEMENT LES CONSIGNES SUIVANTES ET CONSERVEZ-LES POUR POUVOIR VOUS Y REFERER ULTERIEUREMENT.**
- NL** Montage- en gebruiksaanwijzing voor art. nr. 1193WK  
**BELANGRIJK! DE VOLGENDE HANDLEIDINGEN DIENEN ZORGVULDIG GELEZEN TE WORDEN EN TE WORDEN BEWAARD VOOR LATERE RAADPLEGING.**
- IT** Istruzioni di montaggio e uso per l'art. n°. 1193WK  
**IMPORTANTE! LE SEGUENTI ISTRUZIONI DEVONO ESSERE LETTE ATTENTAMENTE E CONSERVATE PER CONSULTAZIONI SUCCESSIVE.**
- DK** Installations- og brugsanvisning for art.-nr. 1193WK  
**VIGTIGT! LÆS DE FØLGENDE ANVISNINGER GRUNDIGT OG OPBEVAR DEM TIL SENERE BRUG.**
- ES** Instrucciones de uso y de montaje para Art. -Núm. 1193WK  
**IMPORTANTE! LAS SIGUIENTES INSTRUCCIONES DEBEN LEERSE ATENTAMENTE Y GUARDARSE COMO FUTURA REFERENCIA.**
- HU** Összeszerelési és használati útmutató következő cikkszámhoz: 1193WK  
**FONTOS! ALAPOSAN OLVASSUK EL AZ ALÁBBI LEÍRÁSOKAT ÉS ŐRIZZÜK MEG ŐKET, HA KÉSŐBB UTÁNA AKARUNK NÉZNI VALAMINEK.**
- FI** Asennus- ja käyttöohje, art. nro 1193WK  
**TÄRKEÄÄ! LUE SEURAAVAT OHJEET HUOLELLISESTI JA SÄÄSTÄ NE MYÖHEMPÄÄ KÄYTTÖÄ VARTEN.**
- SI** Navodila za montažo in uporabo za arikel-št. 1193WK  
**VAŽNO! SKRBNO PREBERITE NASLEDNJA NAVODILA IN JIH SHRANITE ZA POZNEJŠO UPORABO.**

- HR** Upute za sastavljanje i uporabu artikla broj 1193WK  
**VAŽNO! SLJEDEĆE UPUTE PAŽLJIVO PROČITATI I SAČUVATI ZA KASNIJE.**
- NO** Monterings- og bruksveiledning for art. nr. 1193WK  
**VIKTIG! LES INSTRUKSJONEN NØYE OG OPPBEVAR DEN FOR SENERE REFERANSE.**
- PL** Instrukcja montażu i obsługi do nr art. 1193WK  
**WAŻNE! NALEŻY DOKŁADNIE PRZECZYTAĆ PONIŻSZE WSKAZÓWKI I ZACHOWAĆ JE, BY MÓC SKORZYSTAĆ Z NICH W PRZYSZŁOŚCI.**
- CZ** Návod na sestavení a používání pro výr. č. 1193WK  
**DŮLEŽITÉ! NÁSLEDUJÍCÍ INSTRUKCE SI POZORNĚ PŘEČTĚTE A USCHOVEJTE PRO POZDĚJŠÍ NAHLÉDNUTÍ.**
- PT** Instruções de montagem e uso para o art. n°1193WK  
**IMPORTANTE! AS SEGUINTEs INSTRUÇÕES TÊM DE SER LIDAS COM ATENÇÃO E GUARDADAS PARA REFERÊNCIA FUTURA.**
- TR** Ürün No. 1193WK için kurma ve kullanım talimatı  
**ÖNEMLİ! AŞAĞIDAKİ TALİMATLARIN İTİNALI BİR ŞEKİLDE OKUNMASI VE İLERİDE TEKRAR OKUNABİLMESİ İÇİN SAKLANMASI GEREKMEKTEDİR.**
- RU** Инструкции по сборке и использованию для артикула № 1193WK  
**ВАЖНО! НЕОБХОДИМО ВНИМАТЕЛЬНО ПРОЧИТАТЬ ПРИВЕДЕННЫЕ НИЖЕ ИНСТРУКЦИИ И СОХРАНИТЬ ИХ В НАДЕЖНОМ МЕСТЕ.**
- SK** Návod na montáž a použitie k prod. č.: 1193WK  
**DÔLEŽITÉ! NASLEDOVNÉ NÁVODY SA MAJÚ POZORNE PREČÍTAŤ A ODLOŽIŤ PRE NESKORŠIE NAHLIADNUTIE.**
- SE** Uppbyggnads- och bruksanvisning för art.nr. 1193WK  
**VIKTIGT! LÄS NOGGRANT FÖLJANDE ANVISNINGAR OCH SPARA DEM FÖR SENARE BRUK.**
- RS** Uputstvo za sastavljanje i primenu art. br. 1193WK  
**VAŽNO! SLEDEĆA UPUTSTVA PAŽLJIVO PROČITAJTE I SAČUVAJTE ZA KASNIJE.**
- JP** 組み立て・使用説明書 品番 1193WK  
**重要! 以下の取扱説明はよくお読みになり、今後の確認のために保管してください。**
- CN** 安装与使用说明 - 型号 1193WK  
**请注意! 请仔细阅读以下说明并留档备查。**
- KR** 제품-No. 의 조립 및 사용 설명서 1193WK  
**중요사항! 다음의 사용설명서를 꼼꼼히 읽고, 나중에 위해 잘 보관하십시오.**

Teileliste  
List of parts as illustrated  
Liste de pièces comme  
illustrée Onderdelenlijst  
Listino pezzi  
Indhold  
Lista de piezas  
Alkotóelemek jegyzéke  
Osaluettelo

Seznam elementov  
Popis dijelova  
Delliste  
Wykaz części  
Seznam součástí  
Lista de peças  
Parça listesi  
Перечень деталей  
Zoznam súčiastok

Artikellista  
Spisak delova  
パーツリスト  
零部表  
부품 목록

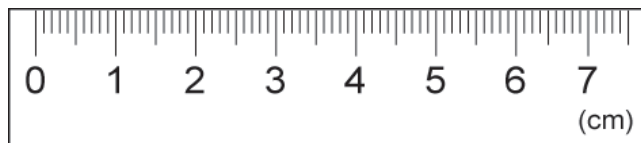
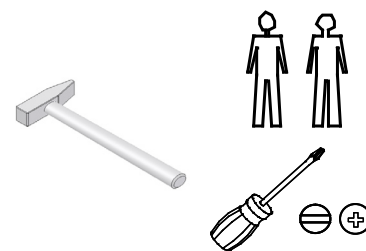

<p><b>A</b></p> <p><b>1 x</b> Art. Nr. X011101415</p>	<p><b>B</b></p> <p><b>1 x</b> Art. Nr. X011101416</p>	<p><b>C</b></p> <p><b>1 x</b> Art. Nr. X011101417</p>	<p><b>D</b></p> <p><b>1 x</b> Art. Nr. X011101418</p>	<p><b>F</b></p> <p>481 x 80 mm <b>1 x</b> Art. Nr. X011101422</p>
			<p><b>E</b></p> <p><b>1 x</b> Art. Nr. X011101419</p>	<p><b>G</b></p> <p>672 x 80 mm <b>1 x</b> Art. Nr. X011101423</p>
<p><b>H</b></p> <p><b>1 x</b> Art. Nr. X011101420</p>	<p><b>I</b></p> <p><b>1 x</b> Art. Nr. X011101425</p>	<p><b>J</b></p> <p><b>1 x</b> Art. Nr. Y011300175</p>	<p><b>K</b></p> <p>478 x 56 mm <b>1 x</b> Art. Nr. Y011300176</p>	
<p><b>L</b></p> <p><b>2 x</b> Art. Nr. X011101424</p>	<p><b>M</b></p> <p><b>2 x</b> Art. Nr. Y011300173</p>			
			<p><b>N</b></p> <p>666 x 56 mm <b>2 x</b> Art. Nr. Y011300174</p>	
<p><b>O</b></p> <p><b>1 x</b> Art. Nr. X011700157</p>	<p><b>P</b></p> <p><b>1 x</b> Art. Nr. X011700158</p>	<p><b>Q</b></p> <p><b>1 x</b> Art. Nr. X011101421</p>	<p><b>S</b></p> <p><b>1 x</b> Art. Nr. Y012300137</p>	
		<p><b>R</b></p> <p><b>2 x</b> Art. Nr. Z011101565</p>	<p><b>T</b></p> <p><b>1 x</b> Art. Nr. Y012300102</p>	
<p><b>U</b></p> <p><b>2 x</b> Art. Nr. Y012300229</p>	<p><b>V</b></p> <p><b>2 x</b> Art. Nr. Y012300230</p>	<p><b>W</b></p> <p><b>2 x</b> Art. Nr. Y012300231</p>	<p><b>Art. Nr. 204500184</b> <b>2 x</b></p>	

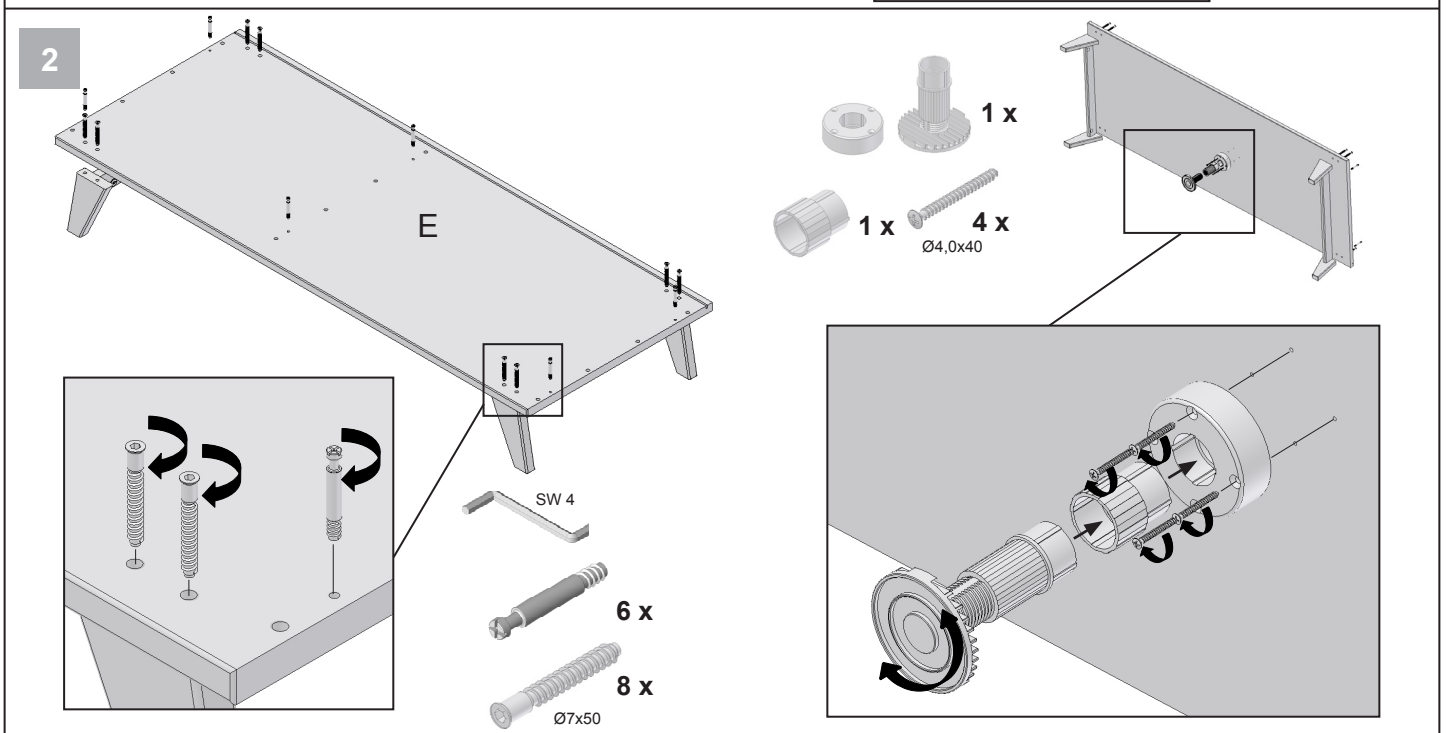
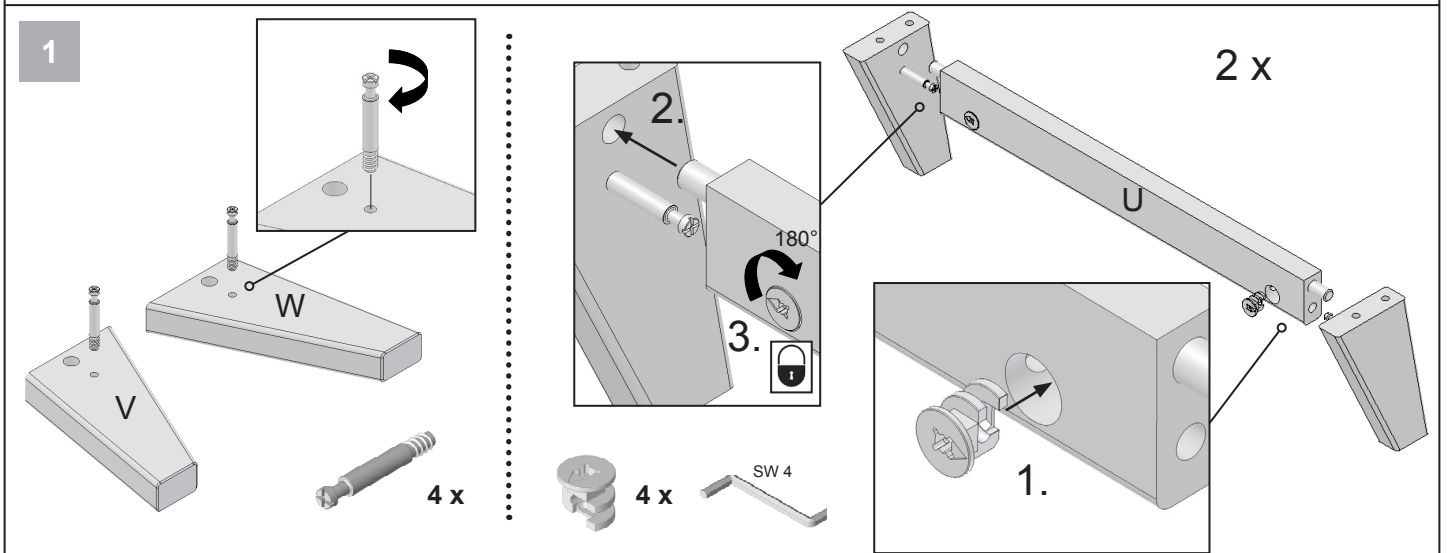
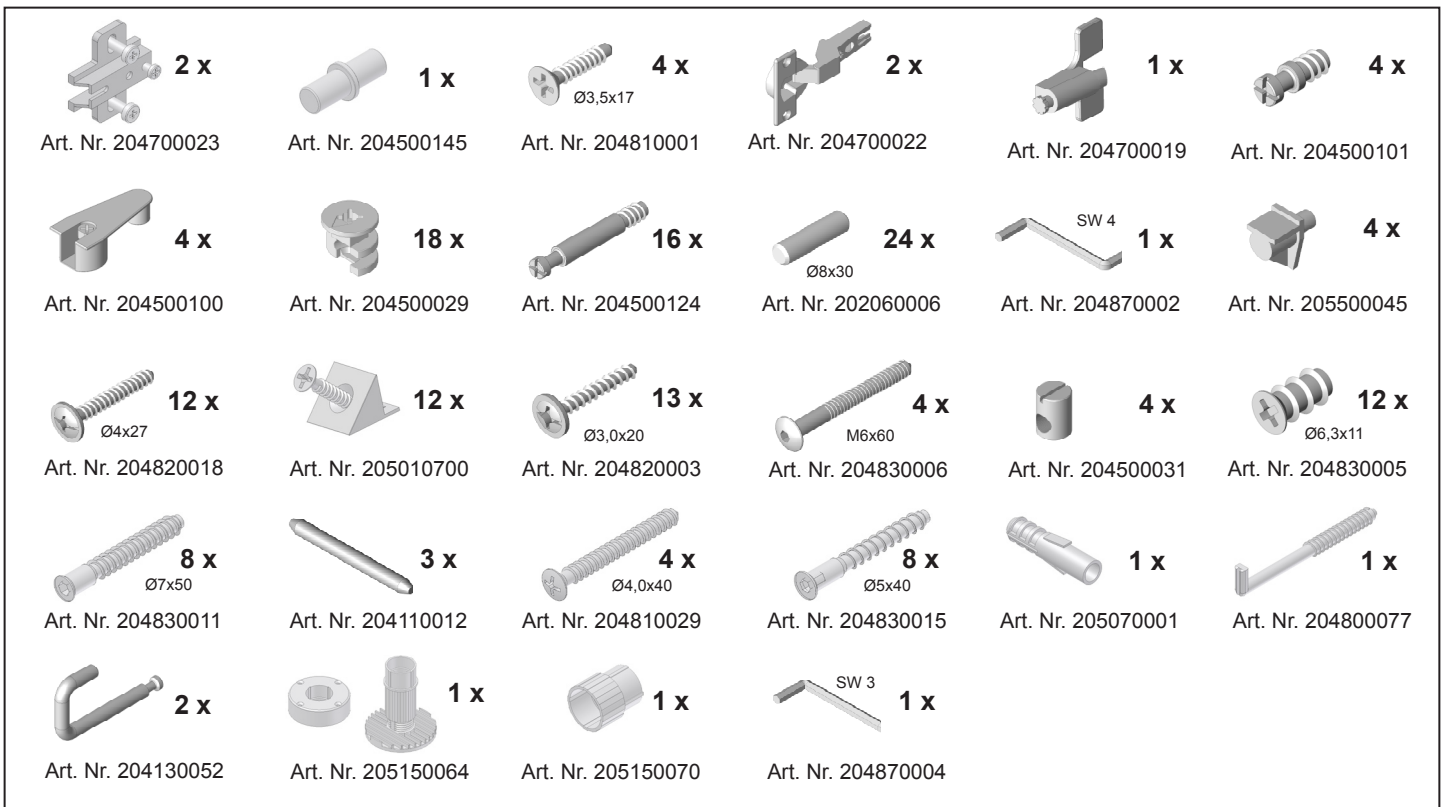

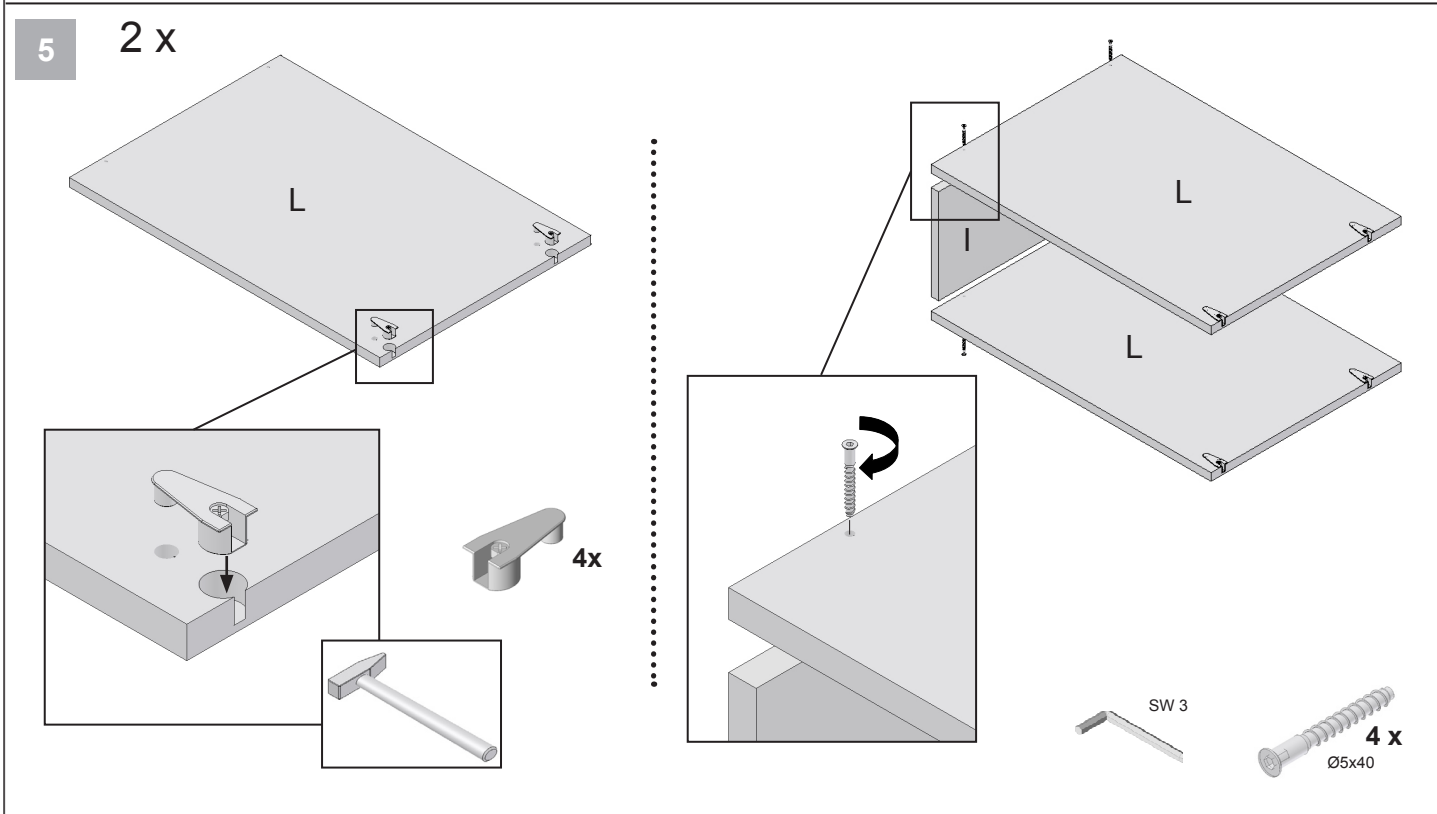
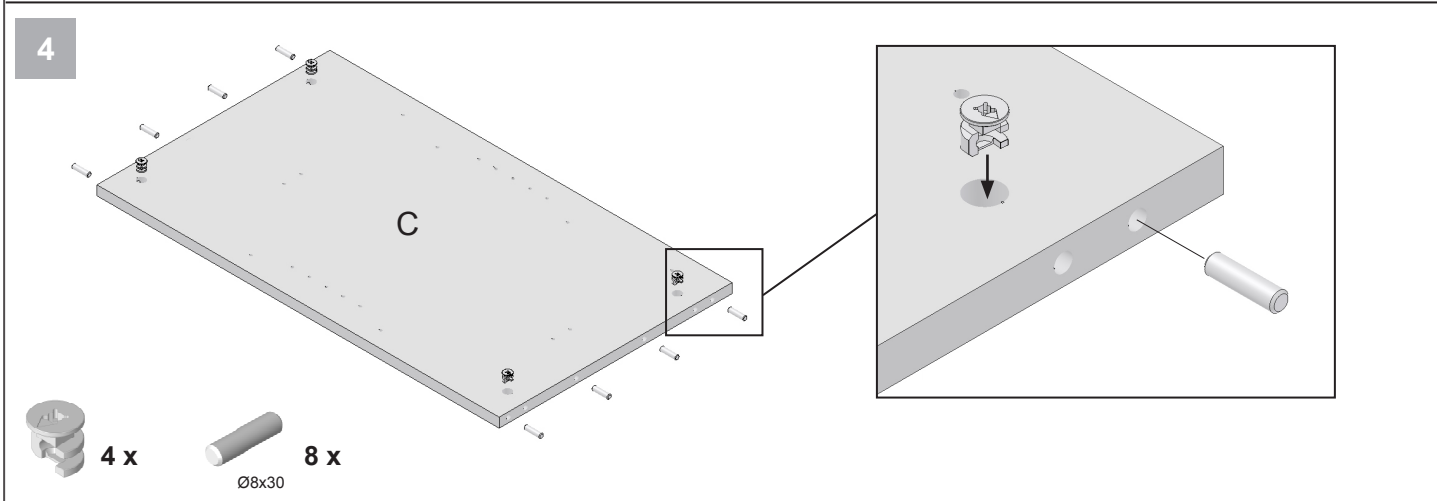
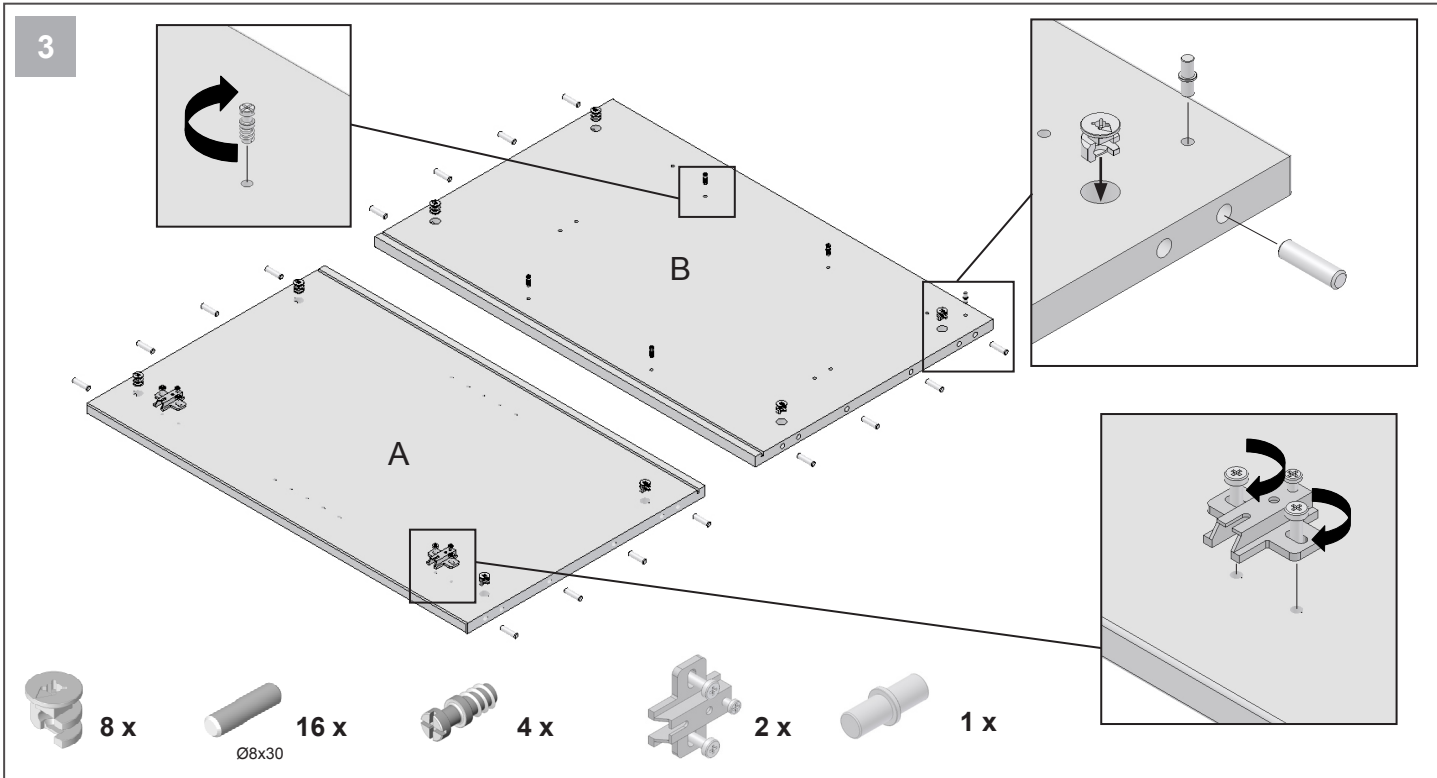

6

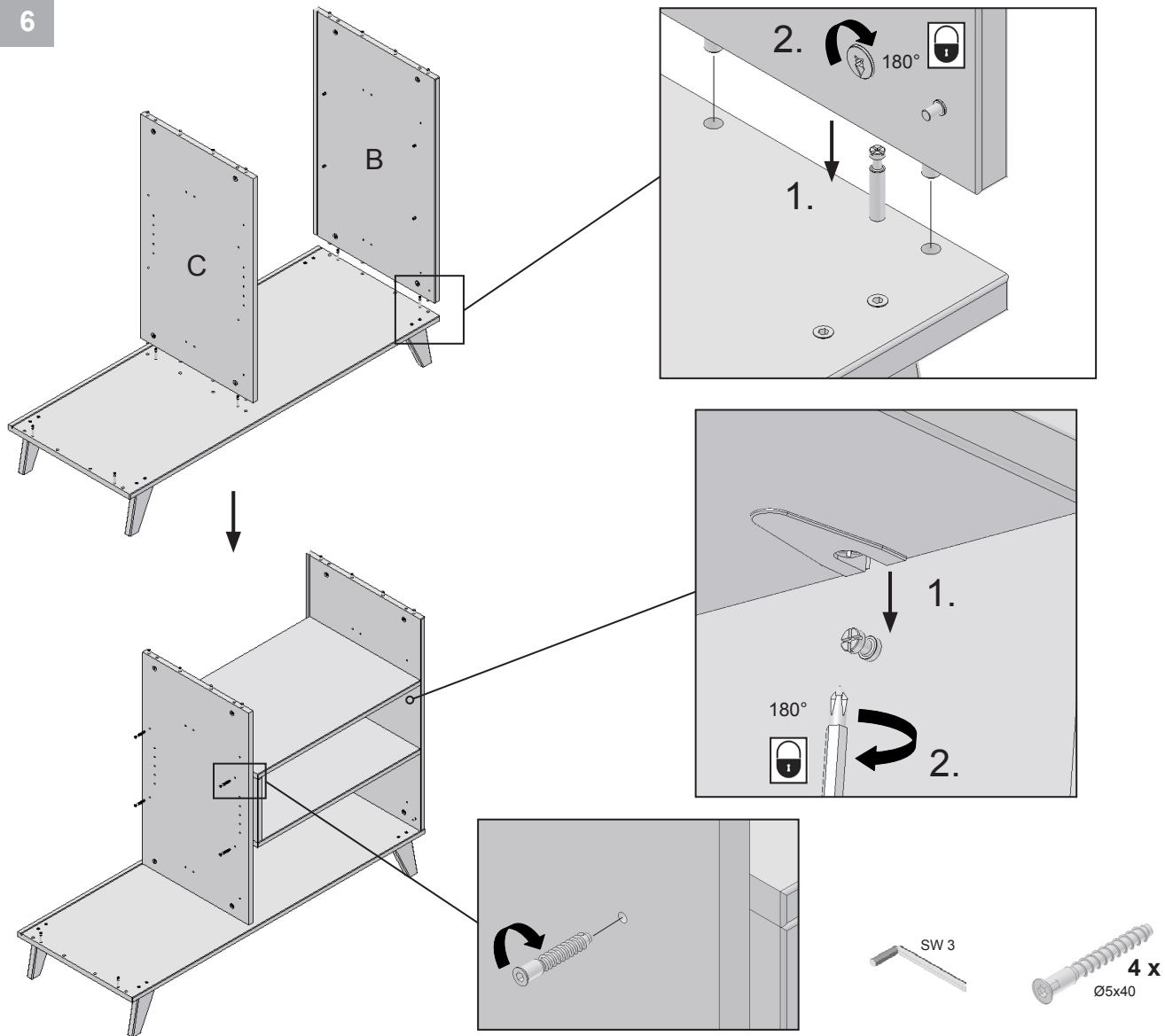

7

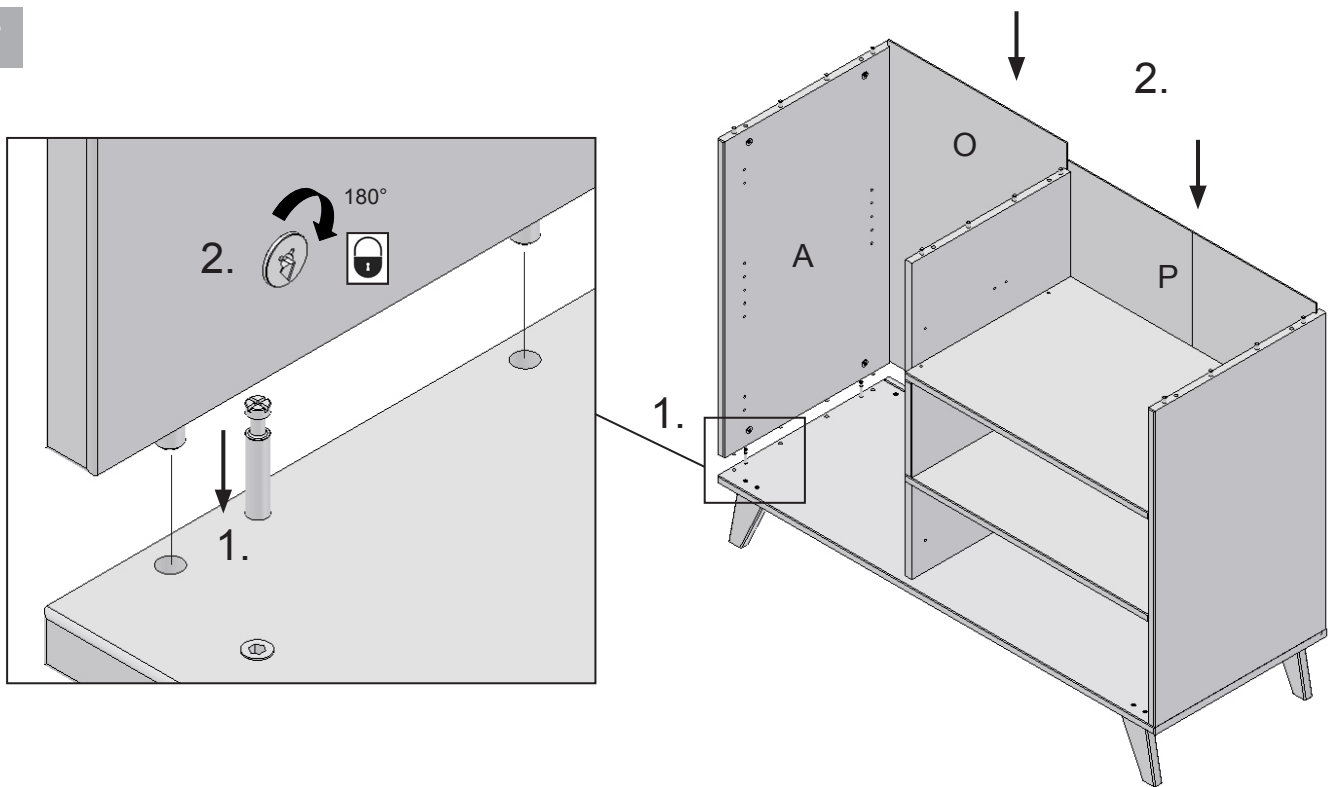

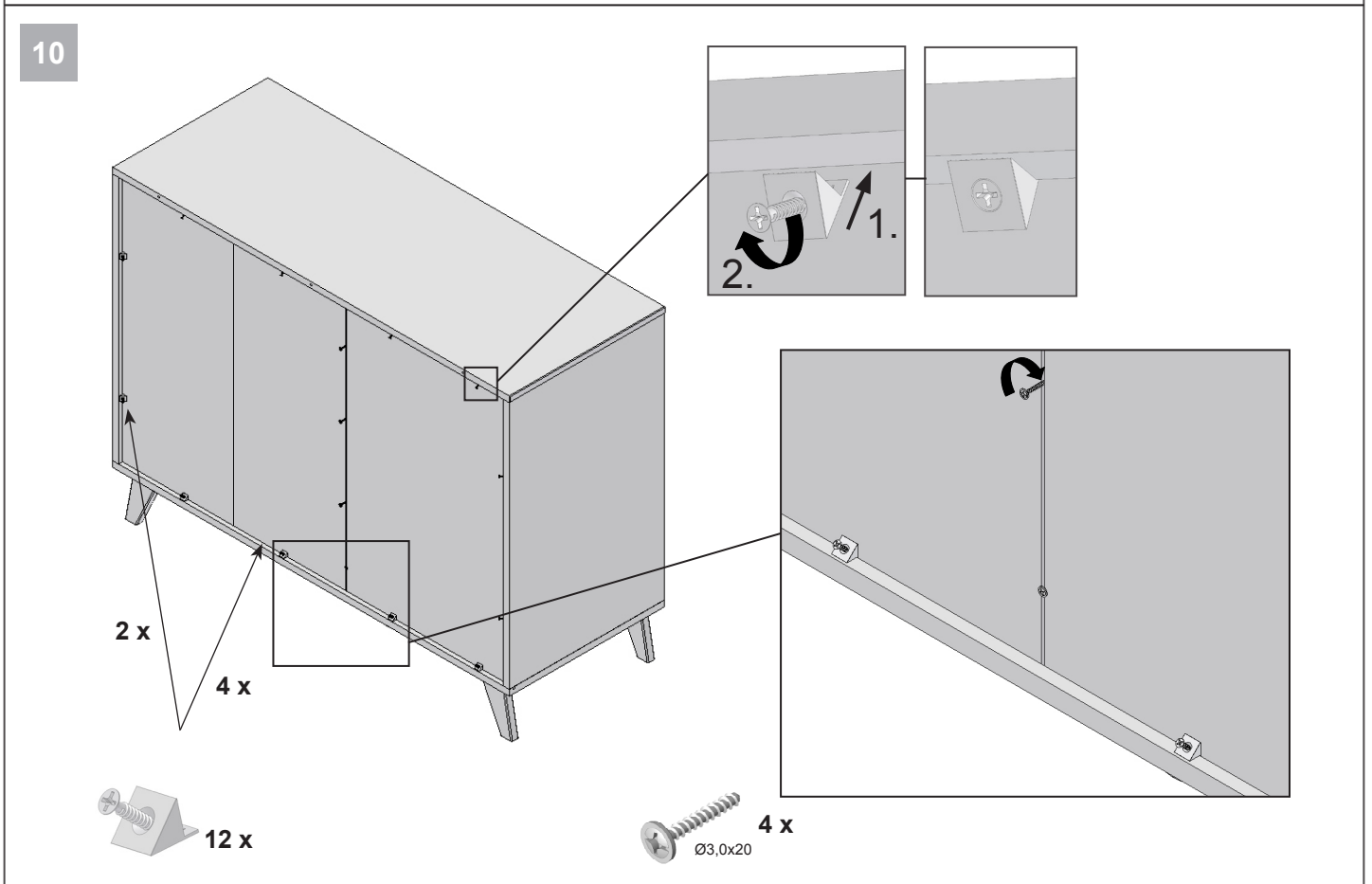
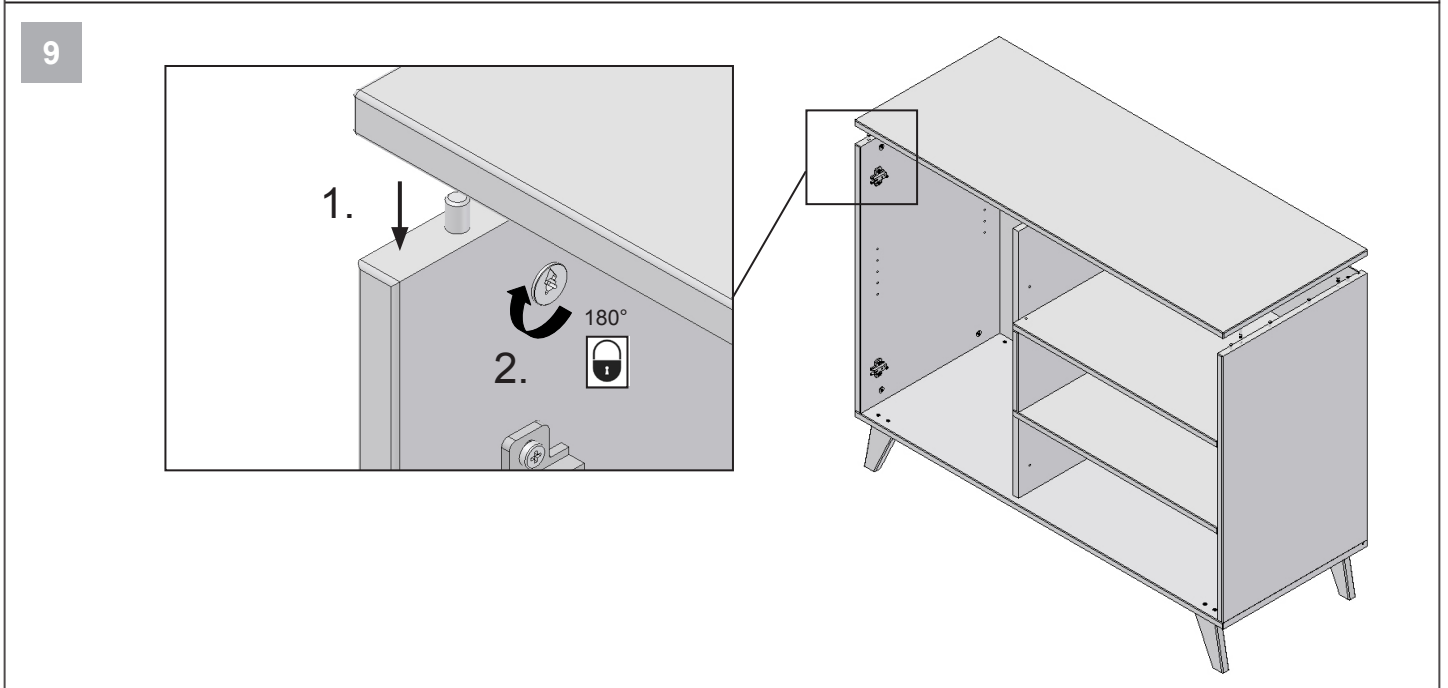
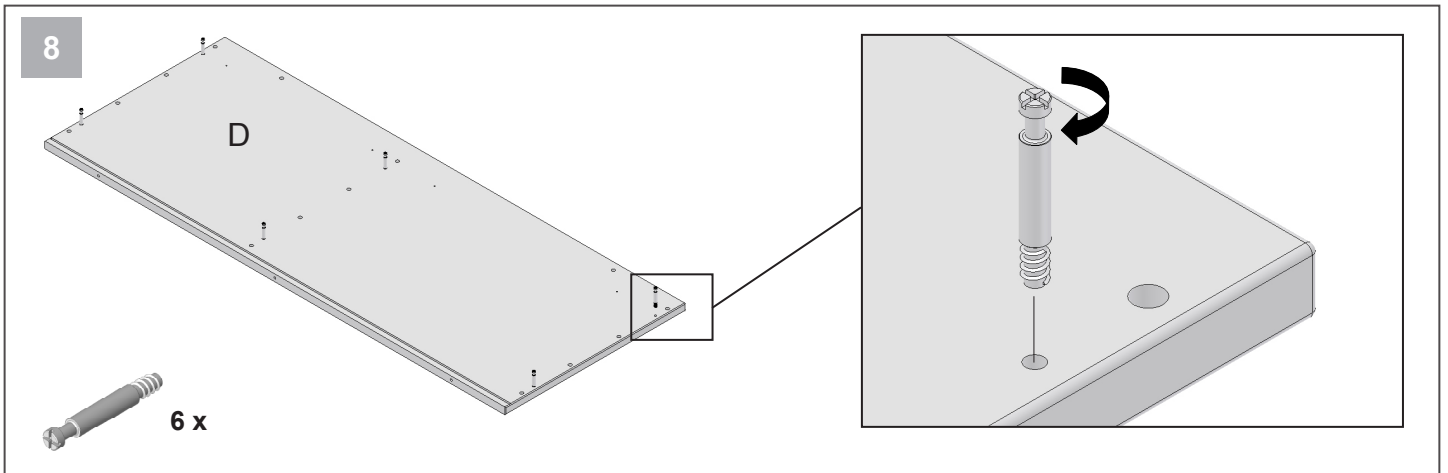

11

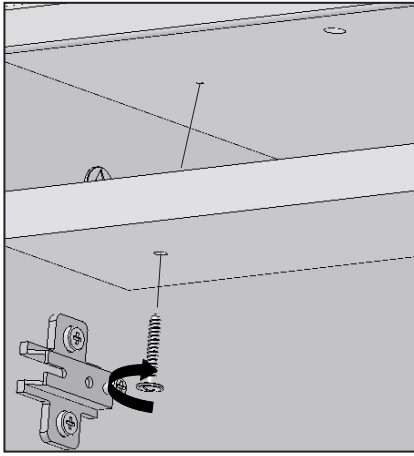

4 x  
Ø4x27

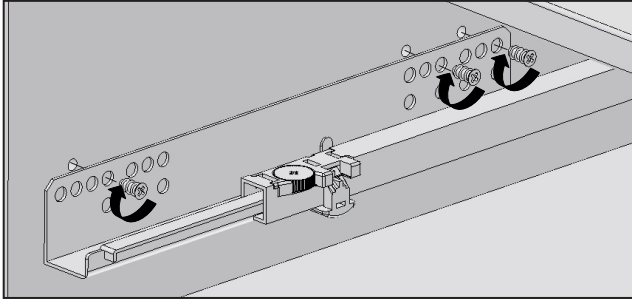
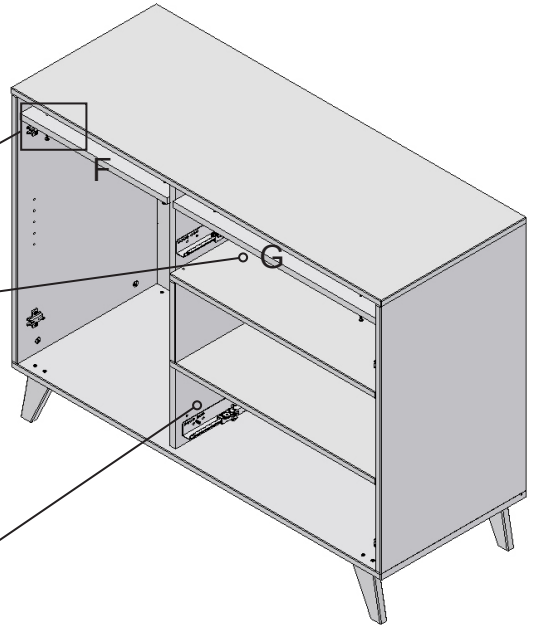

2 x  
2 x

12x

12

2 x

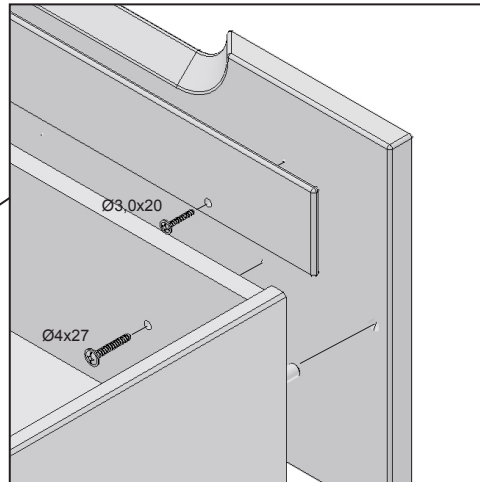
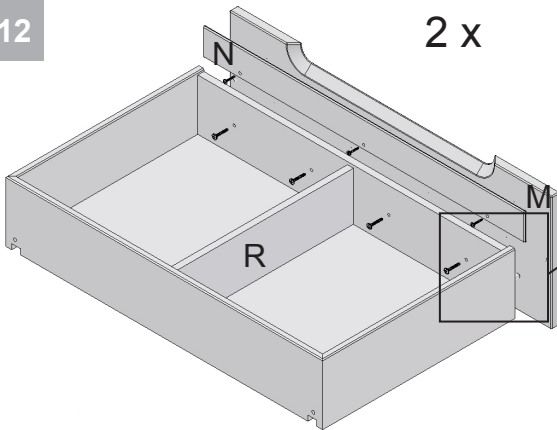

6 x  
Ø3,0x20

8 x  
Ø4x27

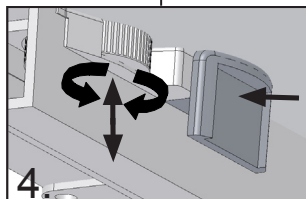
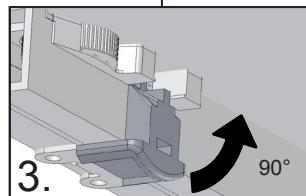
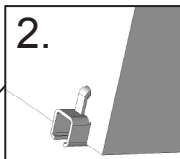
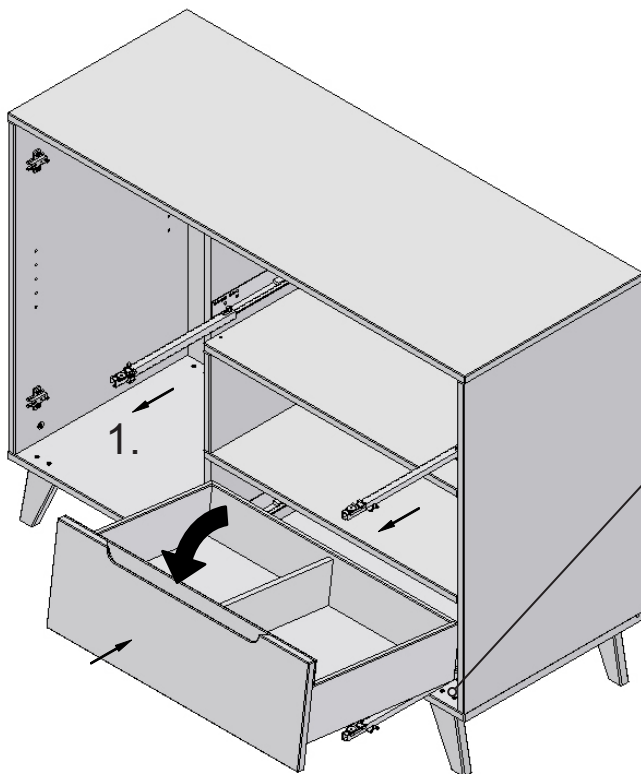



13

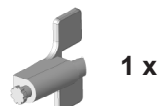
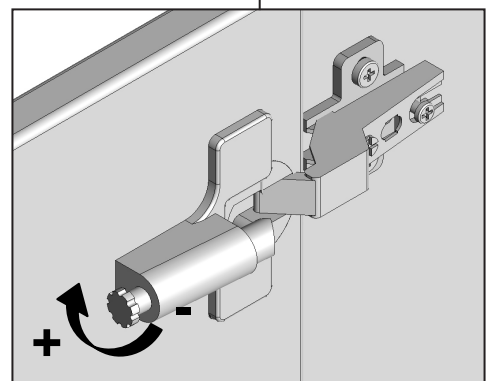
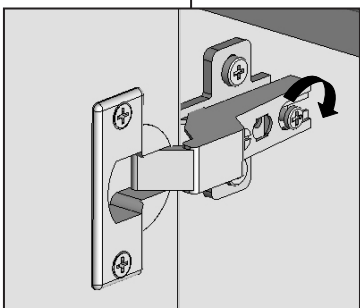
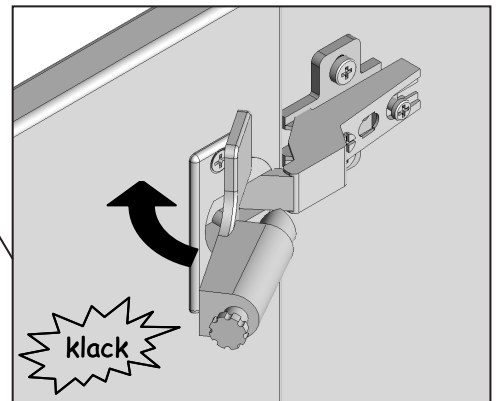
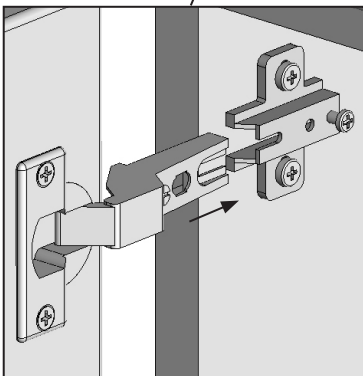
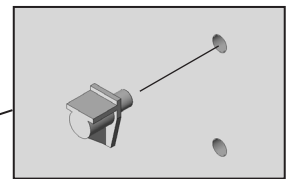
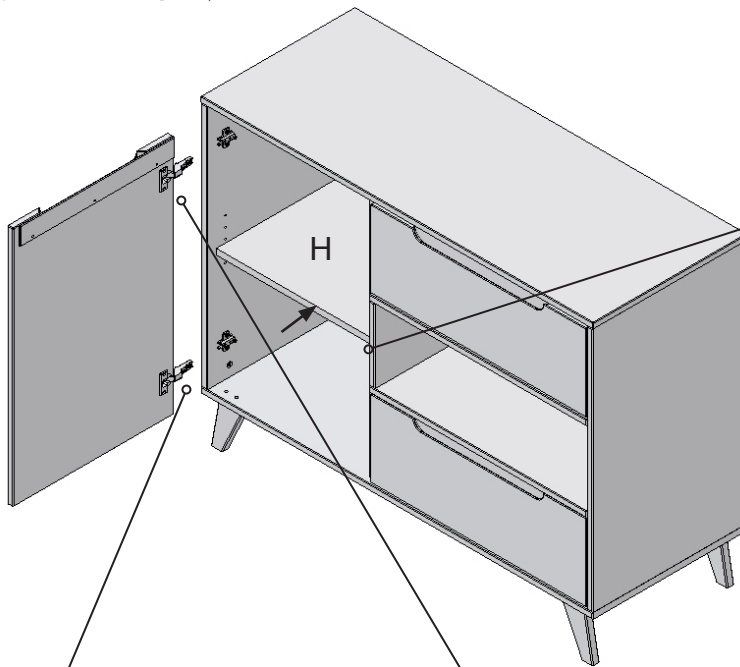
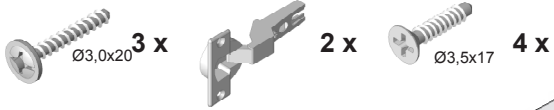
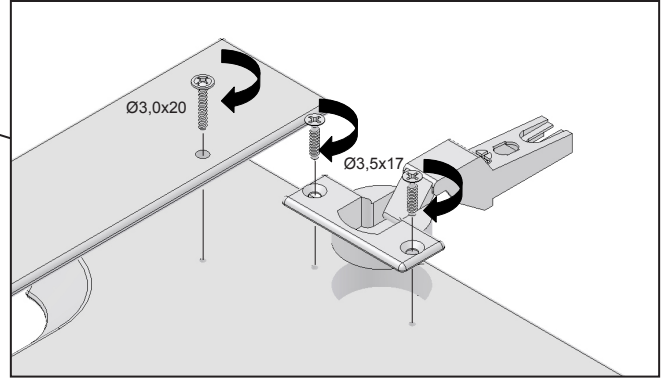
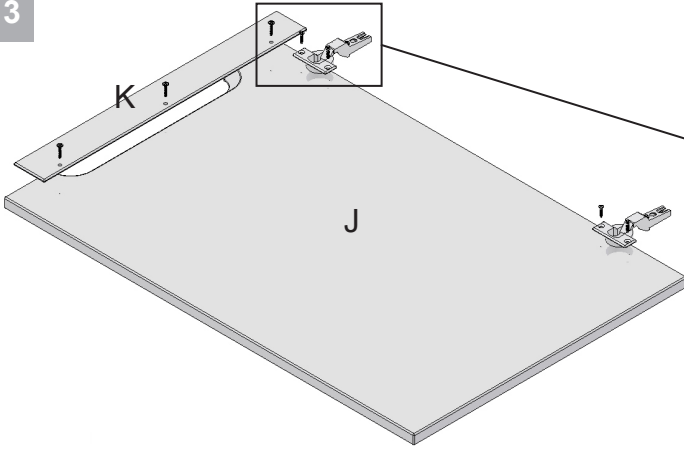

14

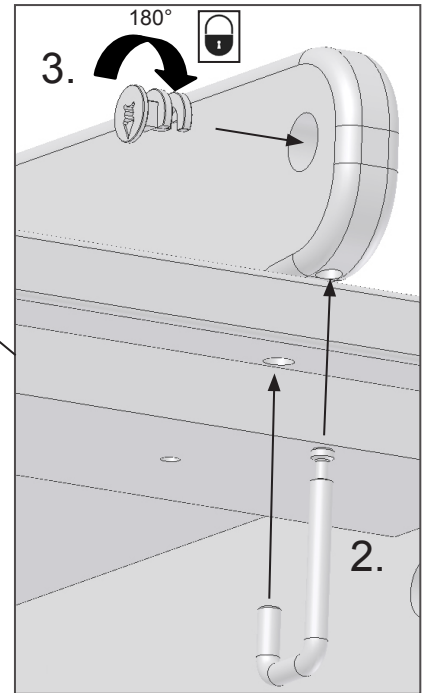
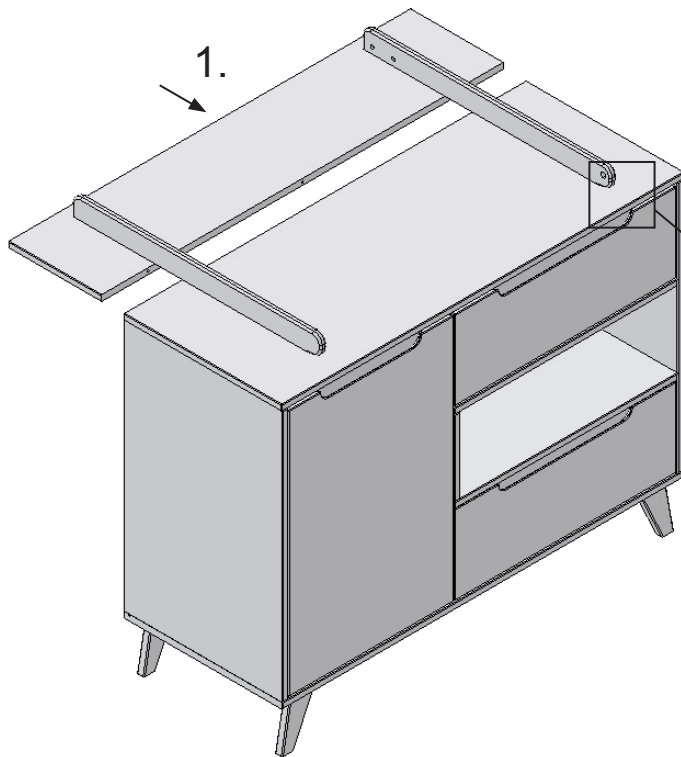
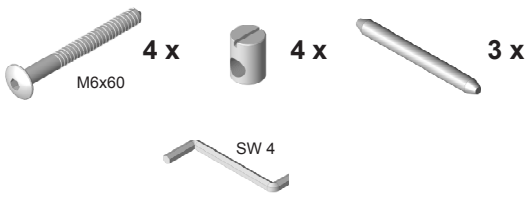
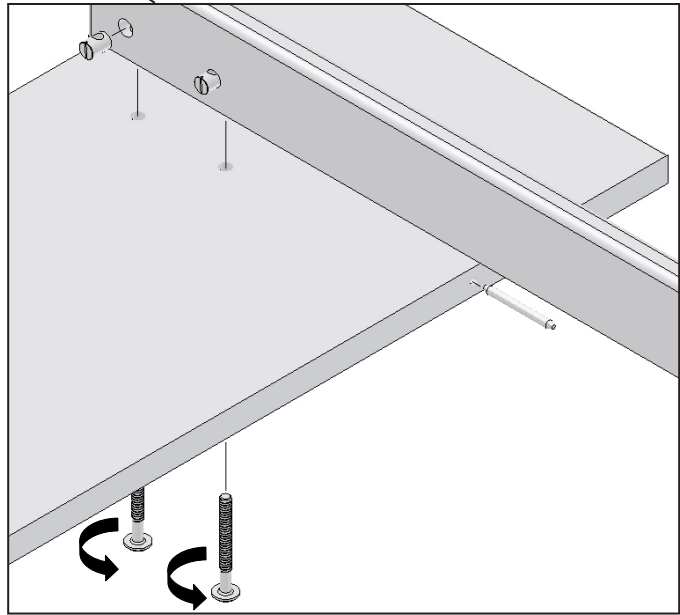
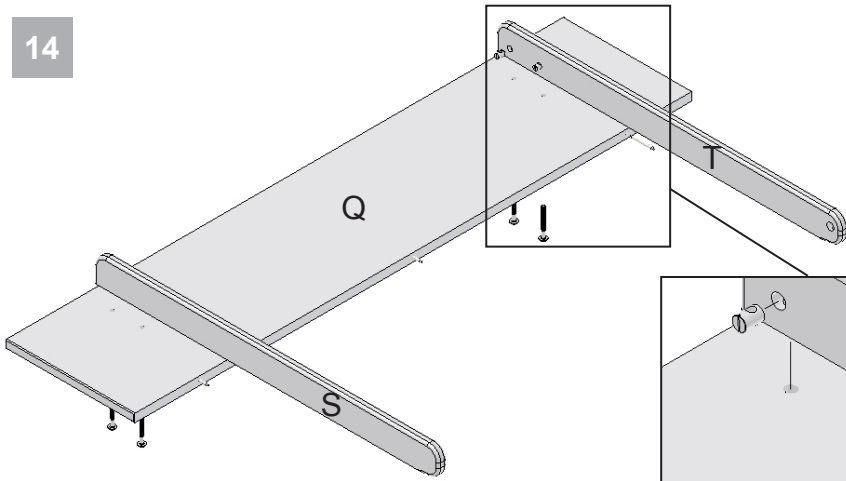

15

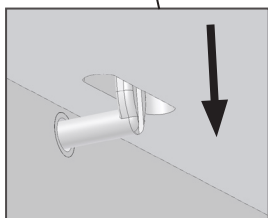
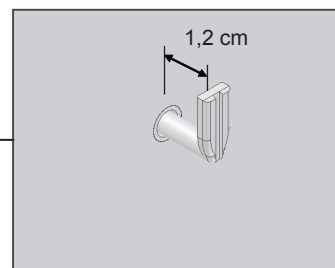
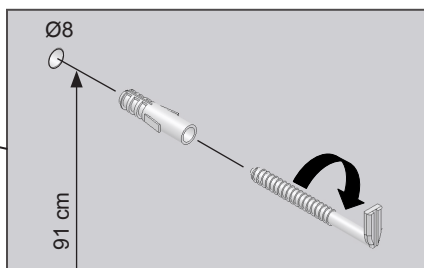
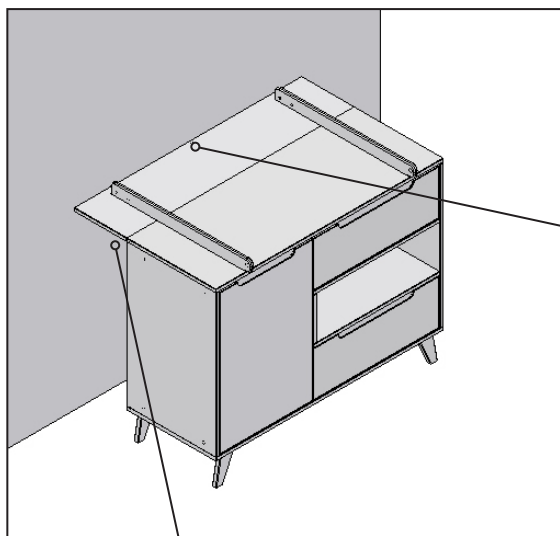

- (DE) Verwenden Sie als Wickelunterlage unsere Wickelmulde Art. Nr. 5835.
- (GB) We recommend to use our changing mats Art. No. 5835.
- (FR) Nous recommandons d'utiliser nos surfaces à langer en renforcement Art. no. 5835.
- (NL) Gebruik als aankleedkussen ons artikel 5835.
- (IT) Si raccomanda di utilizzare il nostro fasciatoio portatile morbido Art. n. 5835.
- (DK) Det anbefales at anvende en puslehynde som pusleunderlag, varenr. 5835.
- (ES) Para la comodidad del bebé, utilice nuestra base acolchada nº art. 5835.
- (HU) Pelenkázó alátétként használja 5835 cikkszámú pelenkázó alátétünket.
- (FI) Käytä hoitoalustana tuotettamme art. nro 5835.
- (SI) Kot podlago za previjanje uporabite naš izdelek, art. št: 5835, previjalno koritce.
- (HR) Kao podlogu za previjanje koristite naš bazen za previjanje, broj artikla: 5835.
- (NO) Som underlag under stelling brukes vår stellepute Art. Nr: 5835.
- (PL) Prosimy o stosowanie naszych korytek nr art. 5835 jako pomoc przy przewijaniu.
- (CZ) Jako podložku pro přebalování používejte naše přebalovací žlaby výř. č 5835.
- (PT) Utilize as nossas esteiras art. n° 5835.
- (TR) Kundaklama/bezleme altlığı olarak 5835 ürün numaralı kundaklama minderimizi kullanınız.
- (RU) В качестве подстилки для пеленания используйте наши лотки арт. № 5835.
- (SK) Ako prebaľovací podložku používajte náš produkt č. 5835.
- (SE) Som skötbord använder du vårt bord med art.nr. 5835.
- (RS) Za prepovijanje beba koristite našu podlogu br. art. 5835.
- (JP) オムツ交換の下敷きとして、当社のオムツ交換マットをお使いください。品番 5835.
- (CN) 请选择我们的尿布衬垫型号 5835.
- (KR) 지저귀 갈이대의 깔개로서 저희 제품의 지저귀 갈이대 매트 No. 를 사용해 주십시오. 5835.

