

Type \_\_\_\_\_  
 -80WB  
 P3210   
 P3223   
 P3236

Catalog No.	Finish Forged		Dimensions (Inches)			
	Black	Lamping	A	B	C	D
P3210	-80WB	2-60w G9 base halogen (included)	18	6	7-7/8	3
P3223	-80WB	3-60w G9 base halogen (included)	25	6	7-7/8	3
P3236	-80WB	4-60w G9 base halogen (included)	34-3/8	6-1/2	7-7/8	3

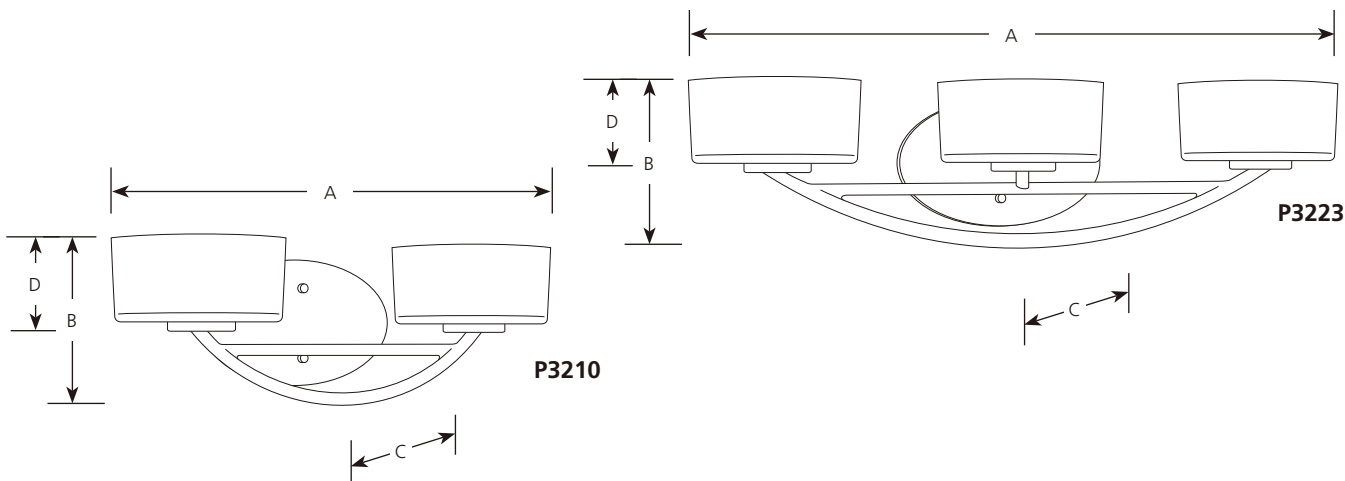

**Specifications:**

General

- Etched opal glass
- Clear glass lamp shield
- Hand painted forged black (-80WB) finish
- Steel construction
- Companion fixtures: Chandeliers, hall and foyer, wall bracket, close to ceiling, and additional bath and vanity

Mounting

- Wall mount
- Can be mounted in up or down position
- Canopy Covers a standard 4" octagonal recessed outlet box
- Mounting strap for outlet box included

Electrical

- Pre-wired
- G9 based sockets

Labeling

- cCSAus damp location listed