



Incandescent

**Dibs Outdoor**

**Outdoor**

Type \_\_\_\_\_

-09      -20

P5992           

Catalog No.	Finish		Lamping	Dimensions (Inches)			
	Brushed Nickel	Antique Bronze		A	B	C	D
P5992	-09	-20	1 (m) 100w	11-3/4	18	7-1/4	9

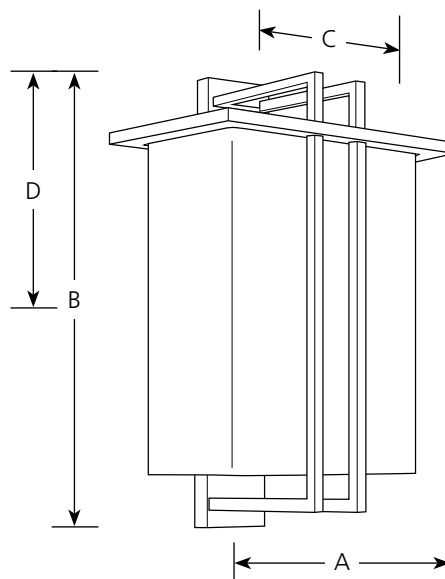

**Specifications:**

General

- Opal etched glass shade: 9-1/2" w., 13" ht., 5-9/16" deep
- Brushed Nickel -09 plated finish
- Antique Bronze -20 painted finish
- Steel construction
- Companion Bath and Vanity, Chain hung lantern, Close-to-ceiling, Hall and Foyer, Pendant, Post top lantern, Sconce, Wall bracket, Wall lantern, fixtures are available

Mounting

- Wall mount
- Back plate covers a standard 4" hexagonal recessed outlet box
- Mounting bracket for outlet box included

Electrical

- Medium base ceramic sockets
- Pre-wired

Labeling

- cCSAus Wet location listed

Progress Lighting  
 701 Millennium Blvd.  
 Greenville, South Carolina  
 29607

www.progresslighting.com

Rev. 03/13