

Type \_\_\_\_\_  
 -84 -91C  
 P3012    
 P3013

Catalog No.	Finish		Lamping	Dimensions (Inches)			
	Espresso	Biscay Crackle		A	B	C	D
P3012	-84	-91C	1 (m) 100w	7	11-1/2	9-1/2	4-1/2
P3013	-84	-91C	2 (m) 100w	17	10-1/2	9	5

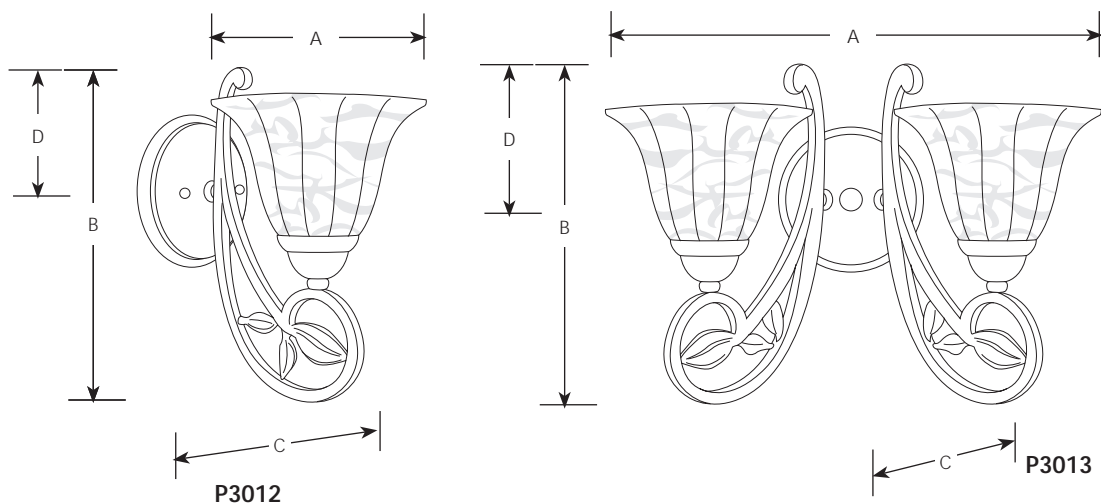

**Specifications:**

General

- Weathered sand stone glass shades
- Square arm tubing with leaf accents
- Hand painted finish
- Steel construction
- Companion fixtures: Chandeliers, hall and foyer, and close to ceiling

Mounting

- Wall mount
- Canopy Covers a standard 4" octagonal recessed outlet box
- Mounting strap for outlet box included

Electrical

- Pre-wired
- Medium based ceramic sockets
- Threaded socket ring to secure glass

Labeling

- UL-CUL "Damp Location" listed