

	Type				
	-09	-10	-15	-20	-33
P3190	<input type="checkbox"/>	<input type="checkbox"/>	<input type="checkbox"/>	<input type="checkbox"/>	<input type="checkbox"/>
P3191	<input type="checkbox"/>	<input type="checkbox"/>	<input type="checkbox"/>	<input type="checkbox"/>	<input type="checkbox"/>
P3192	<input type="checkbox"/>	<input type="checkbox"/>	<input type="checkbox"/>	<input type="checkbox"/>	<input type="checkbox"/>
P3193	<input type="checkbox"/>	<input type="checkbox"/>	<input type="checkbox"/>	<input type="checkbox"/>	<input type="checkbox"/>

Catalog No.	Finish					Lamping	Dimensions (Inches)			
	Brushed Nickel	Polished Brass	Polished Chrome	Antique Bronze	Cobblestone		A	B	C	D
P3190	-09	-10	-15	-20	-33	1 (m) 100w	6-1/2	7-1/2	9	3-1/2
P3191	-09	-10	-15	-20	-33	2 (m) 100w	17-1/4	8-1/8	7-3/8	5-3/4
P3192	-09	-10	-15	-20	-33	3 (m) 100w	24	8-1/8	7-3/8	5-3/4
P3193	-09	-10	-15	-20	-33	4 (m) 100w	33-1/4	8-1/8	7-3/8	5-3/4

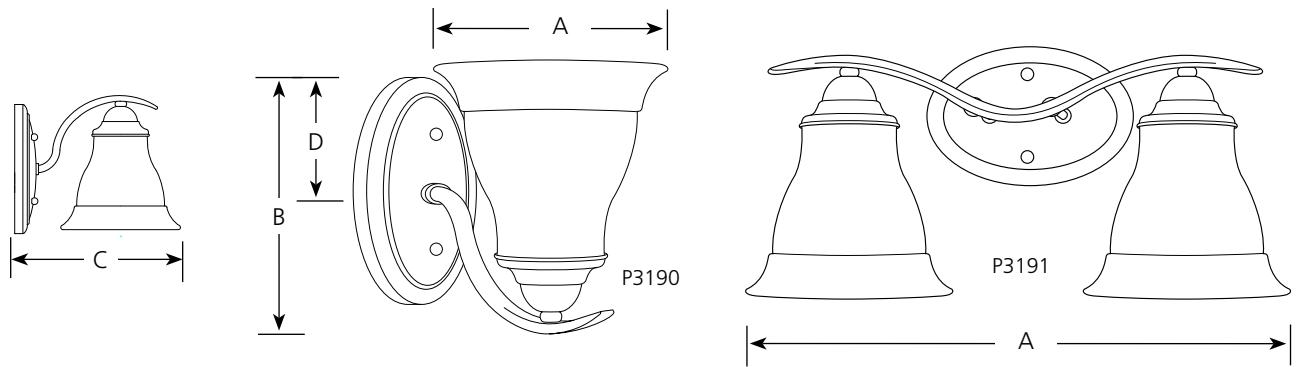

**Specifications:**

General

- Etched glass shades with slight banding, 6-1/2" dia. x 5-1/2" T, 1-5/8" dia. center hole
- Oval tubing with pinched ends
- Brushed Nickel (-09), Polished Brass (-10) and Polished Chrome (-15) finishes are plated
- Antique Bronze (-20) and Cobblestone (-33) are hand painted
- Steel construction
- Companion chandelier, hall and foyer, pendant, close to ceiling, and wall bracket units

Mounting

- Wall mounted
- Oval backplates
  - P3190: 4-3/4" W x 7-1/2" T x 1-1/8" deep
  - P3191, P3192, P3193: 4-3/4" W x 7" T x 1-1/8" deep
- Canopy covers a standard 4" hexagonal outlet box
- Mounting strap for outlet box included

Electrical

- Ceramic medium based sockets
- Pre-wired

Labeling

- UL-CUL damp location listed